

D. L. ADAMS.
Car-Coupling.

No. 160,635.

Patented March 9, 1875.

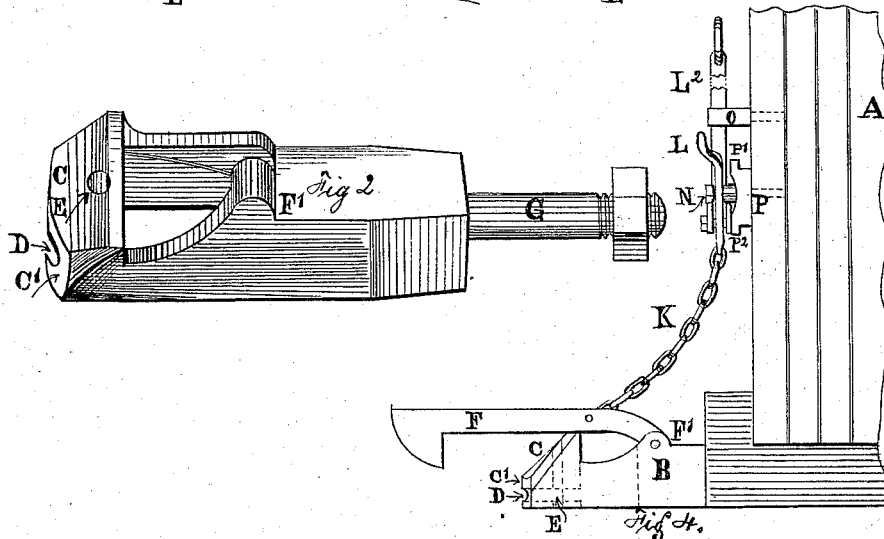
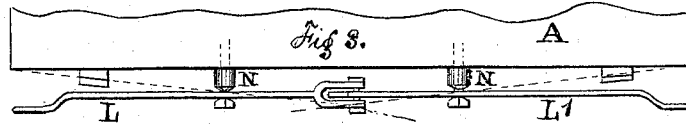
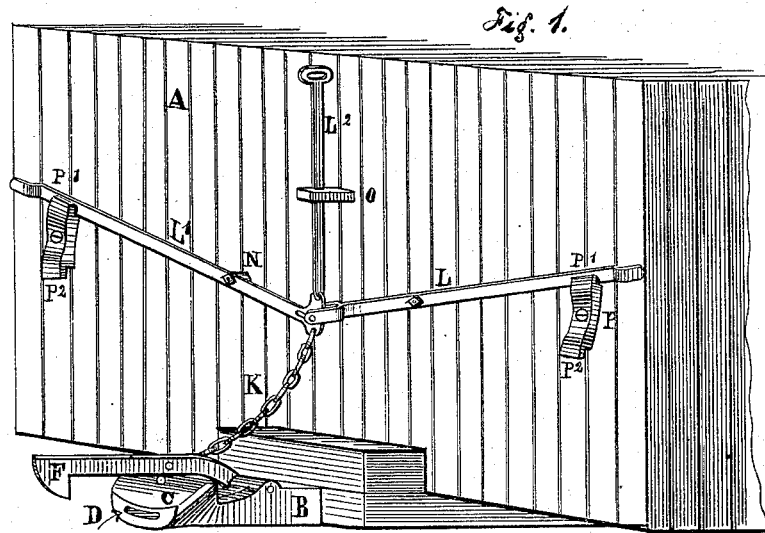

Witnesses:
John B. Edmonds
Thomas Edmonds

Inventor:
David L. Adams.
by Michael J. Stark
Attorney.

UNITED STATES PATENT OFFICE.

DAVID L. ADAMS, OF BUFFALO, NEW YORK.

IMPROVEMENT IN CAR-COUPINGS.

Specification forming part of Letters Patent No. 160,635, dated March 9, 1875; application filed August 8, 1874.

To all whom it may concern:

Be it known that I, DAVID L. ADAMS, of Buffalo, State of New York, have invented a Car-Coupling, of which the following is a specification:

My invention relates to that class of car-couplings that couple the cars automatically by means of pivoted hooks; and it consists in the construction of the draw-head, having the hook pivoted within lugs situated on the top of the draw-head, said hook swinging vertically to engage and disengage with a vertical catch-plate, having an inclined face, situated above the buffer surface, and extending transversely the entire width of the face of the draw-head, and projecting over the sides of the same, to insure the positive and unobstructed action of the hook; also, in providing the buffer-surface with an aperture for the reception of an ordinary link and the inclined catch-plate, with the pin-aperture passing vertically through the said draw-head and link-aperture; furthermore, in the arrangement of levers for operating the hook from either side of the car, in a manner hereinafter described.

In order to enable any one skilled in the art to which my invention appertains to make and use the same, I shall describe its construction and operation, having reference to the accompanying drawings, which make part of this specification and illustrate my invention more fully.

In the drawings, Figure 1 is a perspective view of my improved car-coupling as attached to a railroad-car. Fig. 2 is a perspective view of the draw-head; Fig. 3, a top view of the operating-levers $L L^1$, and Fig. 4 a side elevation of the coupling complete.

Like letters of reference indicate like parts in the several figures.

A is one of the ends of a railroad-car, to which my coupling is attached. B is the draw-head, constructed of suitable material. It consists of the inclined catch-plate C, having the aperture E for the admission of a coupling-pin, the buffer-surface C', with the aperture D for the reception of an ordinary link, the curved hook F, and the shank G. C is the catch-plate. Its front is an inclined surface, and its back a perpendicular wall. It is extending across and projecting over one or

both of the sides of the draw-head B sufficiently to present to the hook F a catch-plate of ample width to insure the proper coupling under all circumstances. One of the sides of the draw-head—that opposite the hook F—is diminished in width behind the perpendicular catch-surface, to allow the hook to fully engage with the same without obstruction. F is a slightly-curved coupling-hook. It is pivoted within lugs F' on the top of the draw-head B, and extends sufficiently over the draw-head to engage with the catch-plate of the opposite car, allowing also the necessary play. The hook F is pivoted within lugs on the top of the draw-head, to allow the use of a straight or only slightly-curved coupling-hook, in connection with the inclined catch-plate above the aperture for the ordinary link-coupling, which aperture should occupy the same place as those of the ordinary link-coupling, in order to engage my improved coupling with an old-style coupling whenever occasion requires. If this hook were pivoted within the sides of the draw-head, it would be required to be curved so much as to cause its liability to straighten from the tensile strain exerted upon the same when pulling the load. The hook F is operated by means of the chain K, attached with one end to the hook, and with the other end to the lever L, in a manner hereinafter to be described. G is the shank of the draw-head. It is attached to the car in the usual manner, and fits the draw-timbers of the same without any material alteration thereon. It is provided with the usual springs. $L L^1$ are two levers for operating the hook F. They have their fulcrums upon the studs N, fastened to the face of the car. L^1 is provided with a slot-hole near its end, and with two lugs—the lower one for attaching the chain K, and the upper one for connecting with the hand-rod L^2 . Lever L is provided on its extremity with a fork, and connects with the lever L^1 by a pin passing through the same. The levers $L L^1$ fit the studs loosely, so that they will allow a horizontal and vertical motion of the same, and can be operated from either side of the car, so that whenever one of the levers L is operated the opposite lever will perform the same motion. L^2 is a hand-rod attached to the lever L^1 , and passing through a socket, O, said

socket O being the fulcrum for the hand-rod L². The three levers L, L¹, and L², being connected with each other, operate simultaneously whenever one is actuated. P are two stops, attached one on each side of the face of the car. They are for the purpose of keeping the levers L and L¹ in their proper places. Each of these stops is provided with two hooks or catches, P¹ and P², sufficiently distant from the face of the car to allow the levers L L¹ to be placed behind the same.

It will be observed that the catch-plate C is projecting over the sides of the draw-head. By constructing this catch-plate this wise I am enabled to reduce the width of the draw-head so much that it will fit the draw-timbers of any car furnished with the old-style link-and-pin coupling without material, if any, alteration thereon, thus greatly reducing the cost of my draw-head and of fitting the same to an old car. The catch-plate C is situated above the buffer-surface C', provided with the aperture D for the reception of the ordinary coupling-link, and is of such a width as to insure the proper connection of the cars under the most unfavorable circumstances—as, for instance, when the cars have to be coupled when upon a curve, or when they are of different gage, &c.—one of the side plates of the draw-head being diminished in width behind the perpendicular catch-surface to allow the unobstructed action of the hook F of the opposite car.

The operation of the coupling, and also of the uncoupling, device is as follows: Supposing a train of cars to be uncoupled, and the coupling-hooks F in the position as shown in the drawings, in order to uncouple hold is taken of one of the levers L L¹, which, being connected to each other, work simultaneously, and can be operated from the sides of the cars without stepping between the same, and the lever L lifted out of the catch P¹, and, after being swung horizontally to clear the catch P¹, depressed and engaged with the catch P². This will have the effect of lifting the hook F out of contact with the catch-plate C of the opposite car, and also of placing the opposite lever in the same position as that operated upon. If it is desirable to uncouple the cars from the top of the same, the hand-rod L² is actuated to make the levers L L¹ perform the operation described, the socket O acting thereby as a fulcrum to swing the levers L L¹ horizontally to disengage with the catches P¹ and engage the same with the catches P², or vice versa.

To engage a set of cars it is merely necessary to remove the lever L from the catch P², when the hook F will drop into a horizontal position, so that when the two cars are pushed together the hooks F will travel up the inclined surface of the catch-plate C, and, after having passed the upper, drop back into the position first occupied, thus coupling automatically. The buffer-surface C' arrests the momentum of the cars when pushed together, in connection with springs placed behind the shank of the draw-head B.

Should two cars have to be coupled, one of which has my improved hook-coupling and the other the ordinary link and pin, the coupling will be accomplished by means of the link entering the aperture D, in connection with a pin passing through the pin-hole E.

The hooks F are pivoted within lugs F', situated on the top of the draw-head B, and are slightly curved. By extending the lugs F' sufficiently above the top of the draw-head a straight hook may be substituted.

Having thus fully described my invention, I desire to secure to me by Letters Patent—

1. The draw-head B, having the horizontal link-aperture D within, and the inclined catch-plate C, with the pin-hole E, above the buffer-surface C', the inclined catch-plate extending transversely across, and projecting over, the sides of the draw-head B, (one of the same being reduced in width below the apex of the inclined catch-plate C,) and engaging with the hook F, pivoted within lugs F' on the top of the draw-head B, all combined substantially in the manner and for the purpose set forth.

2. The combination, with the levers L L¹, supported upon studs N, with capability of vertical and horizontal movement, and the rod L², also capable of horizontal and vertical motion, of the stops P, provided with catches P¹, all constructed to operate substantially as and for the purpose described.

3. The draw-head B, with the inclined catch-plate or shoulder C on a level with or projecting above, and extending transversely across and projecting over, one or both of the side plates or walls of the draw-head B, and having lugs F', for supporting the pivot of the hook F, formed above the draw-head B, substantially as and for the purpose described.

DAVID L. ADAMS.

Witnesses:

MICHAEL J. STARK,
W. P. TAYLOR.