

T. Mac NEIL.

Chambers of Fire Arms and Ordnance.

No. 160,691.

Patented March 9, 1875.

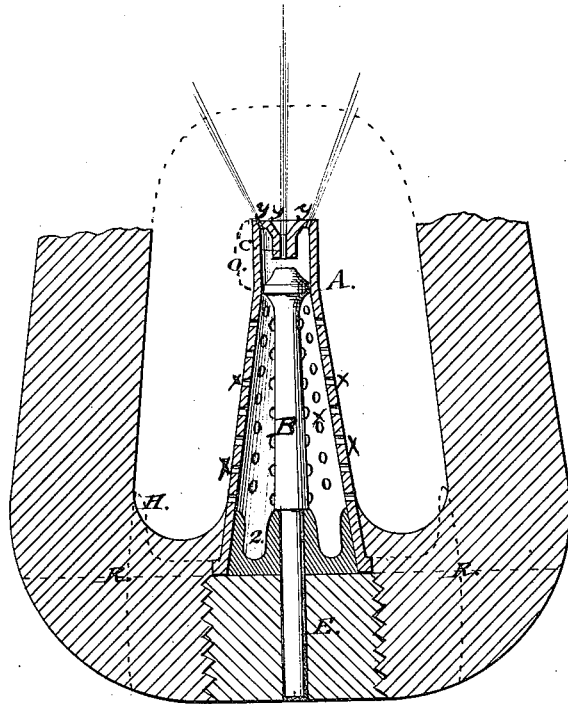

Witnesses:

Geo. J. Heron
William Deplitch

Inventor:

Thomas Mac Neil

UNITED STATES PATENT OFFICE.

THOMAS MAC NEIL, OF BROOKLYN, NEW YORK.

IMPROVEMENT IN CHAMBERS OF FIRE-ARMS AND ORDNANCE.

Specification forming part of Letters Patent No. **160,691**, dated March 9, 1875; application filed February 6, 1875.

To all whom it may concern:

Be it known that I, THOMAS MAC NEIL, of Brooklyn, in the county of Kings and State of New York, have invented certain new and useful Improvements in the Powder-Chambers of Ordnance; and I do hereby declare the following to be a full and clear description thereof, reference being had to the accompanying drawing and to the letters of reference marked thereon.

My invention relates to all classes of ordnance, or other devices for discharging projectiles; and it has for its object to increase the explosive force of the powder, and thereby to accelerate the projectile force and lessen the recoil. And to this end the nature of my invention consists in a perforated air-chamber, placed within the powder-chamber, and so arranged with a firing-pin, or other firing device, as to explode the fulminate at the inner end of the air-chamber, and ignite that portion of the charge first which is located between the end of the air-chamber and the projectile, all as hereinafter more fully set forth.

In order to enable others skilled in the art to which my invention appertains to make and use the same, I will now proceed to describe its construction and operation, referring to the annexed drawing, which forms a part of this specification, and which fully illustrates my invention.

R represents the breech of a gun of any desired construction, which may or may not be provided with the breech-plug E. A represents a conical air-chamber secured in any suitable manner within the powder-chamber H to the breech R. This air-chamber is provided with perforations X, extending from its base to a point, O, a suitable distance from its inner end. These perforations must be small enough to prevent the powder entering the air-chamber, and yet their combined area be sufficient to allow of the free and easy compression and expansion of the air and gases.

In the extreme inner end of the air-chamber are one or more firing holes or vents, *y*, which may run straight, or more or less an-

gling, as shown. At this end of the air-chamber the fulminate to ignite the charge is to be exploded. In the drawing I have represented this to be done by means of a firing-pin, B, the head of which is made to fit snugly in the upper unperforated part of the air-chamber, but it is, of course, evident that any other firing device that will answer the same purpose, may be substituted. As the fulminate is exploded, the fire is communicated through the holes or vents *y* to that part of the charge directly behind the projectile, or between the projectile and the end of the air-chamber, and the head of the firing-pin, fitting as described in the end of the air-chamber, prevents the fire from running backward into the air-chamber, and igniting the charge through the perforations X.

The charge burns backward from behind the projectile. The result is that the air in the air-chamber becomes compressed, and, being elastic, takes off that part of the recoil, and sudden or unequal strain caused at first fire by the inertia of the projectile; then, as the charge continues to burn backward and past the point shown by dotted lines O, the air becomes heated and expands, augmenting the projectile force, and the air then, by means of the oxygen present, causes instant and perfect combustion of the remaining portion of the charge, and thereby greatly increases the explosive and projectile force of the powder, and secures to the projectile a greater velocity and range.

Having thus fully described my invention, what I claim as new, and desire to secure by Letters Patent, is—

The combination of the perforated air-chamber A, and a firing device, B, constructed to ignite the charge at the extreme front end of the air-chamber, and prevent the fire from passing back into the same, substantially for the purposes herein set forth.

THOMAS MAC NEIL.

Witnesses:

JNO. J. HERON,
WILLIAM DEPLITCH.