

H. PRICKETT.  
Portable-Fences.

No. 160,711.

Patented March 9, 1875.

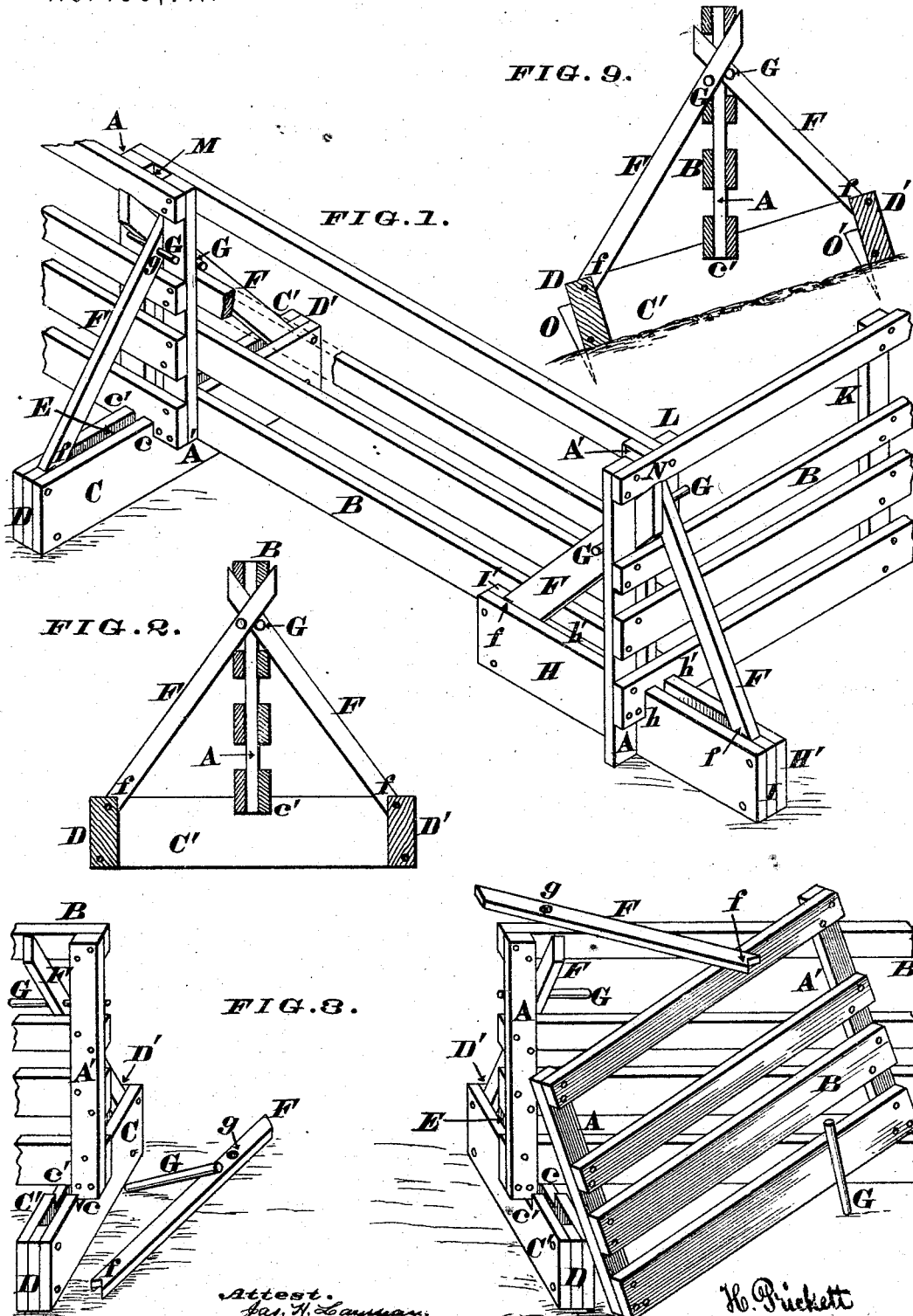

Attest.  
Jas. H. Layman,  
Henry Turner

H. Prickett  
By His Attys.

H. PRICKETT.  
Portable-Fences.

No. 160,711.

Patented March 9, 1875.

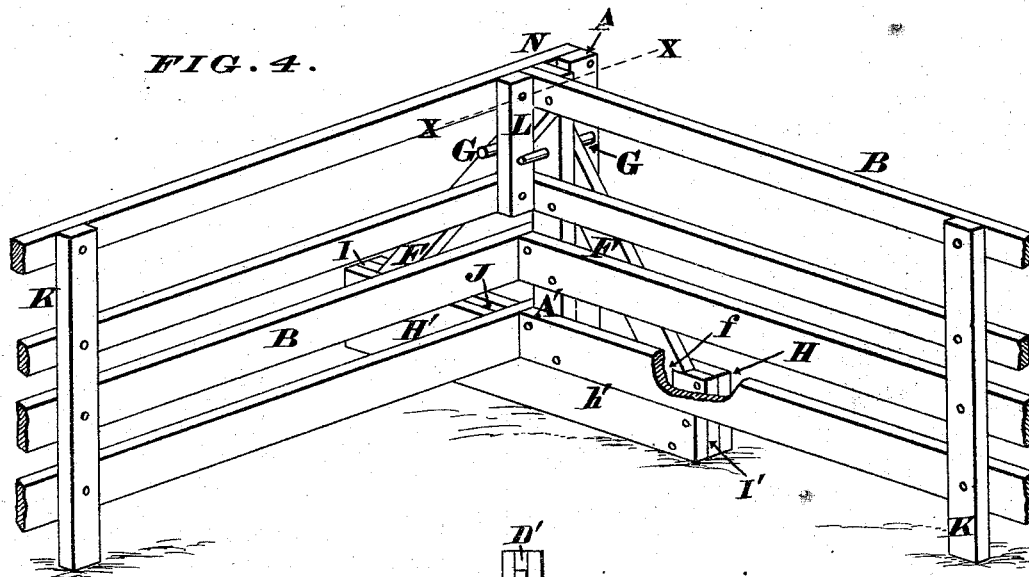

FIG. 4.

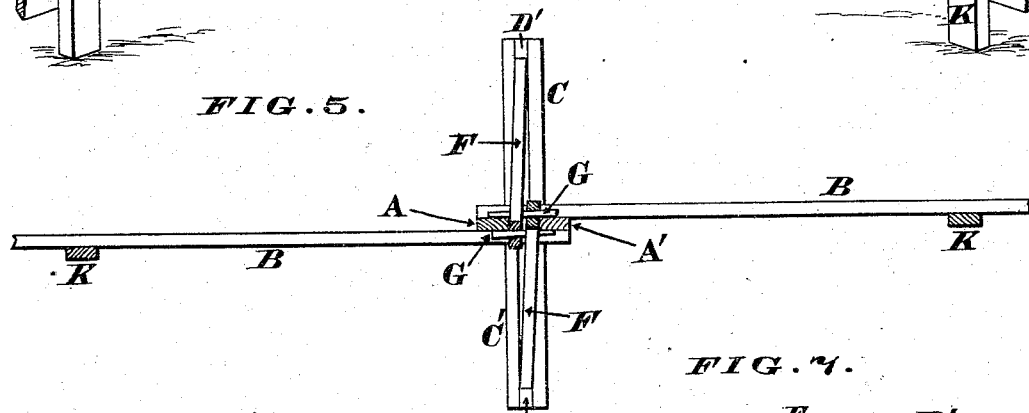

FIG. 5.

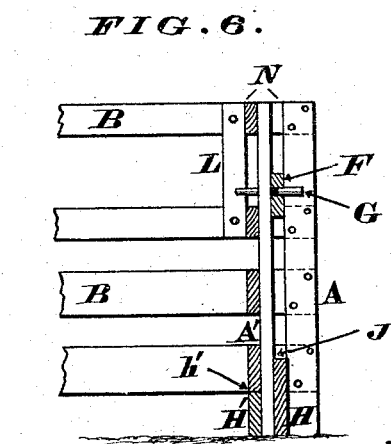

FIG. 6.

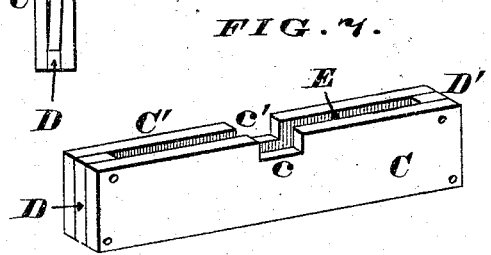

FIG. 7.

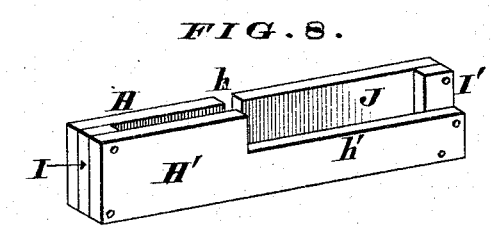

FIG. 8.

Attest.  
Geo. H. Layman,  
Henry Tanner.

H. Prickett  
By Knight & Co. Att'ys.

# UNITED STATES PATENT OFFICE.

HIRAM PRICKETT, OF EDENTON, OHIO.

## IMPROVEMENT IN PORTABLE FENCES.

Specification forming part of Letters Patent No. **160,711**, dated March 9, 1875; application filed December 5, 1874.

*To all whom it may concern:*

Be it known that I, HIRAM PRICKETT, of Edenton, Clermont county, Ohio, have invented a new and useful Portable Fence, of which the following is a specification:

My improvement relates to a fence the sills, panels, and braces of which are capable of being entirely separated one from the other by merely withdrawing the retaining-pins from the braces. My improvement consists in an excavated and blocked sill, which supports the panels and braces. The braces are notched to fit the block of the sill, and perforated at their upper ends to receive retaining-pins.

Figure 1 is a perspective view, showing the manner of making a corner and running a straight stretch with my improved form of fence. Fig. 2 is a vertical section through the fence in the plane of the inclined braces. Fig. 3 is a perspective view, showing one panel detached from the fence. Fig. 4 is a perspective view, showing an inside view of the fence-corner. Fig. 5 is a horizontal section through two contiguous panels in the plane of the locking-pins. Fig. 6 is a vertical section at the line *x*. Fig. 7 is a perspective view of one of the sills detached from the fence. Fig. 8 is a perspective view of one of the corner sills, and Fig. 9 represents the manner of building my fence on a hill-side.

Each panel of my fence consists of two posts or beams, *A A'*, to which are securely nailed as many boards *B* as may be necessary to make the fence close enough to prevent the ingress or egress of live stock. In attaching these boards to the posts care must be taken to leave rather more space between the top board and the one immediately below it than between any of the other boards, the object of this space being hereinafter fully explained. With this exception, the various panels composing my fence are substantially the same as those in use in the ordinary structures of this character. The entire weight of the fence is sustained by sills, which are constructed as follows: *C C'* represent two stout planks, which are maintained a sufficient distance apart and parallel with each other by means of blocks *D D'*, secured to the ends of said planks. By this means an interval or space, *E*, is formed between the two planks, for a purpose which will presently ap-

pear. The upper edges of these sills are excavated, respectively, at *e e'*, which excavations may be of any suitable depth, and long enough to admit the lower extremities of the post and two of the lower boards of the contiguous panels of the fence, as shown in Fig. 2. *E* represents braces, which are long enough to reach, when inclined, from the ends of the sills to about the top of the uppermost boards of the fence. The lower ends of these braces are notched at *f*, in order that they may have a secure bearing upon the upper inner edges of the blocks *D D'* when the fence is erected. The aforesaid braces are perforated at *g* for the reception of pins *G*, which can be readily inserted in said holes, and as easily withdrawn when occasion requires. The sills that are to be located at the angles or corners of the fence are essentially the same as the other sills, being composed of two planks, *H H'*, having blocks *I I'* secured between them, so as to form an interval, *J*. The plank *H* is excavated at *h* to receive one of the lower boards of the fence, while the other plank *H'* has about one-fourth of its material cut away at *h'*, as more clearly shown in Fig. 8. The object of thus cutting away the plank *H'* is to secure a bearing for that board of the fence which runs at right angles to the one that is seated in excavation *h*, as seen in Fig. 4. When the fence is composed of long panels, battens *K* may be applied to prevent the boards sagging down near their mid-lengths. *L* is a cleat that assists in maintaining the corner of the fence in an erect position. *O O'* are stakes driven into the ground for the blocks *D D'* to bear against when the fence is built upon a hill-side. These stakes, however, are not necessary where the ground is level.

In erecting my improved portable fence the sills *C C'* are first placed upon the ground at suitable intervals, and without being staked or otherwise secured, provided the structure is not to be built upon a hill-side or very rolling ground. The panels are then seated in the excavations *e e'* of said sills, care being taken to leave a suitable space, *M*, between the contiguous posts *A* and *A'*, to admit the braces *E*, as shown at the left in Fig. 1. The braces are first passed through the opening below the uppermost board of the fence, and their lower notched ends *f* are then shouldered against the

upper inner edges of blocks D D'. This having been accomplished, the pins G are then driven into the holes *g* of the braces, which act completes the erection of a single panel, and the above-described operation is repeated until the entire fence is completed, provided it is a straight one; but where an angle or corner is to be turned the manner of construction is somewhat different. To form an angle in the fence the sill H H' is located in its proper position, with the lower board of the fence resting upon the bearing formed by the elongated excavation *h'*. The panel which is to run at right angles to the one just placed in position is then applied to the corner sill in such a manner that the bottom board of said new panel abuts against the outer end or shoulder of excavation *h'*, and also rests within the recess *h*. The braces F are then shouldered upon the blocks I I', the pins G driven in, and the corner of the fence is at once completed, as shown in Figs. 1, 4, and 6. In forming this corner an interval, N, is left between the post A and cleat L, which space is wide enough to admit the post A' and the two inclined braces F. (See Figs. 1 and 4.) When the corner is thus formed the lower end of post A' enters the recess J between the sills H and H', and thereby assists in maintaining the two panels of the fence at right angles to each other.

It will be noticed that the entire weight of the various panels constituting my fence is supported by the sills, and not by the braces, the latter being provided simply for the purpose of maintaining the end posts A A' in an erect position. This is the great advantage which distinguishes my fence from all other portable fences whose panels are supported upon oblique shoulders formed in the braces, as it is evident the weight of the panels will soon break off these shoulders and allow the fence to fall, besides which, when a fence thus

supported shrinks to any considerable extent, the panels are frequently lifted out of the sills, and the fence is then readily thrown down either by wind or animals. It will be seen, however, that no shrinkage of my panels can ever dislodge them from the sills within which they are seated, as the pins G will allow sufficient play for the posts A A', to compensate for any possible amount of swelling or shrinkage of the lumber. Longitudinal displacement of the panels is prevented by the braces F entering the recesses E and M, thereby locking the fence securely together.

It will also be noticed that there are no iron pins, keys, wedges, links, or shackles employed in my fence, and on this account it can be constructed and erected by any farm-hand, thus enabling it to be furnished at a very reasonable price. This absence of keys, wedges, &c., renders it an easy matter to take down any panel for the purpose of driving a team through. This is done by simply slipping out two of the pins G, removing two of the braces F, and then lifting the panel bodily out of the excavations *e e'*, and over the protruding ends of the other two braces, as seen in Fig. 3.

After the team has passed through, the panel can be restored to its previous position and secured in place in a few minutes.

I claim as my invention—

The excavated and blocked sill H *h* H' *h'* I I' J, removable, notched, and perforated braces F *f g*, and pins G, in combination with the removable panels A, A', B, and L, as and for the purpose specified.

In testimony of which invention I hereunto set my hand.

HIRAM PRICKETT.

Attest:

GEO. H. KNIGHT,  
JAMES CROSSON.