

C. L. TRAVIS.  
Grain-Binder.

No. 160,732.

Patented March 9, 1875.

Fig. 1.

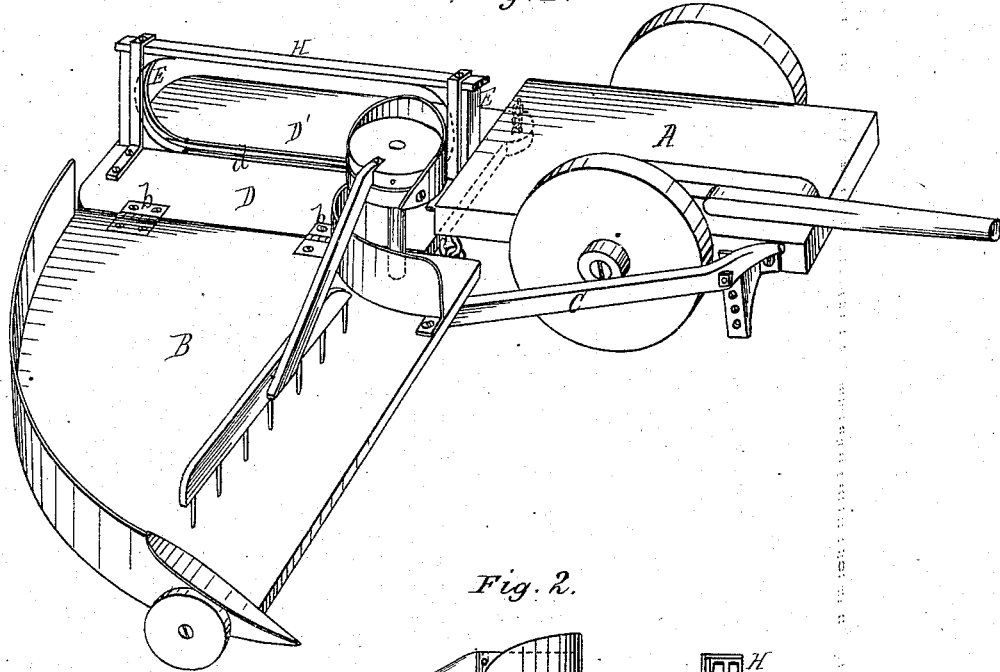

Fig. 2.

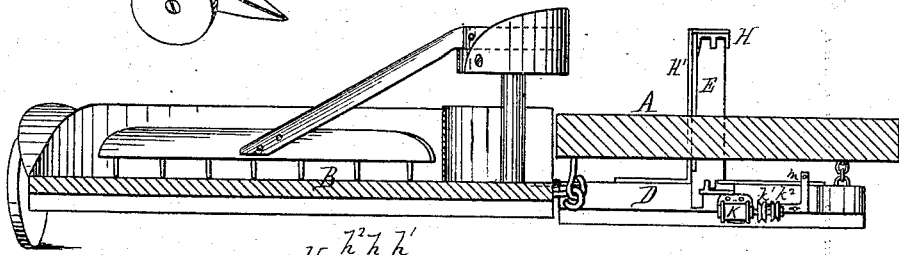

Fig. 7.

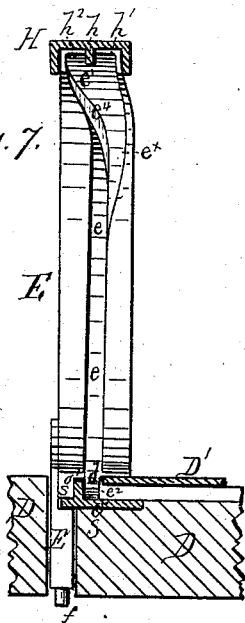
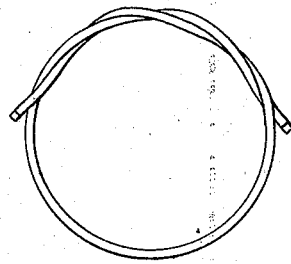

Fig. 8.



Witnesses:  
 Alex Mahon  
 H. C. Barclay

Inventor:  
 C. L. Travis,  
 by A. M. Smith,  
 Attorney

C. L. TRAVIS.  
Grain-Binder.

No. 160,732.

Patented March 9, 1875.

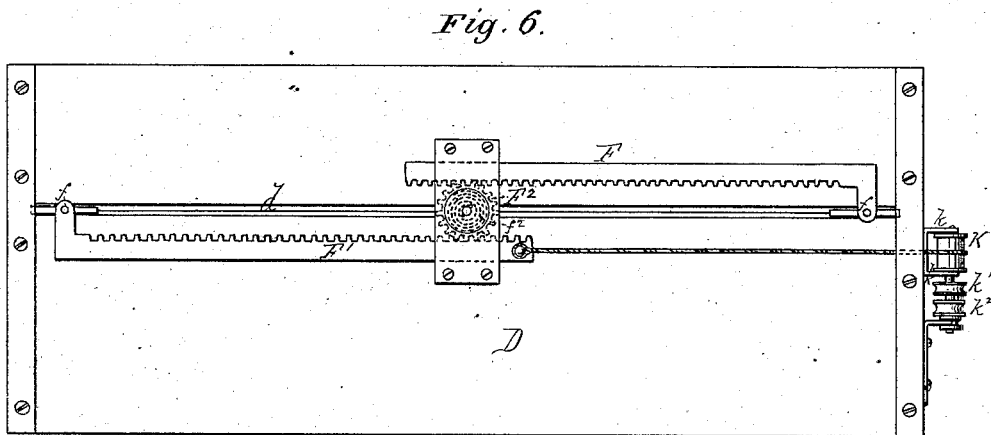
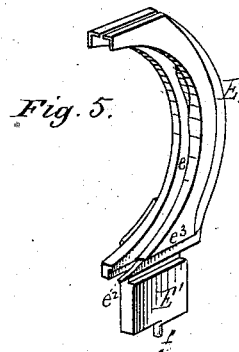
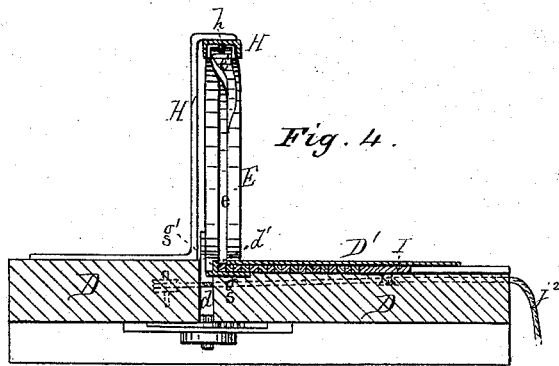
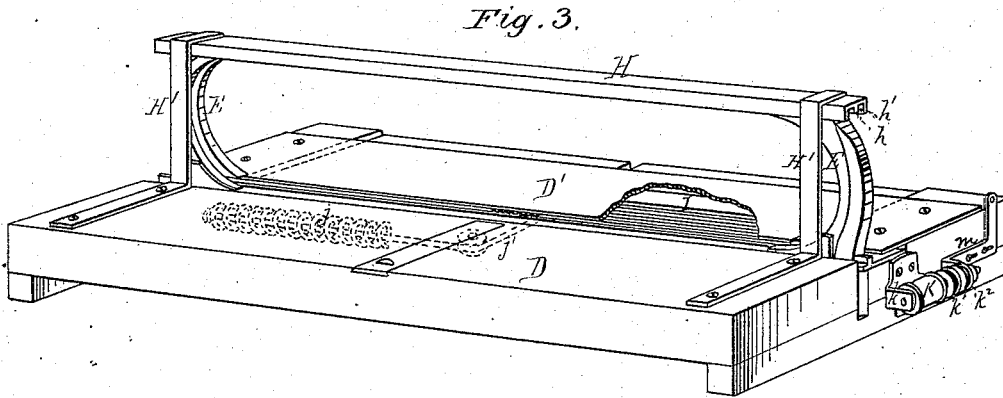

Witnesses:  
 Alex Mahon  
 H. C. Barclay

Inventor  
 C. L. Travis.  
 by A. M. Smith,  
 Attorney

# UNITED STATES PATENT OFFICE.

CHARLES L. TRAVIS, OF GREAT VALLEY, NEW YORK, ASSIGNOR TO GRAIN-BINDER COMPANY, OF FREMONT, OHIO.

## IMPROVEMENT IN GRAIN-BINDERS.

Specification forming part of Letters Patent No. **160,732**, dated March 9, 1875; application filed February 12, 1875.

*To all whom it may concern:*

Be it known that I, CHARLES L. TRAVIS, of Great Valley, county of Cattaraugus and State of New York, have invented certain new and useful Improvements in Grain - Binders, of which the following is a full, clear, and exact description, reference being had to the accompanying drawing making part of this specification, in which—

Figure 1 represents a perspective view of so much of a harvesting-machine as is necessary to show the manner of applying the binder in connection with a hinged quadrant platform. Fig. 2 is a transverse section through the same, showing the manner of supporting the binder's platform or table. Fig. 3 is a perspective view of the binder's platform or table and binding mechanism. Fig. 4 is a vertical transverse section through the same. Fig. 5 is a perspective view of one of the compressing and binding slides or arms detached. Fig. 6 is a bottom view, showing an arrangement of mechanism for operating the compressing and binding arms or slides. Fig. 7 is an enlarged face view of one of the compressing and binding arms, showing the formation of the grooves therein; and Fig. 8 represents the band as it appears after the ends have been united and the band removed from the bundle.

Similar letters of reference denote corresponding parts in all the figures.

The invention relates, first, to the mechanism for passing the bands around the bundles and for uniting the ends of the same; second, to the means for feeding the bands automatically to the binding devices, and to the construction of said devices, whereby they are adapted to automatically take up and apply the bands; and, third, to the construction and general arrangement of the binding devices, whereby they are adapted to be used in connection with any usual or preferred arrangement of the raking mechanism; and the invention consists, first, in a novel construction of the binding-table, whereby it is provided with a receptacle or passage-way for holding the prepared bands and passing them to the compressing and binding slides; second, in a novel construction of the compressing-slides, whereby they are made automatically to pick

up the prepared bands and to pass them around the bundles; third, in a novel construction of the compressing devices, whereby they are made, not only to pass the bands around the bundle, but also to unite the ends thereof by interlacing or twisting the same, as hereinafter explained.

In the drawing, A represents the machine proper, which will include the main frame, driving-wheels, and gearing, and which may be of any usual or preferred construction. B is the grain-platform, of the class known as the quadrant or circular platform, though any other form may be used, if preferred. The platform is connected with the main frame by a drag-bar, C, made adjustable at its forward end for setting the points of the fingers higher or lower, as may be required for working in standing grain or for picking up lodged or fallen grain, the connection of the drag-bar with the adjusting-rack being made a loose or hinged one for permitting a rolling motion of the drag-bar on its longitudinal axis. The heel-end of the drag-bar, or the inner end of the platform, is connected with the main frame by any of the hinged and laterally-bracing connections ordinarily employed for that purpose, the object of this construction being to provide for freedom of movement of the outer end of the platform within certain limits relatively to the movements of the main frame. The rake shown for discharging the grain from this platform is intended to represent one of the Johnston or Dorsey type, in which the raking and gathering arms move around a vertical, or nearly vertical, shaft or pivot, the rakes moving the grain over the platform in the arc of a horizontal, or nearly horizontal, circle. At the inner side of this platform, where the grain is discharged, the binding table or platform D is located, said table being connected with the grain-platform by hinges *b*, which permit the vibrations of the grain-platform, as described, while at the same time they sustain said adjoining side of the table and hold the adjacent edges of the grain platform and table in the same plane, and always in proper relation to each other, for permitting the transfer of the grain from one to the other. The forward end, or outer front

corner of the table D, is suspended by a cord or chain from the main frame, which serves to hold the table at any desired height while permitting slight lateral vibration of the table. The hinges *b* should be set in flush with the surface of the platform B and D, so as not to obstruct the passage of the grain. The table D is divided longitudinally, or is provided with a longitudinal slit or groove, *d*, in which the foot-pieces or shanks *E*<sup>1</sup> of the compressing-slides *E* reciprocate, operated by racks *F*<sup>1</sup> and a central pinion, *F*<sup>2</sup>, or other suitable mechanism, arranged underneath the table and out of the way of the grain, as hereinafter described.

The shanks *E*<sup>1</sup> are cast or otherwise secured upon one side of the compressing-slides *E*, which are thus made to overhang one side or part of the divided table D, the overhanging lower face of the slides moving partly in contact with a flanged way or rail, *g*, which is let into the surface of the table at one side of the groove or slit *d*, and partly overhanging and resting on the surface of the platform above said rail.

The upper ends of the compressing-slides *E* move in a flanged or grooved guide-rail, *H*, supported at its ends from the table D by means of standards *H*<sup>1</sup>, a central rib or flange, *h*, in the guide-rail *H*, entering a central groove or slit in the upper ends of the compressing-slides, for a purpose that will be explained. The inner adjacent faces of the slides *E* are made concave from top to bottom, approaching each a semicircle in form, and this concave face is grooved from top to bottom, the groove *e* terminating at the bottom on a downwardly-projecting rib or lip, *e*<sup>2</sup>, resting upon and moving in contact with the surface of the rail *g* in rear, or at the side of a vertical flange, *g*<sup>1</sup>, thereon. The groove *e* at a point one-third of the distance, more or less, from its upper end, forks or is intersected by a groove, *e*<sup>1</sup>, of increased width and depth, which extends in front of or above the groove *e*, forming an extension thereof, and thence passing to the side of the groove *e*, where diminished in depth it rises above or beyond the bottom of groove *e*, and, converging toward said groove, terminates therein. The grooves in the opposing faces of the two compressing-slides are the same, the grooves *e* as well as the groove *e*<sup>1</sup> in each diverging from the same side; but when facing each other they diverge in contrary directions, or one to the front and the other to the rear. The extreme upper end of the groove *e*<sup>1</sup> is divided centrally by the rib *h* into two parts, *h*<sup>1</sup> *h*<sup>2</sup>, each equal in width to the main groove *e*, and in line with main groove *e* extended, one, *h*<sup>1</sup>, upon the line of the groove in one compressing-slide, and the other, *h*<sup>2</sup>, in line with that in the other slide. The table D in rear of the slit or groove *d* is cut away, except at the ends, to a depth conforming to the depression of the rail *g* below the surface of said platform, and the depression thus formed is covered by a plate or board,

D, except for a short distance back of the rib *g*<sup>1</sup>, which is left open, forming a slot, *d*<sup>1</sup>, between the rib *g*<sup>1</sup> and the forward edge or plate *D*<sup>1</sup> for the passage of the bands, and the space underneath the board D forms a receptacle or passage-way for the bands, which are placed therein, said receptacle or passage-way opening at the rear or outer edge of the table, or at any other convenient point, for the introduction of the bands in any desired quantities. The face of the compressing-arm in rear of the rib *e*<sup>2</sup> is cut away up to the surface of the plate *D*<sup>1</sup>, and the shoulder *e*<sup>3</sup> thus formed rests and moves upon the surface of said plate *D*<sup>1</sup>.

The bands may be of any suitable material, but, by preference, are made of wood, as described in another application of even date herewith, and are placed in the receptacle formed in the platform beneath the plate D, which receptacle is of sufficient depth to receive a single layer of bands, which are brought successively into position in line with the pointed ribs *e*<sup>2</sup> by means of a follower, *I*, actuated by a spring, *j*, and cords *j*<sup>1</sup>, shown in dotted lines, Fig. 3. A cord, *j*<sup>2</sup>, serves to retract the follower *I* when required to replenish the supply of bands. The bands are fed forward by the follower *I* as fast as removed, being held in place until removed by the compressing-slides by the pressure of the follower holding it in frictional contact with the rib *g*<sup>1</sup>.

The action of the compressing-slides in removing and applying the bands is as follows: The lips *e*<sup>2</sup> located in line with the slot *d*<sup>1</sup>, and conforming to the curvature of the inner faces of the slides are brought each to an edge resting on the rail *g*, and when the slides are made to approach each other these edges pass under and lift up the ends of the bands into the grooves *e*, following which, as the compressing-slides are drawn toward each other, the ends are carried up and around the bundle, passing by each other in the parallel grooves *h*<sup>1</sup> *h*<sup>2</sup>, after which they enter the grooves *e*<sup>1</sup> in the opposing slides lifted therein by the sharpened edges with which said grooves terminate when following the bottoms of said grooves. Guided by the inclined or spiral face *e*<sup>4</sup> of the widened portion of said groove the ends are passed each outside of the band. When meeting the rising incline at the bottom and the returning side *e*<sup>x</sup> of the groove, they are turned back and tucked under the band, or between it and the inclosed grain, thus forming a double twist or tuck, one by each end of the band. This action is assisted by the inclosed bundle, which helps to keep the band in position, and to cause the ends to pursue the circular path around it for compressing the bundle and interlocking the ends, as described.

The stiffness of the material employed for the bands further assists this operation by causing the ends to follow closely the bottom of the grooves in the compressing-slides, and this stiffness of the bands, also, in connection with the pressure of the bundle thereon, pre-

vents the ends from becoming released when the compressing-slides are withdrawn, and the band is thus made to effectually secure the bundle without the aid of any twisting or tying mechanism other than the peculiar conformation of the guiding-grooves, as shown and described.

The devices for actuating the compressing-slides E, as stated above, consist of racks F<sup>1</sup>, connected each with a central pinion and with actuating mechanism, as hereinafter described. These racks, by preference, are rigidly connected with the slides to prevent dragging or binding of the latter; but in the drawing are shown connected therewith by pins or spurs *f* passing through eyes or perforations in the ends of the slides. The slide-racks F<sup>1</sup> engage with a central pinion, F<sup>2</sup>, on opposite sides thereof, so that they shall move simultaneously in opposite directions for drawing the compressing-slides together for compressing and binding the grain, or for separating them to release the bundle, and to receive another gavel. The mechanism for actuating these racks, for drawing them together, as shown, consists of a drum, K, at the forward or main-frame end of the table D, secured rigidly to a shaft, which is mounted in bearings *k*, so as to rotate freely therein. Upon the same shaft with the drum K is a clutch-pulley, *k*<sup>1</sup>, also keyed or otherwise rigidly secured to the shaft, and adjacent to this, on the same shaft, is a loose clutch-pulley or sprocket-wheel, *k*<sup>2</sup>, to which motion is imparted from any convenient arrangement of driving-pulley or sprocket-wheel on the main drive-wheel or other axle of the machine by an endless band or chain. When the wheels or pulleys *k*<sup>1</sup> *k*<sup>2</sup> are clutched together the drum K will be rotated and a cord or chain, L, connecting said drum with the rack-bar F<sup>1</sup>, winding up on the drum, by such rotation draws the rack with its compressing-arm inward, and said rack, acting through the pinion F<sup>2</sup>, causes the rack F to move in the reverse direction, thus drawing the compressing-slides E together and applying the bands to the bundle, as described. This accomplished, the clutch-wheel *k*<sup>2</sup> is released from the wheel *k* and a spring arranged either within the pinion F<sup>2</sup>, as shown in dotted lines at *f*<sup>2</sup>, Fig. 6, or, in other convenient position, serves to retract the racks, and therewith the slides E, for releasing the bound bundle, and for bringing them into proper position to receive another gavel. The clutch-wheel *k*<sup>2</sup> is moved into or out of clutch with the wheel *k*<sup>1</sup> by a slide, *m*, which, in practice, will be operated by tripping-levers arranged to intercept the rake-arm just after it has deposited the gavel between the compressing-slides E, and as it rises to pass the main frame for engaging the clutch and drawing the compressing-arms together, and this action of the rake-arm upon one tripping-arm will be made to set a second arm for releasing the clutch through the action of one of the following gathering-arms

of the rake. Any convenient arrangement of tripping-levers may be employed for this purpose.

I have now shown how the invention may be carried out in practice; but it will be obvious that other arrangements of mechanism than that described may be employed for actuating the compressing and binding-arms, and that such mechanism may be made to give a positive movement in both directions to said arms, or the action of the spring described may be reversed, and, further, the extent of the inward or approaching movement of said arms may be made self-adjusting or yielding by means of a yielding connection with the driving-drum for adapting their movement to the size of the gavels operated upon.

It will also be apparent that the binder described may be used in connection with other forms of grain-platform, and other constructions of raking apparatus; but I have preferred to describe it in connection with the quadrant platform, where the greatest difficulties existed in the way of its application.

The form, location, and capacity of the band-receptacle also may be varied—as, for instance, a hopper may be placed at the rear or outer edge of the binding-table, where it will be out of the way of the grain, and the bands placed therein may be fed automatically, one at a time, underneath the plate D', to the binding-slides, by devices connected with and timed to the movements of said slides; or the receptacle may be applied at the upper ends of the compressing-slides by reversing the position of said slides, so that they can take the bands from above.

Further by the employment of vertical followers, in connection with the feeding-follower described, several layers of bands may be contained in the receptacle, the layers being brought successively into position as fast as the preceding layers are exhausted.

Having now described my invention, what I claim as new, and desire to secure by Letters Patent, is—

1. The grooved compressing-slides E, provided with the spurs *e*<sup>2</sup>, whereby they are adapted to pick up the ends of the bands and to pass them in opposite direction around the bundle, substantially as described.

2. The compressing-slides E E provided on their inner adjacent faces with the oppositely-diverging grooves *e*, for guiding the opposite ends of the prepared bands in their movements around the bundle, as described.

3. The grooved compressing-slides E, in combination with the double-grooved guide-rail H, for guiding the ends of the bands and passing them by each other, substantially as described.

4. The compressing-slides E, provided with the grooves *e* *e*<sup>1</sup>, the latter of varying depth, as described, whereby they are adapted, in connection with the grooved guide-rail H, to not only pass the ends of the bands around the bundle in compressing the same, but also

to unite or tie said ends, substantially as described.

5. The combination, with the compressing-slides E, of a receptacle or passage-way for the prepared bands, through which said bands are conveyed to the compressing-slides.

6. The compressing-slides E, in combina-

tion with racks F F<sup>1</sup>, for actuating the same, as described.

C. L. TRAVIS.

Witnesses:

ALEXANDER MAHON,  
H. C. BARCLAY.