

W. DOYLE.  
Stove.

No. 160,755.

Patented March 16, 1875.

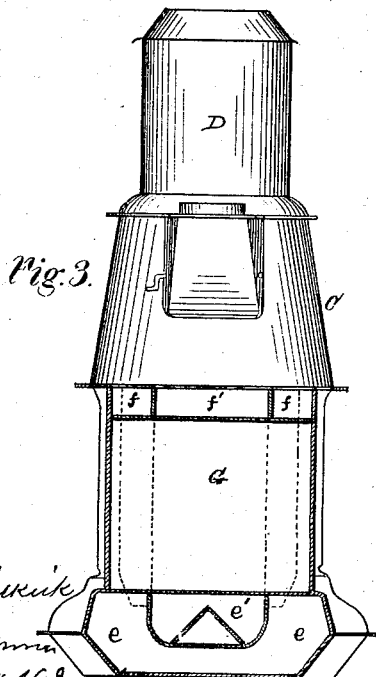
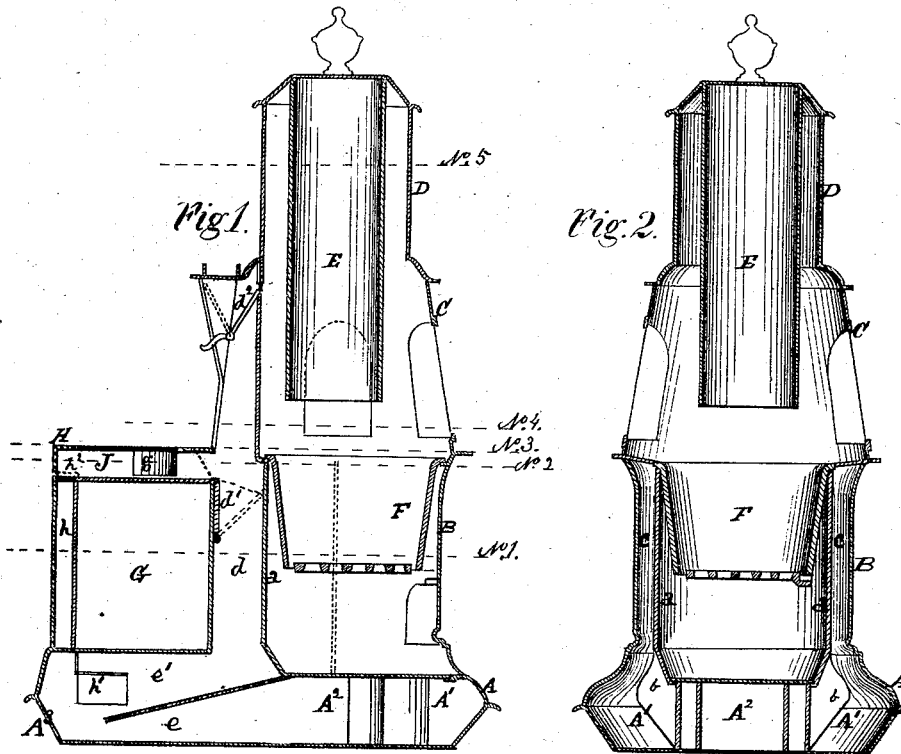

Witnesses: {  
 Chas. J. Leuker  
 James Connor  
 Edward N Doyle  
 James Wright

William Doyle  
 by his attorney  
 Chas. Leuker  
 Inventor.

W. DOYLE.  
Stove.

No. 160,755.

Patented March 16, 1875.

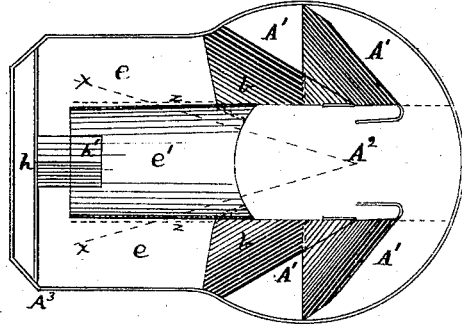

Fig. 4.

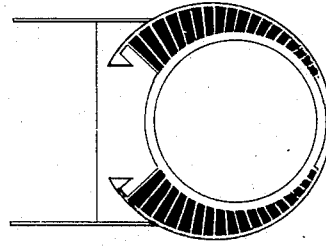

Fig. 7.

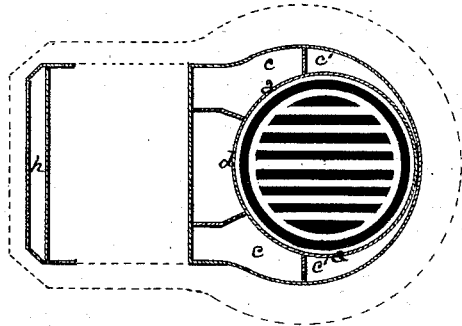

Fig. 5.

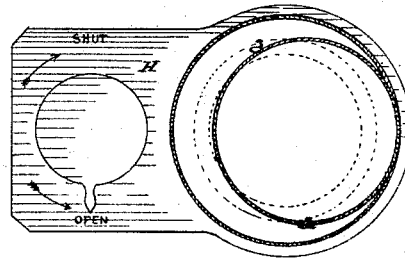

Fig. 8.

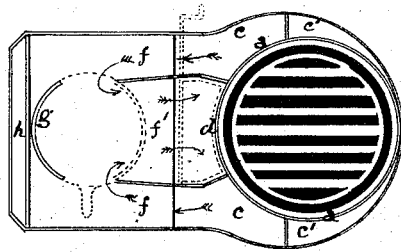

Fig. 6.

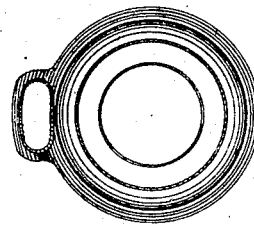

Fig. 9.

Witnesses {  
Leb. J. Siskin  
James Brown  
Edward H. Doyle  
James Knight

William Doyle  
by his attorney  
Alex. Siskin  
Inventor.

# UNITED STATES PATENT OFFICE.

WILLIAM DOYLE, OF ALBANY, NEW YORK.

## IMPROVEMENT IN STOVES.

Specification forming part of Letters Patent No. **160,755**, dated March 16, 1875; application filed December 16, 1874.

*To all whom it may concern:*

Be it known that I, WILLIAM DOYLE, of the city and county of Albany, State of New York, have invented certain new and useful Improvements in Base-Burning Parlor Cook-Stoves; and I do hereby declare that the following is a description thereof, reference being had to the accompanying drawings forming a part of this specification, in which—

Figure 1 represents a sectional elevation of the stove, taken from front to rear. Fig. 2 is a sectional elevation taken from side to side. Fig. 3 is a lateral sectional elevation of the oven section of the stove, with the body of the stove in front of the oven. Fig. 4 is a plan view of the base-flues of the stove. Fig. 5 is a horizontal sectional view taken at line No. 1 in Fig. 1. Fig. 6 is a horizontal sectional view taken at line No. 2 in Fig. 2. Fig. 7 is a horizontal sectional view taken at line No. 3 in Fig. 1. Fig. 8 is a horizontal sectional view taken at line No. 4 in Fig. 1. Fig. 9 is a horizontal sectional view taken at line No. 5 in Fig. 1.

My invention relates to that class of stoves known as parlor cook-stoves; and consists in the several devices, parts, and combinations hereinafter described, so arranged in their relation to each other as to render the stove proper capable at all times of having the draft reverted into its base for effective operation for warming purposes, and at the same time of conducting the hot gases about the oven, to heat the same, for cooking purposes, or for boiling, or both.

To enable others skilled in the art to make and use my invention, I will proceed to describe it in reference to the drawings in two sheets, and the letters of reference marked thereon, the same letters indicating like parts.

In the drawings, A represents the base section of the stove, inclosing the side flues and return-flues A<sup>1</sup> A<sup>1</sup>. B is the fire-pot section or wall inclosing the descending side flues leading into the base from the combustion-chamber, the fire-pot, and ash-pan chamber. C is the mica section inclosing the combustion-chamber and the lower portion of the fuel-reservoir. D is the top section inclosing the upper portion of the fuel-reservoir. E is the fuel-reservoir suspended over the fire-pot

F, which fire-pot is suspended or supported forward of a vertical central line of the fuel-reservoir or eccentrically with the same, and is inclosed by the plates or casing *a*, (shown in Figs. 1, 2, 5, and 6,) which plate or plates form the inner wall of the descending flues *c c'* and the ascending flue *d*. In this invention I extend the base-plate or lower portion A<sup>3</sup>, comprising the lower portion of the stove, out laterally at its rear, as shown in Figs. 1 and 4. Above the said extended portion A<sup>3</sup> is placed the portion G, provided with one or more doors. In the extended base A<sup>3</sup>, and beneath the said oven, are made the side flues *e e* and the return-flue *e'*. The side flues *e e* receive the gases from the central return-flue A<sup>2</sup> in the base proper by their passing from the said central flue beneath the curved plates *b b* into the said side flues, to escape at the rear of the base A<sup>3</sup> into the return-flue *e'* beneath the oven, and thence pass into the ascending flue *d*. The return-flue *e'* is preferably formed by a plate made in the form shown in Figs. 1, 3, and 4, in which the bottom of the said plate is raised at a distance from the bottom plate of the base A<sup>3</sup>, so that the hot gases from the central return-flue A<sup>2</sup> may circulate in part beneath, while the sides of the said plate extending up to the oven bottom form the division-plates for the separation of the flues *e* and *e'*. Placed in the ascending flue is a damper, *d<sup>1</sup>*, which when opened, as shown by full lines in Fig. 1, will permit the hot gases to ascend to the exit when the damper *d<sup>2</sup>* is closed up, reverting the draft.

Made above the oven G, and between the said oven and the top plate H, is the flue-chamber J, which is divided into flues *f f*, for the passage of the hot gases from the flues *c c* into the said flue-chamber and the return-flue *f'*, for the return of the hot gases toward the front, and into the ascending flue *d*, as indicated by arrows in Fig. 6. The top plate H is provided with a pot-hole having a ring-damper, *g*, which ring-damper, when turned, as shown by full lines in Fig. 6, will permit the hot gases to enter the flue-chamber J from the side flues *c c* through the side flues *f f*, and circulate beneath the pot-hole, and escape thence through the return-flue *f'* to the ascending flue *d*; but when the said ring-

damper is turned to position shown by dotted lines in Fig. 6, and by full lines in Fig. 1, the hot gases will be prevented from having a passage to the ascending flue in that direction.

At the rear of the oven is made a flue, *h*, which leads from the flue-chamber *J* into the rear of the base below the oven, as shown in Fig. 1, and communicates with the central return oven-flue *c'* by the hooded flue *h*<sup>1</sup>. A partial closing of the ring-damper will permit a degree of circulation of the hot gases beneath the pot-hole, and a passage to the ascending flue, and at the same time permit another portion of the hot gases to pass down the rear descending flue *h*. When the damper *d*<sup>2</sup> is closed, as shown by full lines in Fig. 1, and the damper *d*<sup>1</sup> is closed, as indicated by dotted lines in same figure, the hot gases will pass directly from the flues *c c*, through the flues *f f*, to the space beneath the pot-hole, and return direct to the ascending flue *d*, through the flue *f'*, provided the ring-damper is placed as shown by full lines in Fig. 6, when no other parts of the stove will be heated by the currents of hot gases with the other flues, and the draft will be made nearly direct, as their circuit from the flues *c c* to the exit will be short. When the damper *d*<sup>1</sup> is opened, a portion of the hot gases will descend the flues *c' c'*, and pass into the front side flues *A*<sup>1</sup> *A*<sup>1</sup>, and thence into the central return flue *A*<sup>2</sup>, and thence back beneath the plates *b b*, Fig. 4, into the side flues *e e* beneath the oven to the rear of the same, and enter the central flue *e'*, and thence pass forward to the ascending flue *d* to escape to their exit. While the hot gases entering the said side flues *e' e'* thus pass to their exit, another portion of the hot gases entering the flues *c c* will pass back and over the oven, through the flues *f f*, and descend the rear oven-flue into the base, to be discharged through the hooded flue into the central flue *e'*, and be carried by the draft of the other gases, and with the same, up the ascending flue. When the ring-damper is open, and the other dampers are permitted to be as last described, a portion of the hot gases will pass through the flues in the base of the stove proper, and beneath the oven, while another portion will pass, beneath the pot-hole, thence to the ascending flue. With a damper, *h*<sup>2</sup>, to close the rear oven-flue *h*, shown by dotted lines in Fig. 1, all the hot gases will be reverted and made to circulate through the several base flues, and beneath and front of the oven, when the damper *d*<sup>1</sup> is opened and the damper *d*<sup>2</sup> is closed.

It is readily seen that, by these improvements, the oven may be heated for baking purposes at the same time the base of the stove proper is heated for warming purposes, by either passing all the hot gases in contact with the bottom plate and front plate of the said oven after their passage from the base flues of the stove proper, or that the oven and a vessel set in the pot-hole may be heated at the

same time, and also at the same time the base of the stove proper is being heated; it is also further seen that, if desired, all the rear, front, top, and bottom plates of the oven may also be heated when the base of the stove proper is being heated; or, if desired, the hot gases may be made to circulate only beneath the pot-hole for the heating of any vessel set therein.

The advantages attending these improvements are obvious, and are, first, a heating of a greater amount of surface for radiation of heat for warming a room; second, the oven may be heated for baking purposes at the same time the stove proper has its base heated for warming purposes; third, the oven and base of the stove proper may be heated for their purposes the same time the hot gases are made to circulate beneath a vessel that may be placed in the pot-hole; fourth, a vessel may be heated setting in the pot-hole without the oven or the base of the stove proper being heated, as may be desired in warm weather. These advantages give to the stove features which are not found in stoves of this class as heretofore made, and enable a housekeeper or other person to direct the hot gases to such parts as may be desired to be heated, and in greater or less volumes, as the purposes may require, whether in light or strong baking, or boiling, or warming.

It is to be understood that the curved plates *b b*, used by me in this stove, and also the ring-damper *g*, form in themselves no part of this invention, as they belong to other inventions made by myself, for which Letters Patent have been granted, and are only used in this invention in combination with different parts not before used with them. In this invention the curved division-plates *b b* are used to stimulate the currents of hot gases passing from the central base-flue to the side flues in the base beneath the oven, whereas in their original place they were used to stimulate the current in the ascending flues. The ring-damper also used in this invention is to effect a horizontal reverting of the currents of hot gases from the front of the fuel-chamber to the rear of the pot-hole, and thence back to the ascending flue, which ascending flue is on the same side of the said flue-chamber at which the fire-pot is located, while in its original place and application the said ring-damper was used to direct the passage of the hot-gases beneath or from the pot-holes as they passed through the top flue from the combustion-chamber in front to the exit at the rear.

It is to be understood that I do not confine myself to any particular form of the flues in the extended base *A*<sup>3</sup>, through which the hot gases pass from the flues in the base of the stove proper, to heat the bottom plate of the oven on its lower side in their passage from the said flues in the said base of the stove proper to the ascending flue, provided the flues in the said extended base are arranged in such a manner that the hot gases from the

base of the stove proper will pass beneath the bottom plate of the oven, and impinge in part upon the same, and pass thence to an ascending flue placed between the oven and the fire-pot. It is evident that the flues *e e* and *e'* may be variously arranged for this purpose without disturbing or interfering in any way with either the side flues or the return-flue in the base of the stove proper, or the ascending flue between the oven and the fire-pot, and that any of the usual arrangement of flues heretofore used beneath ovens for the passage of the gases may be used, such as two horizontal sheet-flues, the lower leading from the flue  $A^2$  in the base of the stove proper to the rear of the extended base  $A^3$ , and an upper sheet-flue communicating from the said lower sheet-flue to the ascending flue in the front of the oven; or, again, the flues may be formed by division-plates set angularly in the said extended base, as indicated by dotted lines *x x* in Fig. 4, which would secure in the said base the necessary side and return flues; or, again, two division-plates, *z*, Fig. 4, running parallel with each other, which will conduct the hot gases from the central flue  $A^2$ , beneath the plates *b*, through side flues outside the said strips, to be returned through the central space or flue between; or, again, by a curved plate, so arranged as to form two flues, or for the passage of the gases to the rear of the base, and the other for their passage forward from thence to the ascending flue.

Any or all of the said modes of construction may be used as a part of the invention in lieu of the arrangement of flues shown.

It is to be understood that the rear flue *h*, in this invention, has no connection with the flues *e* or their equivalents, leading from the return-flue  $A^2$  in the base of the stove proper, but only with the return-flue *e'*, leading to the ascending flue *d*, and is to be used in connection with the other flues when it is desired to envelop the whole oven in a direction from over the top of the oven to beneath the same, through the return-flue *e'* to the ascending flue *d*.

Having described my invention, what I claim, and desire to secure by Letters Patent, is—

1. The combination, with a heating-stove proper, of an oven, located laterally at the rear of said stove, and an ascending flue between the said stove proper and the said oven, and of the flue-chamber J, rear flue *h*, and return-flue *e'*, to heat the said oven by the hot gases drawn from the combustion-chamber of the stove proper, and passing over the top, down the rear, and beneath the bottom, of the oven, and up the ascending flue, substantially as set forth.

2. In combination with a heating-stove proper and an oven placed laterally from the same, the flues *e e* and *e'*, or their described equivalents, leading from the flues in the base of the stove proper to beneath the oven, and the flue-chamber J and rear flue *h*, leading from the combustion-chamber, to conduct one portion of the hot gases in a direction down into the base of the stove proper, and beneath the oven, to heat the same, and another portion over the top of the oven, down its rear, and beneath the oven, and among the hot gases led from the base-flues in the base of the stove proper into the ascending flue *d*, substantially as set forth.

3. The combination, with the side flues *e e* beneath the oven and the central return-flue  $A^2$  in the base of the stove proper, of the inclined plates *b b*, beneath which the hot gases may pass to the flues *e e*, substantially as and for the purpose set forth.

4. The combination, with the flues *e e'*, leading from the combustion-chamber, and the ascending flue *d*, located adjacent to the said flues, of the flue-chamber J, provided with the side flues *f f* and return-flue *f'*, and the damper *d'*, to revert the draft beneath a pot-hole and direct the discharge of the hot gases to the exit-flue through the ascending flue, substantially as and for the purpose set forth.

5. The combination, with the flues *f f* and return-flue *f'*, of the ring-damper *g*, working in the flue-chamber J, located in the rear of the ascending flue *d* and the fire-pot, substantially as and for the purposes set forth.

WILLIAM DOYLE.

Witnesses:

EDWARD H. DOYLE,  
JAMES WRIGHT.