

T. T. LOOMIS.  
Steam Pile-Driver.

No. 160,781.

Patented March 16, 1875.

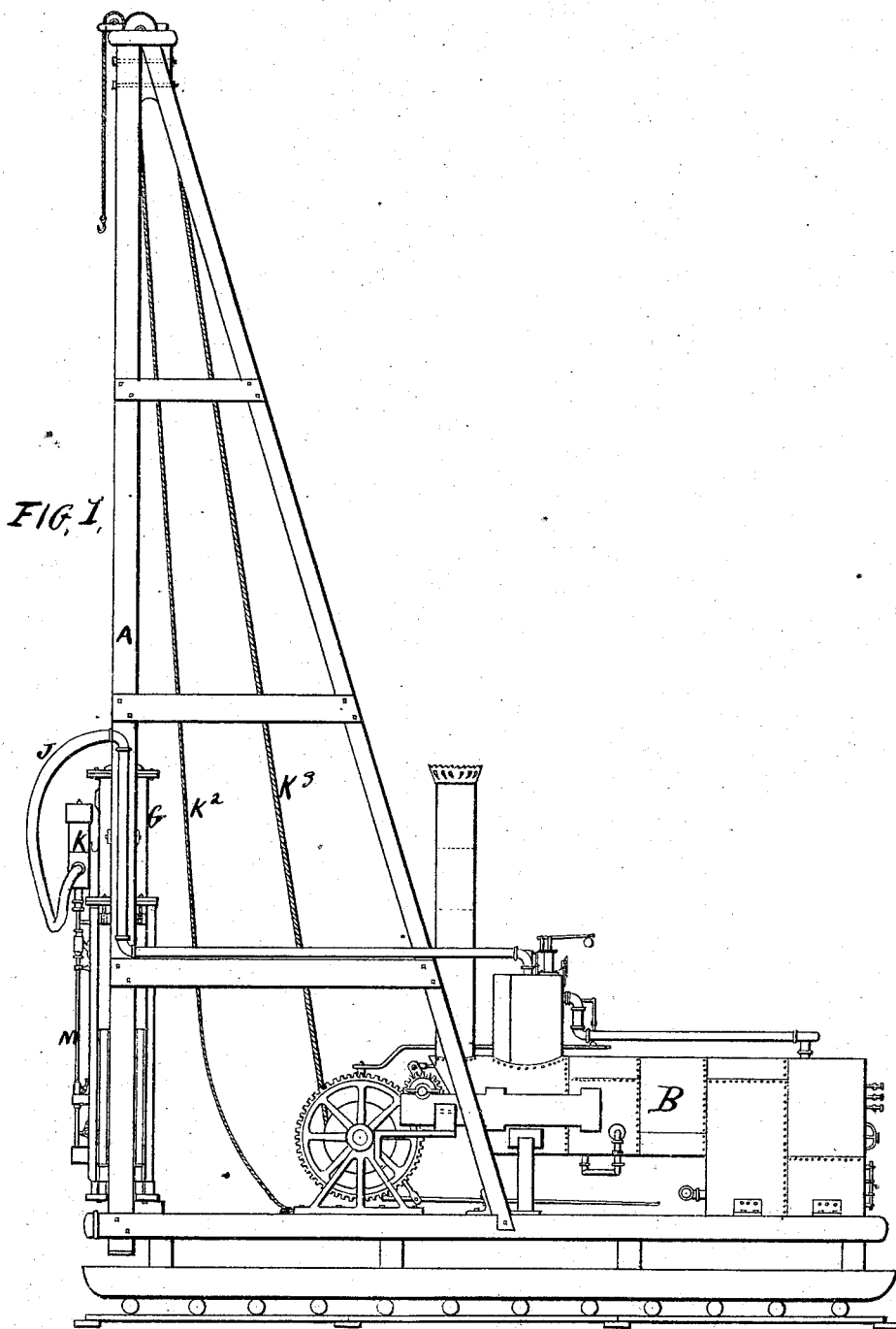

FIG. 1.

Witnesses  
*D. T. Low*  
*Marland L. Perkins*

Inventor  
*Thomas T. Loomis*  
*By Sherman & Co*  
*Attorneys*

T. T. LOOMIS.  
Steam Pile-Driver.

No. 160,781.

Patented March 16, 1875.

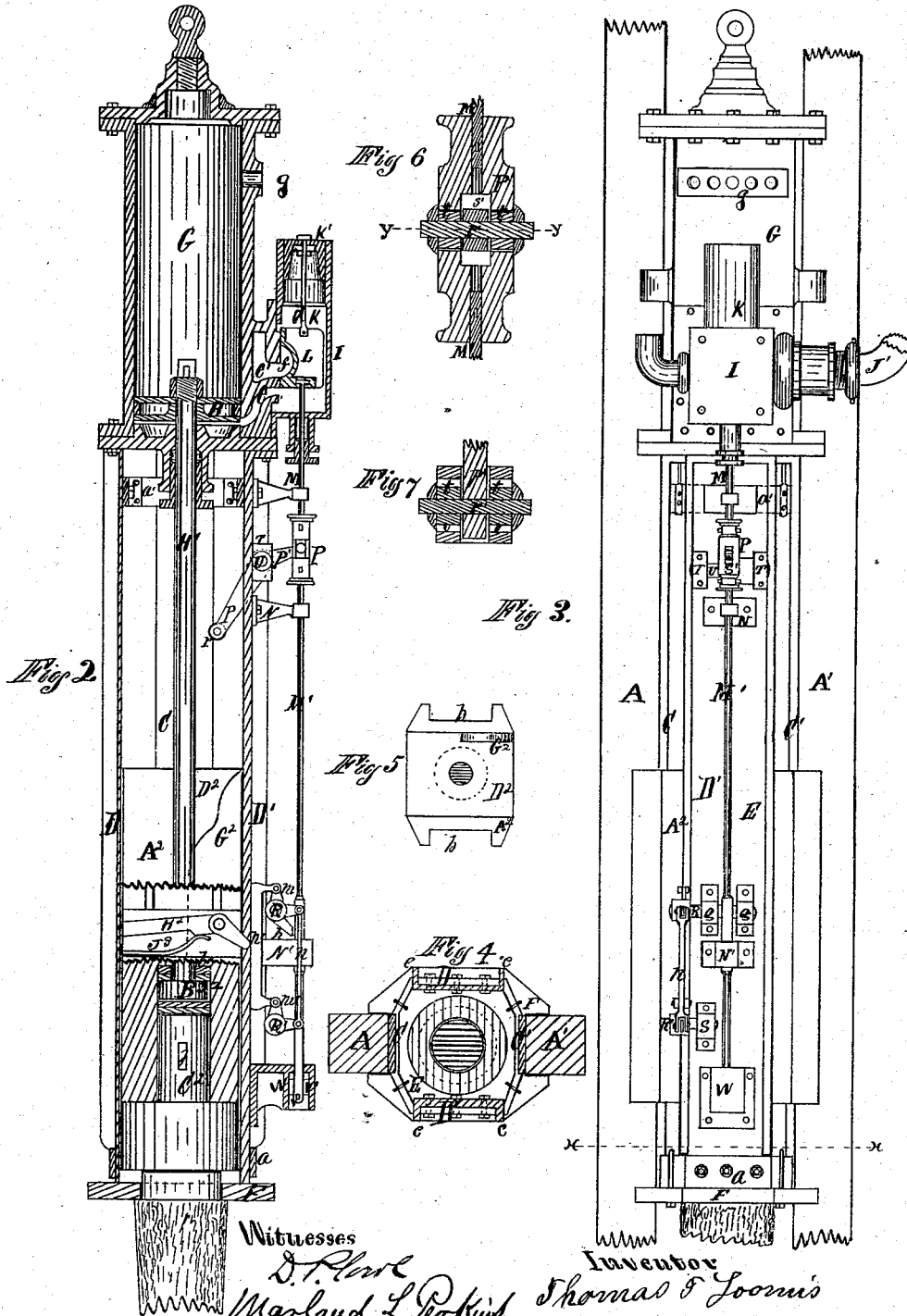

Witnesses  
*D. P. Clark*  
*Marland L. Perkins*

Inventor  
*Thomas T. Loomis*  
*By Chesbrough & Co*  
*Attorneys*

# UNITED STATES PATENT OFFICE.

THOMAS T. LOOMIS, OF CHICAGO, ILLINOIS.

## IMPROVEMENT IN STEAM PILE-DRIVERS.

Specification forming part of Letters Patent No. **160,781**, dated March 16, 1875; application filed January 23, 1873.

*To all whom it may concern:*

Be it known that I, THOMAS T. LOOMIS, of Chicago, in the county of Cook and State of Illinois, have invented a new and useful Improvement in Steam Pile-Drivers; and I do hereby declare the following to be a full, clear, and exact description thereof, which will enable others skilled in the art to which my invention appertains to make and use the same, reference being had to the accompanying drawings forming part of this specification, in which—

Figure 1, Sheet 1, is a side elevation of a steam pile-driver embodying my said improvement, showing its connection with the boiler. Fig. 2, Sheet 2, is an enlarged vertical central section of the same detached from the derrick. Fig. 3, Sheet 2, is an enlarged front elevation of the same attached to the leaders of the derrick. Fig. 4, Sheet 2, is an enlarged cross-section or plan of the same, taken on the line *x x* drawn across Fig. 3. Fig. 5, Sheet 2, is an enlarged top view of the hammer detached from the frame guiding the same. Fig. 6, Sheet 2, is an enlarged vertical transverse central section of the coupling uniting the connecting-rod in the valve-stem; and Fig. 7, Sheet 2, is a cross-section or plan of the same, taken on the line *y y* drawn across Fig. 6.

Similar letters of reference indicate like parts in the several figures of the drawing.

My invention relates to that class of steam pile-drivers in which the cylinder and piston operating the hammer are supported upon a frame resting upon the pile, and so arranged as to descend with the pile as the latter is driven; and to that end it consists, in combination with said frame, of a detachable grooved plate adapted to pass between the leaders and support the frame, and perforated to receive and guide the upper end of the pile, whereby the latter is prevented from being displaced by the concussion of the hammer. It further consists in the combination of the parts constituting the coupling employed in connecting the connecting-rod to the valve-stem, all of which will be more fully set forth in the following description and claims.

In the drawings, A and A<sup>1</sup> represent the leaders of an ordinary derrick, and B the

boiler, all of which are constructed in the usual manner. C C' and D D' are vertical bars of iron, which are made of the requisite length, and are each firmly secured at the lower end to the inner side of a wrought-iron band, *a*, and at the upper end to the outer side of a like band, *a'*, forming a frame, E, having four sides, as shown in Fig. 4. The bars C C' are so arranged as to fit loosely between the leaders A A<sup>1</sup> of the derrick; and the bars D D' are each provided with flanges *c c*, extending at a right angle outward from their side, or they may be made of channel-iron, the object being to insure the requisite lateral strength. F is a flat metal plate, which is provided on opposite sides with a groove, within which the leaders loosely fit. The arrangement of this plate is such as to admit of a free and easy ascending or descending movement between the leaders, and by means of the grooves the plate is prevented from being displaced laterally. This plate is provided at its center with an aperture, through which the upper end of the pile passes, the latter being shouldered to admit of the same, as shown in Fig. 2. The frame E is supported upon this plate, and is so arranged as to rest its entire weight on the pile, and to descend with it, as the latter is driven by the concussion of the hammer. G is the cylinder, which is firmly secured to the upper end of the frame E by means of bolts, which pass through its lower flange and the bars C C' and D D', the said bars being bent in proper shape to admit of the same.

The upper and lower heads of the cylinder are each provided with grooves, arranged in the same vertical plane with the grooves formed in plate F, through which the leaders loosely pass, as shown in Fig. 3. H is the piston, and H<sup>1</sup> the piston-rod, both of which are arranged within the cylinder in the usual manner. I is the steam-chest, which is attached to the outer side of the cylinder, as shown in Figs. 2 and 3. J is the steam-admission pipe, which is attached to the sides of the derrick, and communicates with the boiler, as shown in Fig. 1. To this pipe is attached a steam-hose, J<sup>1</sup>, which communicates with the steam-chest in the ordinary manner. The arrangement of this hose is such as to allow the cylinder to be raised or

lowered to any desired point within the leaders, the object being to allow frame E to be raised when the pile is first placed in position, and to allow the frame and cylinder to descend as the pile is driven. K is a cylindrical steam-chamber, the walls of which are attached to, or made as a part of, the upper extremity of the steam-chest, as shown in Figs. 2 and 3. This chamber communicates with the interior of the steam-chest through an opening in its lower end, and is provided at its upper end with a disk, K<sup>1</sup>. This disk is so packed as to form a steam-tight joint between its periphery and the wall of the chamber, and is so arranged as to admit of a free and easy vertical movement. L is the cut-off valve, which is arranged within the steam-chest in the usual manner. Firmly secured to the upper extremity of this valve is a primary valve-stem, *d*, which extends upward through disk K, and is permanently attached thereto. *e* is the admission-port, through which the steam is admitted from the chest into the cylinder. This port is so arranged as to admit the steam immediately under the piston when at the limit of its downward movement, and as the cut-off valve is raised. *e'* is the exhaust-port, which is so arranged as to communicate with port *e* when the cut-off valve is at the limit of its downward movement, and the steam escapes through an opening, *f*, formed within the inner surface of said valve. The wall of the upper portion of the cylinder is provided with a series of openings, *g*, communicating with the interior of the same, through which the steam is allowed to escape as the piston is raised above the limit of its movement, should the cut-off valve fail to perform its function, thereby preventing injury to the cylinder-head by contact of the piston therewith. Firmly secured to the lower extremity of the cut-off valve is a valve-stem, M, which passes through the lower end of the steam-chest in the usual manner. Firmly secured to the outer side of bar D<sup>1</sup> are boxes N N', within which is secured a vertical connecting-rod, M'. (Shown in Figs. 2 and 3.) Affixed to the upper extremity of this connecting-rod, and to the lower end of the valve-stem M, is a coupling, P. Permanently attached to the said bar D<sup>1</sup>, slightly below box N', are boxes *o o*, within which is secured a rock-shaft, R. Upon this shaft is mounted a pawl, *h*, which takes into a corresponding mortise formed in the connecting-rod M' when said rod has reached the limit of its downward movement. A like box, S, is also secured to the said bar D, slightly below box N', within which is secured a corresponding rock-shaft, R'. Mounted on the end of said rock-shafts R and R' are bell-cranks *m m'*, as shown in Fig. 2. To one of the arms of each of said cranks is pivoted a connecting-rod, *n*, and to the other arm is pivoted a vertical lever, *n'*.

The arrangement of this lever is such as to admit of a parallel movement laterally, by which means, as the said lever is moved outward from the bar, a slight rocking movement

is imparted to the shafts R R', thereby moving pawl *h* from the mortise in connecting-rod M', relieving the rod from its contact with the pawl, and the rod is moved upward by the overbalanced pressure of steam against the disk in the chamber, raising the cut-off valve, which opens the admission-port and the steam enters the cylinder. Permanently attached to bar D<sup>1</sup> are boxes T T, within which is fitted a rock-shaft, U. (Shown in Fig. 3.) Mounted upon this shaft is a lever, *p*, which extends inward toward the center of the frame, and is provided at its inner end with a traverse-pulley, *r*, which is so arranged as to freely revolve on its journal. Firmly secured upon shaft V, or made as a part of lever *p*, is an arm, P', extending horizontally outward from said shaft. This arm passes into a mortise, S', formed through coupling *p'*, and is secured therein by means of a bolt, *r'*, passing through said arm, and secured within adjustable boxes *t t*, affixed within said coupling. These boxes are loosely fitted into mortises *v v*, formed transversely across the coupling, and are so arranged as to admit of a free and easy lateral movement therein, by which means coupling-rod M' and valve-stem M are prevented from being sprung by the change of the angle of arm *p'*, thus insuring a vertical movement of the valve-stem. Firmly attached to bar D<sup>1</sup> is a cushion-box, W, within which are secured layers of wood and rubber, alternately arranged, and through which the lower end of connecting-rod M' passes. A key, *v'*, passes through said connecting-rod immediately under a metal disk, *v''*, upon which the layers of wood and rubber are supported, thus preventing the cut-off valve from rising above the limit allowed, the layers of wood and rubber acting to relieve the concussion as said valve is forced upward by the pressure of steam. A<sup>2</sup> is the hammer, which is made of cast-iron. This hammer is provided on opposite sides with grooves or channels *b b*, as shown in Fig. 5. The arrangement of these grooves is such as to allow the hammer to pass loosely between the bars C C' of frame E and the leaders A A<sup>1</sup> of the derrick, the walls of the grooves bearing against the sides of the leaders and edges of the bars, thus holding the frame in the proper position between the leaders, and at the same time causing the leaders to act as a guide to the hammer. The hammer is provided at its center with an aperture, through which the piston-rod passes. The lower extremity of this piston-rod is provided with a collar, B<sup>2</sup>, which loosely fits the enlarged portion of the aperture in the hammer. Upon this collar are secured two or more annular pieces of hard wood or other suitable packing, which bear against shoulder *l* of the hammer, thus relieving the concussion as the hammer is raised by the upward movement of the piston. The lower portion or face of the hammer is made round, and extends below the lower extremity of the grooves. The upper end of said hammer is

provided with a groove,  $D^2$ , which extends downward to a point slightly above its center and transversely across the same. Upon one side of this groove is formed an incline cam,  $G^2$ , which is so arranged as to come in contact with and against pulley  $r$  on lever  $p$  as the said hammer is raised by the action of the steam.  $H^2$  is a horizontal lever, which is pivoted to the hammer near its side and at the lower extremity of groove  $D^2$ . This lever extends transversely across said hammer, and is so arranged as to come in contact with and against lever  $n'$  as the opposite end of said lever  $H^2$  is moved downward by the concussion of the hammer. Secured to the hammer at the lower edge of the groove is a spring,  $J^3$ , which is so arranged as to bear against the said lever slightly back of its fulcrum, the object of which is to move the lever upward to its normal position after the blow is struck and the hammer is at rest.  $K^2$ , Fig. 1, is the line employed to lift the frame  $E$ , and  $K^3$  is the line employed to lift the pile into place between the leaders, both of which are operated in the usual manner.

The operation is as follows: Frame  $E$  and the cylinder are first placed between the leaders  $A A^1$ , and are raised to a sufficient height to allow the pile to be arranged vertically between the leaders under the lower extremity of the frame, plate  $F$  being attached to the lower end of the frame. The latter is then lowered until the upper end of the pile enters the aperture in the plate and the latter rests upon the shoulder of the pile. When the entire weight of the frame and cylinder is upon the pile steam is then admitted into the steam-chest  $I$ , which fills chamber  $K$ , and by its pressure-disk  $K^1$  is raised, which lifts the cut-off valve  $L$ , opening port  $e$ , and the steam is admitted into cylinder  $G$  under the piston  $H$ , and by its pressure said piston is raised, carrying with it the hammer, and as said hammer has reached the limit of its upward movement cam  $G^2$  is brought in contact with pulley  $r$  of lever  $p$ , tilting said lever upward, imparting a downward movement to arm  $p'$ , which forces connecting-rod  $M$  downward, consequently the cut-off valve  $L$ , which brings the concavity  $f$  of said valve against port  $e$ , thus

allowing the steam to escape from said cylinder through port  $e'$ , and the hammer falls. Pawl  $h$  of shaft  $R$  enters the mortise in said connecting-rod as the same is forced downward, holding the same in a fixed position until the hammer reaches the pile, and by its concussion lever  $H^2$  is tilted downward, bringing its end against lever  $n$ , moving the same outward, which releases the pawl  $h$  from the connecting-rod, and said cut-off valve is again raised by the pressure of steam against the disk  $K^1$ , opening port  $e$ , and the steam enters the cylinder, and the hammer is again raised.

I am aware that steam pile-drivers have been previously used in which the hammer was lifted by the direct action of the steam. But with such the plate guiding the pile is permanently attached to the hammer-frame; consequently the lateral strain of the pile is communicated direct to the hammer-frame. But in my invention the plate is loosely attached to the hammer-frame, and is capable of a lateral movement independent of the frame; consequently the lateral strain of the pile is entirely relieved from the frame guiding the hammer, and is communicated direct to the leaders, the pile being between the leaders, and secured in position by the plate. With my invention the pile can be driven below the lower extremity of the leaders, for the arrangement of the frame guiding the hammer and the grooved cylinder is such as to allow the frame to extend below the leaders when found necessary, and still retain its original vertical position, which cannot be done with the pile-drivers now in use.

Having thus described my invention, I claim—

1. The detachable grooved plate  $F$ , loosely attached to the frame  $E$ , in combination with the grooved hammer  $A^2$ , arranged substantially as and for the purpose specified.

2. In combination with lever  $p'$ , valve-stem  $M$ , coupling-rod  $M'$ , and coupling  $P$ , the adjustable boxes  $t t$  and bolt  $r'$ , all operating as specified.

THOMAS T. LOOMIS.

Witnesses:

N. H. SHERBURNE,  
MARLAND L. PERKINS.