

A. H. SOUTHWICK.

Wind-Mill.

No. 160,794.

Patented March 16, 1875.

Fig. 1.

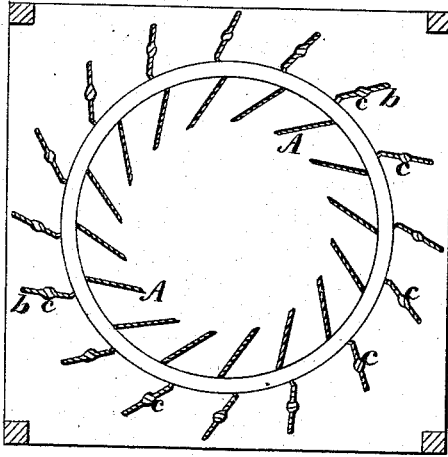

Fig. 2.

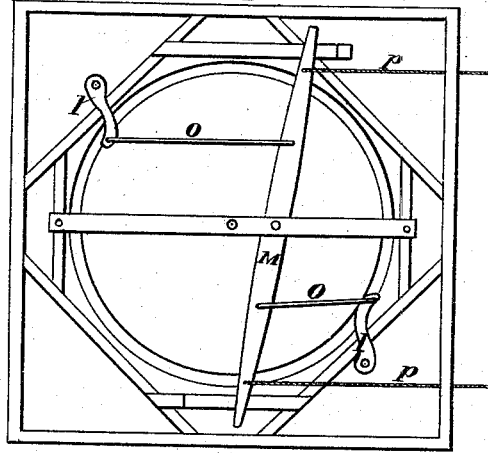

Fig. 3.

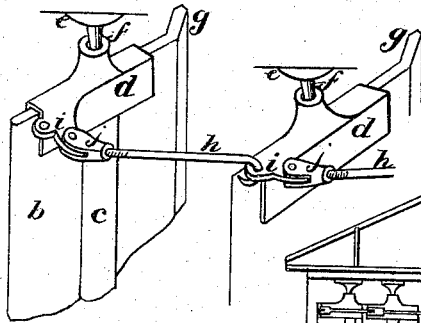

Fig. 5.

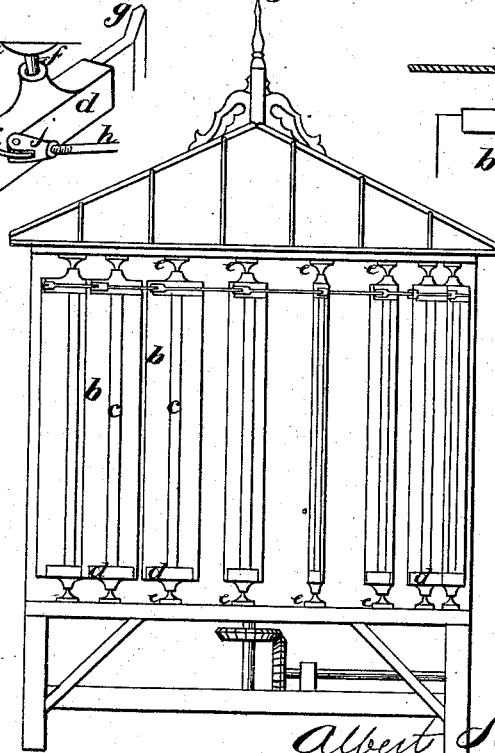
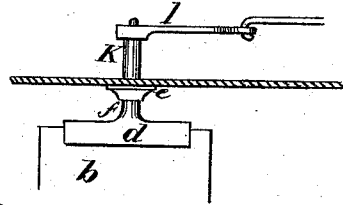

Fig. 4.



Witnesses
Geo. H. Strong
Jno. L. Burke

Inventor

Albert N. Southwick
by Dewey & Co
attys

UNITED STATES PATENT OFFICE.

ALBERT H. SOUTHWICK, OF SAN FRANCISCO, CALIFORNIA.

IMPROVEMENT IN WINDMILLS.

Specification forming part of Letters Patent No. **160,794**, dated March 16, 1875; application filed February 2, 1875.

To all whom it may concern:

Be it known that I, ALBERT H. SOUTHWICK, of San Francisco city and county, State of California, have invented Improvements in Windmills; and I do hereby declare the following description and accompanying drawings are sufficient to enable any person skilled in the art or science to which it most nearly appertains to make and use my said invention or improvement without further invention or experiment.

My invention relates to improvements upon the windmill which is known as the Dexter mill, and for which Letters Patent were issued to me on the 31st day of March, 1868.

My present improvement relates to the construction of and arrangement for operating the shuttles by which the wind force is admitted, regulated, and cut off entirely when desired from the wind-wheel.

In order to describe my improvements so that others will be able to understand their nature and arrangement, reference is had to the accompanying drawing forming a part of this specification, in which—

Figure 1 is a horizontal section of the mill. Fig. 2 is a plan, looking down upon the ceiling above the wheel. Figs. 3 and 4 are enlarged details of parts of my mill. Fig. 5 is a side elevation of the mill.

Let A represent the horizontal wind-wheel, which is mounted inside of a suitable frame or housing, as represented. This wheel is surrounded by a series of overlapping shutters, *b*, which are mounted on suitable bearings, and are so connected together that they can be simultaneously and correspondingly opened and closed, for the purpose of regulating the speed of the wheel by gaging the quantity of wind admitted to it. The shutters, if properly constructed and applied, will serve to regulate the speed of the wheel without any other governor. I, therefore, in constructing the shutters, secure longitudinally along the middle line, and upon each side of each shutter a rib or batten, *c*, which will prevent it from warping, and to each end of the shutter I secure a metal shoe or binding, *d*, which will also aid in keeping it from getting out of shape, and therefore preserve its easy movement in its bearings. The bearings of the shutters I con-

struct of metal by securing a metal button, *e*, to the frame above and below the middle line of each shutter. These buttons have each a central pin, which enters a socket in the shoe *d*, as shown.

It will thus be seen that it will be impossible for the shutters to bind and become stiff in their bearings by warping, as they are bound and braced in all directions.

The inner or overlapped edge *g* of each shutter I make angular, as shown, so that when the shutters are closed the angular edge will fit closely against the inner outside edge of the next shutter, and thus make a tight joint. This angular edge *g* will also project inside of the plane of the shutter, and thus form a wing, which will receive the force of the wind as it passes between the shutters. Therefore, when the wind increases in force, its action upon this wing will tend to close the shutters in proportion to the wind pressure. A counterbalancing weight could be employed to haul the shutters open again as the force of the wind diminishes; but this I have not shown, as it can be variously applied. To attach the end of the rods *h*, which connect the shutters together to the arm *i* of one of the shutters, I employ a nut, *j*, into which one end of the rods are screwed, so that the lengths of the rods can be adjusted readily after they have been secured in place, thus saving a considerable time in adjusting the shutters. To provide for the simultaneous adjustment of the shutters, I extend the upper gudgeon of two opposite shutters through the ceiling of the frame or housing, so as to provide a projecting end, *K*, above the ceiling, to which a crank-arm, *l*, is secured. A lever, *M*, extends across above the wind-wheel A, and is pivoted at its middle, so as to provide two arms. One end or arm of this lever is connected with each of the crank-arms *l* by a connecting-rod, *o*, so that by moving the lever *M* about its center or pivot, the shutters are simultaneously opened and closed. A cord, *p*, is attached to each end of the lever *M*, and extends down outside of the frame to within easy reach of the person standing on the platform of the mill. By drawing upon these cords, the lever is shifted and the shutters operated. As the cranks *l* of the opposite gudgeons are con-

nected with the lever M on opposite sides of its pivot or center, and the operating cords are applied in a similar manner, the shutter can be turned with precision, and held at any desired position.

I thus greatly improve the Dexter mill by obviating the faults which it has heretofore possessed.

Having thus described my invention or improvement, what I claim, and desire to secure by Letters Patent, is—

1. The shutters *b*, having the metal binding or shoe *d* secured to each end, substantially as and for the purpose described.

2. The overlapping shutters *b*, having their inner or overlapped edges *g* bent, or otherwise constructed at an angle to the shutter, substantially as and for the purpose described.

3. The nut *j*, and connecting-rods *h*, in combination with the shutters *b* and arms *i*, substantially as and for the purpose above described.

4. The centrally-pivoted lever M, having its ends connected by rods *o* with the crank-arms *l*, which are secured to the upper end of the projecting gudgeons K, in combination with the cords *p*, substantially as and for the purpose described.

In witness whereof I hereunto set my hand and seal.

ALBERT H. SOUTHWICK. [L. s.]

Witnesses:

J. L. BOONE,

C. M. RICHARDSON.

1.25
words.