

J. BYINGTON.

Grate.

No. 160,813.

Patented March 16, 1875.

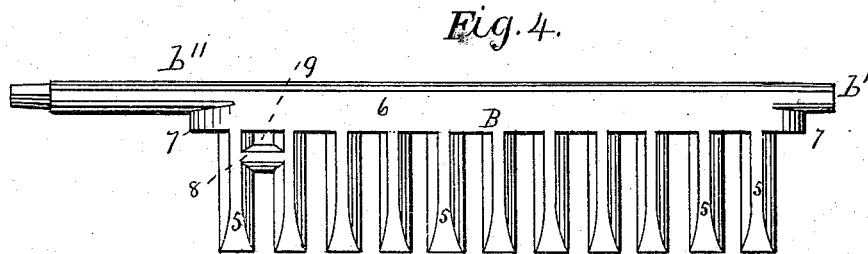
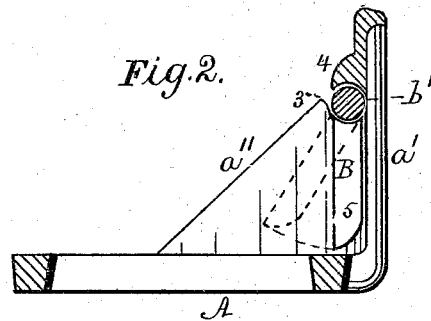
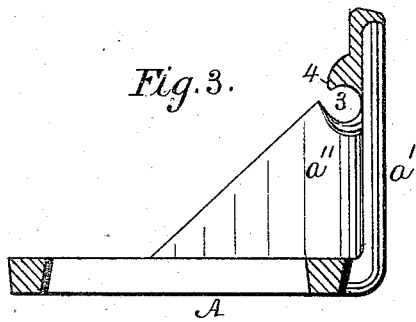
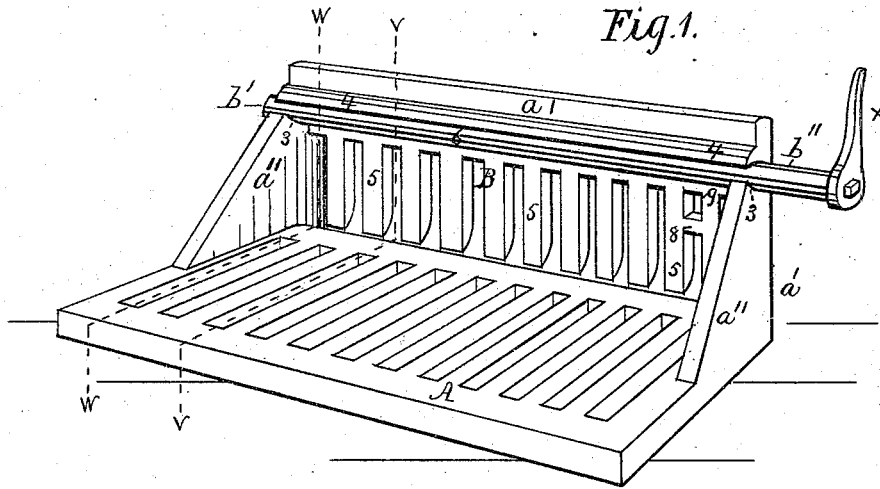

WITNESSES:

Benj. Morrison
Wm. H. Morrison.

INVENTOR:

Justin Byington

UNITED STATES PATENT OFFICE.

JUSTIN BYINGTON, OF WILMINGTON, DELAWARE.

IMPROVEMENT IN GRATES.

Specification forming part of Letters Patent No. **160,813**, dated March 16, 1875; application filed February 17, 1875.

To all whom it may concern:

Be it known that I, JUSTIN BYINGTON, of Wilmington, in the county of New Castle and State of Delaware, have invented an Improvement in Grates for Stoves and Ranges, of which the following is a specification:

The object of my improvement is to afford greater facility and simplicity in the operation of removing cinders and stones from the bottom of a stove or range grate without causing the incandescent fuel from falling during the said operation; and my invention consists of a stationary horizontal bottom grate and a vertical front frame, cast in one piece, in which a front grate is suspended, so as to be easily swung inward by means of a small hand-lever, and held so as to support the incandescent fuel while the cinders and stones are being withdrawn through the opening left between the front edge of the bottom grate and the lower ends of the inwardly-turned front grate, as will be hereinafter more fully explained, with reference to the accompanying drawing, in which—

Figure 1 is a perspective view of my said improved grate, as seen from the inner side of the same. Fig. 2 is a vertical transverse section of Fig. 1 cut in the dotted line *v v*. Fig. 3 is a vertical transverse section of the stationary portion cut in the dotted line *w w* of Fig. 1. Fig. 4 is a front elevation of the swinging portion of my said improved grate detached from the stationary portion.

The stationary portion A of the said grate is cast with a vertical open frame, *a'*, in front as one piece, the said frame *a'* being strengthened in its connection with A by the rear sloping portions *a'' a''*, which have also respective open bearings 3 3 for the two journals *b' b''* of the swinging portion B of the said grate. The under edge of the upper portion of the frame *a'* is curved transversely along its whole length, so as to correspond and be in line with the top curves of the respective bearings 3 3, the said under edge projecting on the inner side, as shown by 4 4 in Figs. 1, 2, 3. The swinging portion B of said grate consists of a single piece of casting having a series of grate-bars, 5 5, projecting in the same plane from

the under side of a single bar, 6, the two ends of which project and form the two journals *b' b''*, upon which the said portion B swings and rests in the open bearings 3 3, when the said portion B is operated, as will be explained.

The lower ends of the series of bars 5 5 are free from each other, as shown in Figs. 1 and 4; and when the said portion B is suspended in the bearings 3 3 the lower ends of the bars 5 5 just clear the upper surface of the front part of A, (see Figs. 1 and 2,) filling also the whole open front of A, and the rounded upper edge of 6 fitting closely under the curved under edge of 4. The said swinging portion B is prevented from being pressed outward in front by means of the two small projections 7 7 at the respective ends of B coming in contact with the respective rear sides of the end parts of B. Two of the grate-bars 5 are connected, also, by a cross-bar, 8, so as to leave a hole, 9, for the introduction of the smaller end of a curved hand-lever, *x*, to be used for turning the part B inward and upward on its journals into the raised position. (See Fig. 2.) The longer journal *b''* is elongated for the purpose of applying the curved hand-lever *x* in such cases as may render such elongation desirable. (See Fig. 1.)

The lower ends of the bars 5 5 of the part B are curved from the front downward to the rear sides, for the purpose of allowing them to be freely moved backward.

The whole grate is intended to be placed between the two ordinary end bricks and against the ordinary back brick (not shown) in the usual well-known manner, and consequently the two sloping parts, *a'' a''*, of A will prevent any cinders from adhering and obstructing the free swinging motions required in operating the part A, which is one of the objects obtained by the said parts *a''*.

It will be understood without any further description that the part B can be readily turned on its journals inward and upward in the direction indicated in Fig. 2, and thus produce the desired open space in front for separating and withdrawing the cinders and stones, and that the incandescent fuel above the said upturned part B can be securely

prevented from falling while the said position of B is maintained by the operator's hand resting upon the hand-lever *x*, by means of which the said upturning of B has been effected.

I claim as my invention—

The combination, with the stationary horizontal grate A and open vertical front frame

a' and sides *a'' a''*, of the inwardly-swinging front grate B, substantially as hereinbefore set forth and described.

JUSTIN BYINGTON.

Witnesses:

BENJ. MORISON,
WM. H. MORISON.