

C. D. SHRADER.  
Harvester.

No. 160,845.

Patented March 16, 1875.

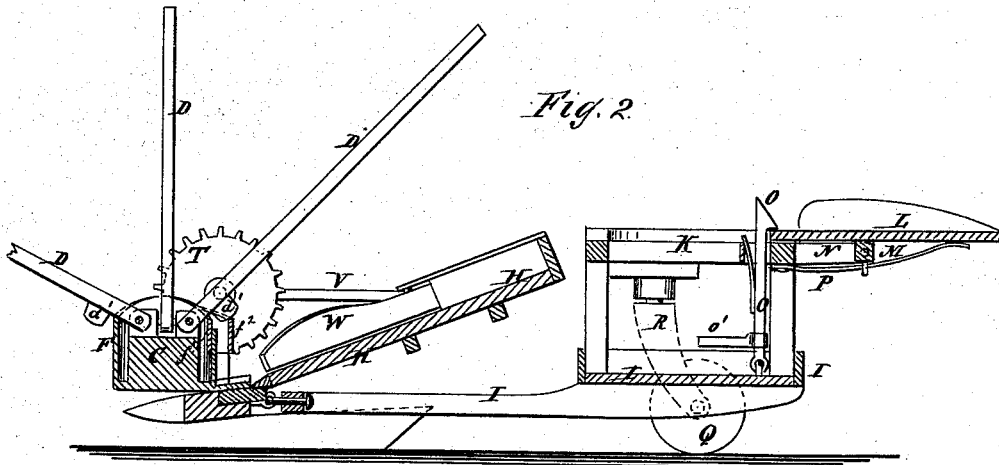

Fig. 2.

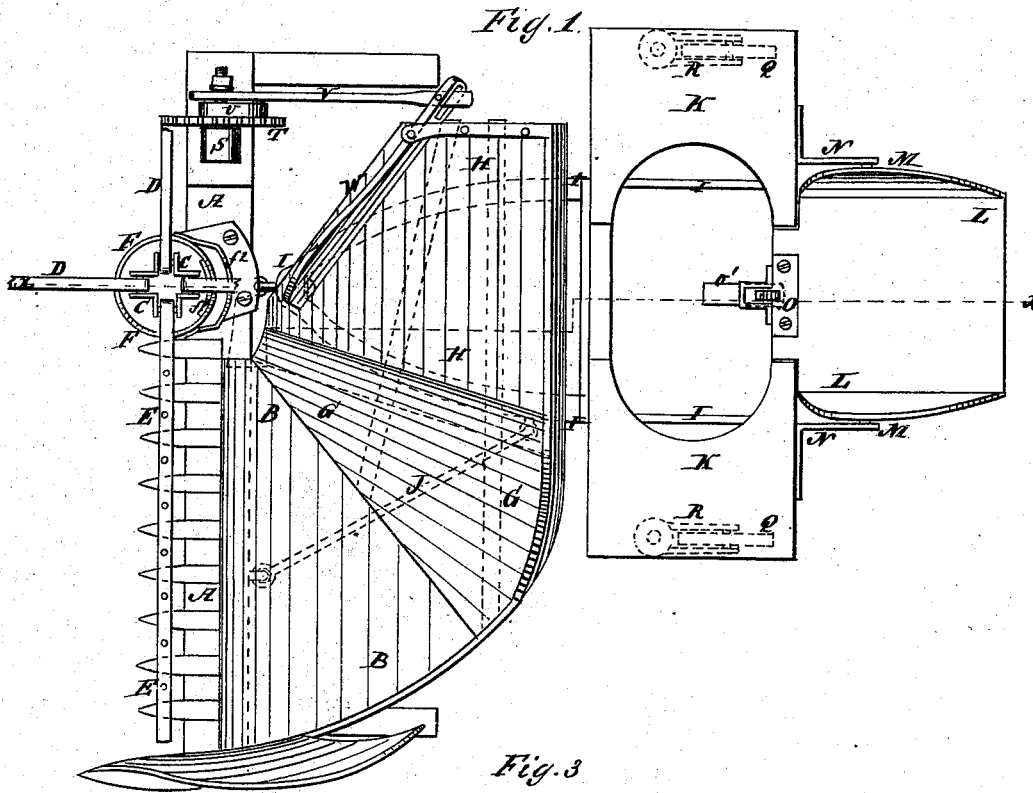
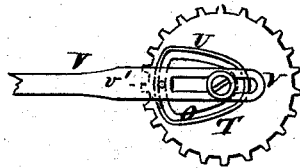

Fig. 1.

Fig. 3.

WITNESSES:

*E. Wolff*  
*A. F. Terry*



INVENTOR:

*Chas. D. Shrader*

BY

*mmu*

ATTORNEYS.

# UNITED STATES PATENT OFFICE.

CHARLES D. SHRADER, OF LANCASTER, WISCONSIN, ASSIGNOR TO HIMSELF  
AND ALLEN R. BUSHNELL, OF SAME PLACE.

## IMPROVEMENT IN HARVESTERS.

Specification forming part of Letters Patent No. **160,845**, dated March 16, 1875; application filed  
December 28, 1874.

*To all whom it may concern:*

Be it known that I, CHARLES D. SHRADER, of Lancaster, in the county of Grant and State of Wisconsin, have invented a new and useful Improvement in Binder Attachment for Harvesters, of which the following is a specification:

Figure 1 is a top view of a harvester-platform to which my improvement has been applied. Fig. 2 is a detail vertical section of the same, taken through the line *x x*, Fig. 1. Fig. 3 is a detail side view of the cam and connecting-bar.

Similar letters of reference indicate corresponding parts.

My invention relates to an attachment for the platforms of grain-harvesters, for the purpose of facilitating the work of the binders, as hereinafter described.

A represents the cutter-bar, and B the platform, of a harvester. C is a revolving post or stud, to which are hinged the beaters D and rake E. The post C is surrounded by a cam, F, which is so formed as to raise the beaters and rake at the rear edge of the platform B, and lower them into proper position to sweep the standing grain against the cutters, and carry the cut grain up the platform. *f*<sup>1</sup> is a detachable section of a cam, which guides the rake to cause it to pass up the platform. *f*<sup>2</sup> is a section of a cam, placed upon the outside or inside of the main cam F, and which is designed to raise the beaters out of the way of the binders. *d' d'* are projections attached to the under side of the beaters D, to come in contact with the cams *f*<sup>2</sup>, and thus raise the beaters out of the way of the binders. G is an inclined portion of the platform, and H the table from which the grain is taken by the binders standing on platform I. The latter is connected to the finger-bar by a hinge, and also a brace-rod, J. K is the binders' table, having a hole or opening, in the center of which the binders stand. The bound bundles are laid upon the table L, attached to a cross-bar, M, by which it is hinged to arms N of table K. The table L is held in place, when raised into a horizontal position, by a spring-catch, O, having foot-piece O'. When the table L is tilted the spring P aids in restoring it to the former position. The weight of the binders' platform I and its attachments is supported and, as it were, balanced by two

wheels, Q, the standards R of which are swiveled to the end parts of the said table. To the cutter-bar A, or to some other convenient part of the frame-work of the machine, is attached a short standard, S, to the side of the upper end of which is pivoted a chain or gear wheel, T, which receives motion from the driving mechanism of the harvester, and to the side of which is attached, or in it is formed, a cam-groove, U, which receives a pin, *v'*, attached to the side of a connecting-bar, V, so that the said bar V may receive motion from the revolution of the wheel T. The end of the connecting-bar V is slotted longitudinally to receive the journal of the wheel T, so that the connecting-bar V can move back and forth only in a horizontal line. The rear end of the connecting-bar V is pivoted to a bar or sweep, W, which is hinged to the outer forward corner of the receiving-table H, so that the forward movement of the bar V may force the bar or sweep W back to compress the gavel, and thus enable it to be more readily removed by the binder, and the rearward movement of the bar V may force the sweep W forward to leave the table H unobstructed to receive the next gavel. The cam-groove U is so formed that the sweep W, when forced back to compress the gavel, may remain stationary during half a revolution or more of the wheel T, so that the binders may have time to remove the said gavel conveniently, and may then be moved forward as the rake E is passing up the inclined platform G, to leave the table H unobstructed to receive the next gavel.

I do not claim, broadly, a sweep for gathering or compressing the gavels upon a harvester-platform.

Having thus described my invention, I claim as new and desire to secure by Letters Patent—

The combination of the sweep W and connecting-rod V, provided with a slot and pin, the wheel T, and cam U, having the form described, whereby the sweep is operated to compress the gavel against the rear side of the platform, as set forth.

CHARLES D. SHRADER.

Witnesses:

JOHN G. CLARK,  
E. E. BARSTOW.