

R. F. BURNHAM & W. F. STRONG.
Signal-Light for Railroad-Cars.

No. 160,871.

Patented March 16, 1875.

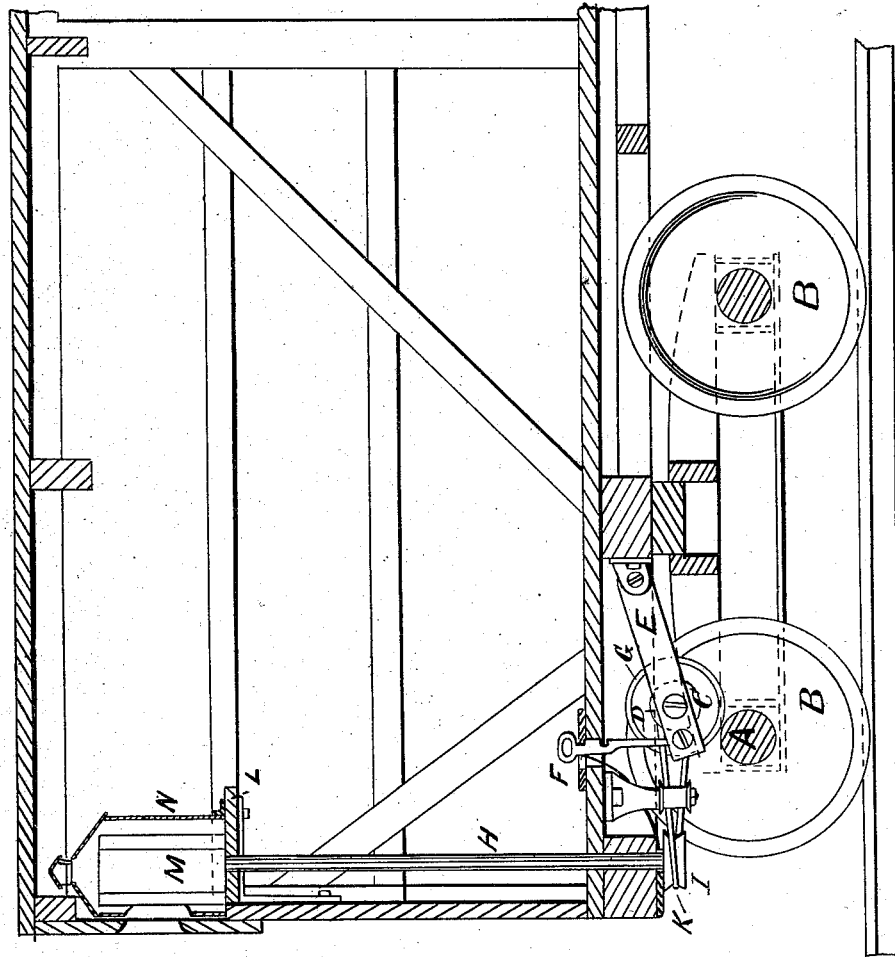

Witnesses
B. C. Pole
Albin H. Parris

Inventors
Robert F. Burnham &
William F. Strong by
C. S. Whitman
attorney

UNITED STATES PATENT OFFICE.

ROBERT F. BURNHAM AND WILLIAM F. STRONG, OF CHARLESTON, S. C.

IMPROVEMENT IN SIGNAL-LIGHTS FOR RAILROAD-CARS.

Specification forming part of Letters Patent No. **160,871**, dated March 16, 1875; application filed February 12, 1875.

To all whom it may concern:

Be it known that we, ROBERT F. BURNHAM and WILLIAM F. STRONG, both of Charleston, county of Charleston and State of South Carolina, have invented a Revolving Railroad Signal-Lamp. The following description, taken in connection with the accompanying plate of drawings hereinafter referred to, forms a full and exact specification, wherein are set forth the nature and principles of the invention, by which the same may be distinguished from others of a similar class, together with such parts thereof as are claimed as new and are desired to be secured by Letters Patent of the United States.

Our invention relates to that class of signals which are made use of on railway-cars; and the nature thereof consists in certain improvements in the details of the construction of the same, hereinafter shown and described.

In the accompanying plate of drawings, in which corresponding parts are designated by the same letters, Figure 1 is a longitudinal section through a railway-car having my improvements applied thereto.

In said drawings, B designates an ordinary car-wheel having an axle, A. C designates a friction-wheel having a rubber band, G, about the periphery thereof. The axle of said wheel has its bearings in the pivoted beam E, and is provided with a grooved pulley, D. The said beam is provided with a handle, F, which

is pivoted thereto, by means of which the said wheel C may be raised at will. Said handle is held in position by means of a catch or spring. I designates a grooved pulley connected by means of the band K, by which it is driven, with the pulley D. The said pulley I is attached to and rotates the upright shaft H, on the top of which is the lantern M, which may be of octagon shape and consists of four white and four red glasses. The said lantern is surrounded by a hood, N, so constructed that it can be readily lifted from the shelf L, to which it is attached, and it is provided with a door through which the lamp and reflector can be taken.

The operation of the mechanism will be obvious from the above description thereof.

Having thus described my invention, I claim and desire to secure by Letters Patent of the United States—

The combination of the axle A, wheel C, beam E, pulleys D and I, band K, handle F, shaft H, and lantern M, as and for the purposes described.

In testimony that we claim the foregoing we have hereunto set our hands.

ROBERT F. BURNHAM.
WILLIAM F. STRONG.

Witnesses:

JNO. REED,
PETER PARRY.