

R. S. CATHCART.
Mill-Spindle.

No. 160,874.

Patented March 16, 1875.

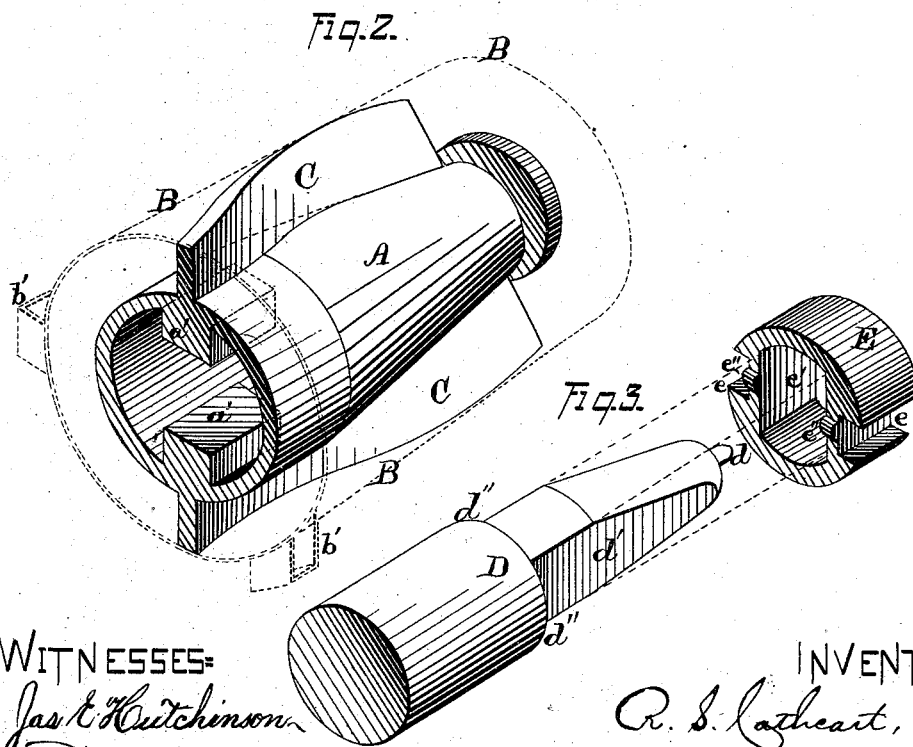
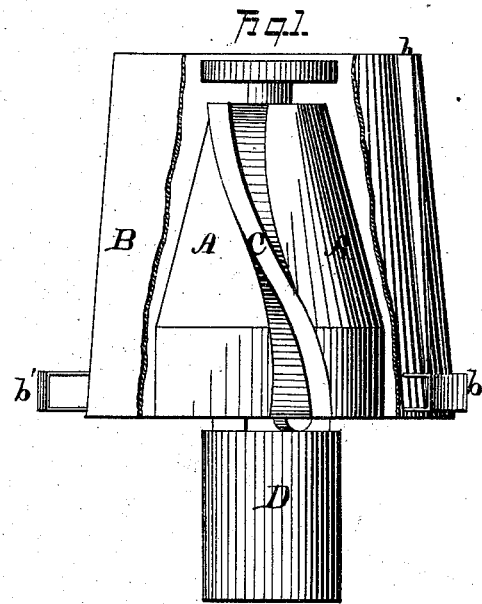

WITNESSES:
Jas. C. Hutchinson
John R. Young

INVENTOR
R. S. Cathcart, by
Prindle and Co. his Attys

R. S. CATHCART.
Mill-Spindle.

No. 160,874.

Patented March 16, 1875.

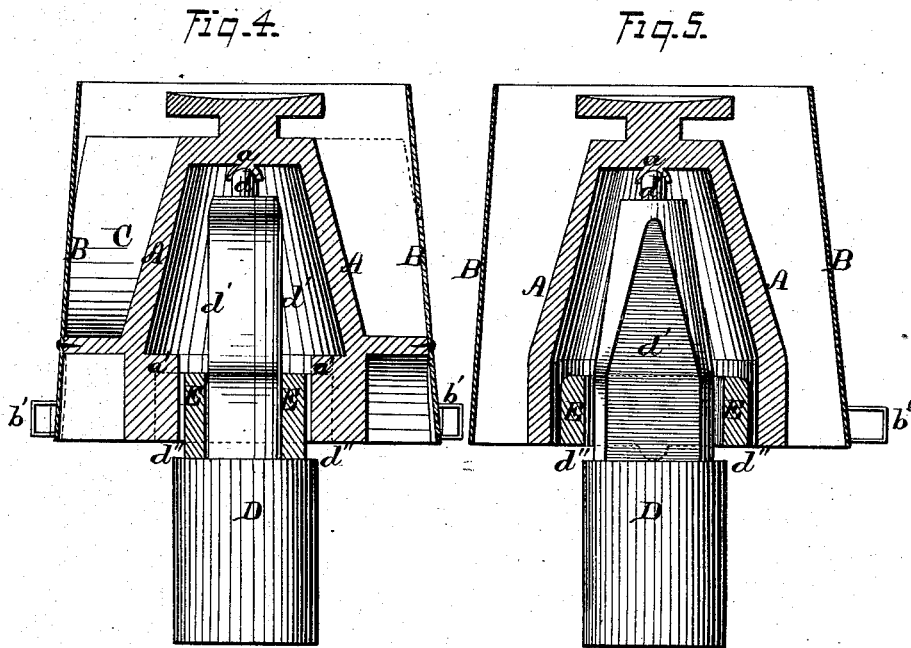

WITNESSES=

James Hutchinson
John R. Young

INVENTOR.

R. S. Cathcart, by
Prindle and Co. his Attys.

UNITED STATES PATENT OFFICE.

RODNEY S. CATHCART, OF CINCINNATI, OHIO, ASSIGNOR OF ONE-HALF HIS RIGHT TO STRAUB MILL COMPANY, OF SAME PLACE.

IMPROVEMENT IN MILL-SPINDLES.

Specification forming part of Letters Patent No. **160,874**, dated March 16, 1875; application filed January 28, 1875.

CASE B.

To all whom it may concern:

Be it known that I, RODNEY S. CATHCART, of Cincinnati, in the county of Hamilton and in the State of Ohio, have invented certain new and useful Improvements in Hanging Millstones; and do hereby declare that the following is a full, clear, and exact description thereof, reference being had to the accompanying drawings, making a part of this specification, in which—

Figure 1 is a side elevation of my improved device as arranged for use, a portion of the eye being broken away to show the interior. Fig. 2 is a perspective view of the rynd, the dotted lines showing the shape and position of the eye. Fig. 3 is a like view of the upper portion of the spindle and the lower side of the driver; and Figs. 4 and 5 are vertical central sections of said parts as combined, said sections being upon lines having relative angles of ninety degrees.

Letters of like name and kind refer to like parts in each of the figures.

The design of my invention is to enable an upper runner or millstone to more readily adjust itself to position, to prevent all liability to the clogging of its pivotal bearing, and to give increased strength and durability to the same, to which end it consists, principally, in the construction and combination of the balance-rynd, driver, and spindle, substantially as and for the purpose hereinafter shown. It consists, further, in the construction and combination of the spindle and driver, substantially as and for the purpose hereinafter set forth. It consists, finally, in the device as a whole, its several parts being constructed and combined to operate in the manner and for the purpose substantially as is hereinafter shown and described.

In the annexed drawings, A represents the balance-rynd, which has, preferably, a general conical form, and has its inner side hollowed out from beneath in substantially the same shape as its exterior. An eye, B, having the usual exterior shape, surrounds the rynd A, and is connected therewith by means of two or more radial flanges, C and C, which extend

between said parts, and vertically are formed upon spiral lines. Two or more radial vertical flanges, *b* and *b*, are formed upon the outer surface of the eye B for the purpose of increasing its strength, while, at suitable points upon its lower portion, are provided lugs *b'* for connecting said eye to or with a runner. Within the rynd A, at the upper end, is provided a semi-spherical socket, *a*, for the reception of a correspondingly-shaped teat, *a*, that is formed upon the upper end of the spindle D, which teat and socket sustain the weight of the runner, and permit the latter to oscillate sufficiently to cause its lower or grinding surface to adapt itself to the contiguous face of the lower or fixed stone. At opposite sides, and at the lower end of the cavity of the rynd, are two radial vertical lugs, *a'* and *a'*, which are loosely embraced by corresponding recesses *e* and *e*, that are formed within the edges of a driver, E, which driver has the form of a round disk, and is somewhat less in diameter than the lower end of said cavity, so as to be capable of lateral motion in a line with said lugs. The spindle D is flattened upon opposite sides, as seen in Fig. 3, from a point near its upper end downward somewhat below the bottom of the rynd, and such flattened portion is contained within a slot, *e'*, that is formed in and through the driver E, which slot is lengthened, so as to enable said driver to move laterally in a line having a right angle to the line of the recesses *e* and *e*. Two half-round lugs, *e''* and *e''*, formed upon the lower face of the driver E, with their axis in a line with the recesses *e* and *e*, rest upon the shoulders *d''* and *d''*, which form the lower ends of the faces *d'* and *d'*, and furnish bearings for said driver that enable the same to move to and fro upon said shoulders without unnecessary friction when rendered necessary by the oscillation of the runner.

The device described is used in the ordinary manner, and possesses the following-named advantages: First, it furnishes a pivotal connection, which enables the runner to oscillate freely as much as may be requisite without interfering with the spindle or its freedom of

motion. Second, it possesses unusual strength and durability, and is not liable to become de-
 ranged by wear or breakage. Third, the bear-
 ing and moving parts being entirely covered,
 no liability exists to interference with free op-
 eration by the falling or lodgment of grain.
 Fourth, the spiral shape of the flanges em-
 ployed for connecting the rynd and eye, beside
 affording additional strength to said parts, fa-
 cilitate the feeding of grain to the stone.

Having thus fully set forth the nature and
 merits of my invention, what I claim as new
 is—

1. In combination with the hollow balance-
 rynd A, provided with the radially inward-
 projecting lugs a' and a' , and with the spindle
 D, having the flattened portion d' , the driver
 E, fitted loosely upon said spindle, and pro-
 vided with recesses e and e , which embrace
 said lugs a' and a' , substantially as and for
 the purpose shown.

2. In combination with the spindle D, pro-
 vided with the flattened portions d' and d' ,
 and shoulders d'' and d'' , the driver E having
 a central slot, e' , which embraces said spindle
 and the lugs e'' and e'' that bear upon said
 shoulders, substantially as and for the pur-
 pose set forth.

3. The combination of the combined eye and
 rynd A, a , a' , and a' , B, C, and C, the spindle
 D, d , d' , and d'' , and the driver E, e , e' , and e'' ,
 substantially as and for the purpose specified.

In testimony that I claim the foregoing I
 have hereunto set my hand this 25th day of
 January, 1875.

R. S. CATHCART.

Witnesses:

J. W. BREWSTER,

A. C. ULRICH.