

R. S. CATHCART.  
Millstone-Bush.

No. 160,875.

Patented March 16, 1875.

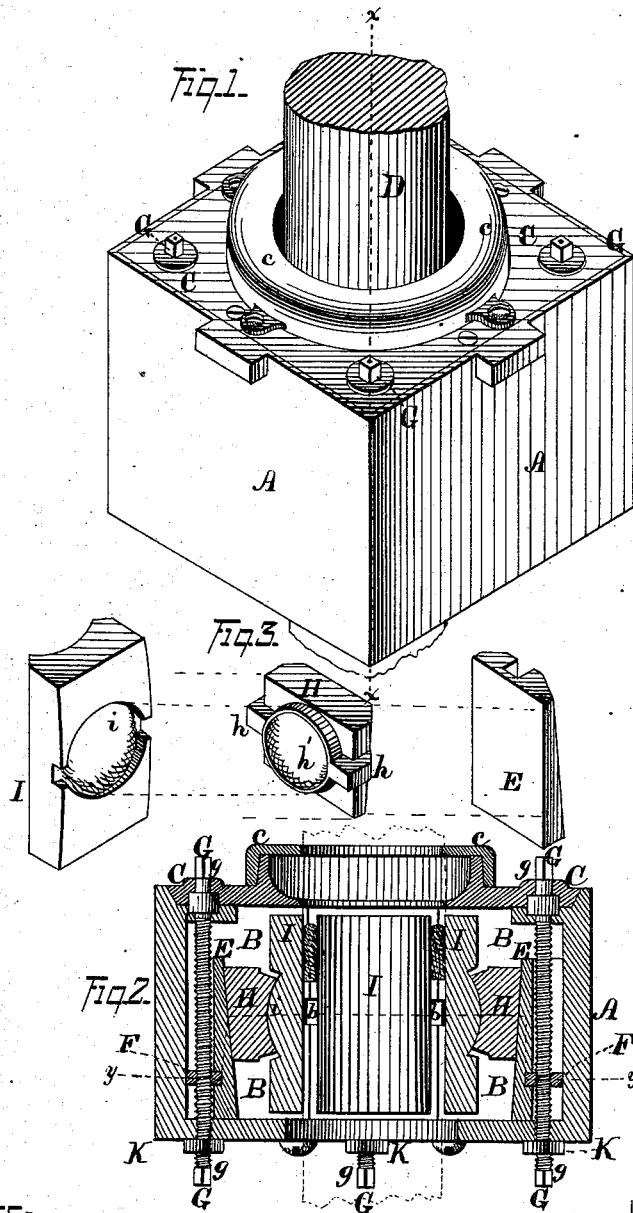

WITNESSES:  
*John E. Hutchinson*  
*John R. Young*

INVENTOR:  
*R. S. Cathcart*, by  
*Prindle and his Attys*

R. S. CATHCART.  
Millstone-Bush.

No. 160,875.

Patented March 16, 1875.

Fig. 4.

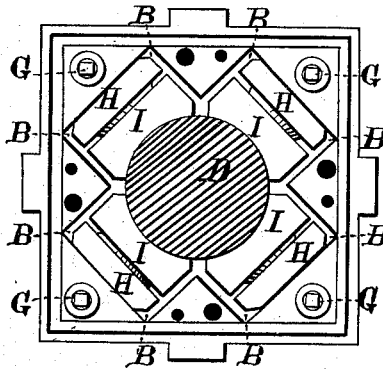
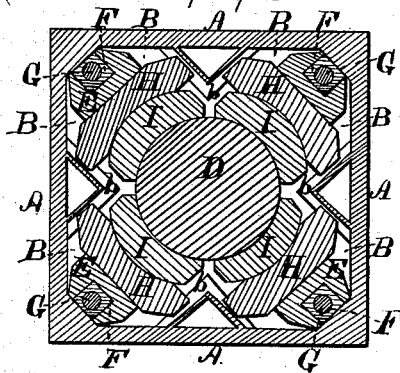

Fig. 5.



WITNESSES=

*Jas. E. Hutchinson.*  
*John R. Young.*

INVENTOR.

*R. S. Cathcart, by*  
*Prindle and Co. his Attys.*

# UNITED STATES PATENT OFFICE.

RODNEY S. CATHCART, OF CINCINNATI, OHIO, ASSIGNOR OF ONE-HALF HIS  
RIGHT TO STRAUB MILL COMPANY, OF SAME PLACE.

## IMPROVEMENT IN MILLSTONE-BUSHES.

Specification forming part of Letters Patent No. **160,875**, dated March 16, 1875; application filed  
January 28, 1875.

### CASE A.

*To all whom it may concern:*

Be it known that I, RODNEY S. CATHCART, of Cincinnati, in the county of Hamilton and in the State of Ohio, have invented certain new and useful Improvements in Hanging Millstones; and do hereby declare that the following is a full, clear, and exact description thereof, reference being had to the accompanying drawings making a part of this specification, in which—

Figure 1 is a perspective view of the exterior of my improved device. Fig. 2 is a vertical central section of the same upon line *xx* of Fig. 1; and Fig. 3 is a perspective view of one of the bearings, its follower, and adjusting-wedge. Fig. 4 is a plan view of the upper side of said device, its cover being removed; and Fig. 5 is a horizontal central section of the same.

Letters of like name and kind refer to like parts in each of the figures.

The design of my invention is to furnish, within the center of the lower or fixed stone of a grinding-mill, a bearing for the spindle of the upper stone or runner, which shall readily conform to any usual change of inclination of said spindle, and be adjustable horizontally, so as to enable said runner to be centered with reference to said lower stone; to which end it consists, principally, in the employment of a ball-and-socket bearing between each section of the box or spindle bearing and its follower, substantially as and for the purpose hereinafter specified.

It consists, further, in combining with each box-section a follower, having at its point of contact therewith a ball-and-socket bearing, and made radially adjustable toward or from the spindle, substantially as and for the purpose hereinafter shown.

It consists, finally, in the device as a whole, its several parts being constructed and combined to operate in the manner and for the purpose substantially as hereinafter set forth.

In the annexed drawings, A represents the casing or bush, which exteriorly has such size and shape as will enable it to fit the central opening of the lower or fixed stone of a mill,

and interiorly has a cavity, B, that horizontally has the form of a Greek cross, and is open at its upper side, and is inclosed, when in use, by means of a cover, C. The lower side and cover of the bush are each provided with a central opening, which corresponds to and receives the spindle D of the upper stone or runner. A stuffing-box, *e*, is provided around the opening in said cover, for the reception of the packing required for closing the space around said spindle, and preventing the passage of flour or grain to the interior of said bush. Within the outer end of each arm of the opening or cavity B is fitted a piece, E, which substantially fills the space laterally, and upon its front side inclines upward and outward, as seen in Fig. 2. A nut, F, secured to and projecting horizontally outward from the rear side of said wedge, receives a screw, G, which extends vertically through the upper and lower sides of the casing, and at one or both of its ends is journaled so that, while free to revolve, it is not capable of longitudinal motion. The projecting ends *g* and *g* of each screw G are squared, so as to enable them to be grasped and rotated by a wrench when the wedge-block E, which is considerably shorter than the space between the ends of the casing, will be raised or lowered longitudinally. Directly in front of each wedge E is placed a block, H, which is substantially square vertically, fills the space horizontally, and is sustained in position by means of two lugs, *h* and *h*, that project horizontally outward from opposite sides, and fit into corresponding horizontal grooves *b* and *b*, which are formed within the parallel sides of its space. The rear face of the block or follower H conforms to the inclination of the inner face of the wedge E, so as to have a firm bearing thereon, while its front vertical face is cut away at its upper and lower edges, so as to leave a disk, *h'*, that is circular, except where the lugs *h* and *h* intersect its sides. The face of said disk *h'* is concaved upon a circular line. In front of each follower H is placed a section, I, of a bearing, which section has a length nearly equal to the vertical dimensions of the cavity B, is plane upon its rear side,

and at its inner side is formed upon a line which corresponds to the circle of the spindle D. Within the rear outer face of the section I is formed a recess, *i*, that corresponds in general size and shape to the like features of the disk and lugs *h'* and *h* of the follower H, the bottom of said recess being convex, in order that it may have a bearing upon or within the concave face of said disk.

As thus constructed, the operation of parts is as follows: The bush A being secured within the lower or fixed stone, and the spindle D of the upper stone or runner in place within said bush, by turning the screws G and G the wedges E and E will be raised, and the followers H and H and the box-sections I and I forced inward until the latter have a bearing upon said spindle. Should the spindle be out of center with relation to the lower fixed stone, by lowering one wedge and raising that upon the opposite side, the sectional box, and consequently said spindle, may be moved in the direction desired.

When the spindle has been properly centered, and the necessary degree of closeness between the box-sections and said spindle secured, jam-nuts K and K are placed upon the lower ends of the screws G and G, and screwed upward until they bear firmly against the bush, and prevent all motion of said screws.

By means of the ball-and-socket bearings between the box-sections and followers, the former are allowed a certain degree of motion from a vertical line, in order to accommodate any practicable inclination of the spindle, or to accommodate themselves to the varying positions of the bearing-surface in case said spindle should not be perfectly straight.

The advantages obtained by the use of this invention are: First, it enables the box or bear-

ings to be tightened from either side of the stone with ease and safety. Second, it affords a convenient means whereby the runner may be centered or trammed. Third, the bearings for the spindle are afforded such freedom of motion from a vertical line as to enable them to conform automatically to any variations in the line of said spindle.

Having thus fully set forth the nature and merits of my invention, what I claim as new is—

1. The combination of the follower H, provided with the lugs *h* and *h* and concave disk *h'*, with the box-section I, having a recess, *i*, that corresponds to and receives said disk, said disk and recess forming a ball-and-socket bearing between said parts, substantially as and for the purpose specified.

2. In combination with each box-section I, provided upon its outer side with the convex recess *i*, the follower H, having upon its inner side the concave disk *h'*, and made radially adjustable toward or from the spindle, substantially as and for the purpose shown.

3. The casing A, provided with the cavity B and cover C, the wedges E and E, the nuts F and F, the screws G and G, the followers H, *h*, *h*, and *h'*, and the box-sections I *i*, all constructed as shown, and combined with each other, the spindle D, and the fixed stone of a grinding-mill, substantially as and for the purpose set forth.

In testimony that I claim the foregoing I have hereunto set my hand this 25th day of January, 1875.

R. S. CATHCART.

Witnesses:

J. W. BREWSTER,  
A. C. ULRICH.