

C. A. KING.
 Breech-Loading Fire-Arm.

No. 160,915.

Patented March 16, 1875.

fig. 1

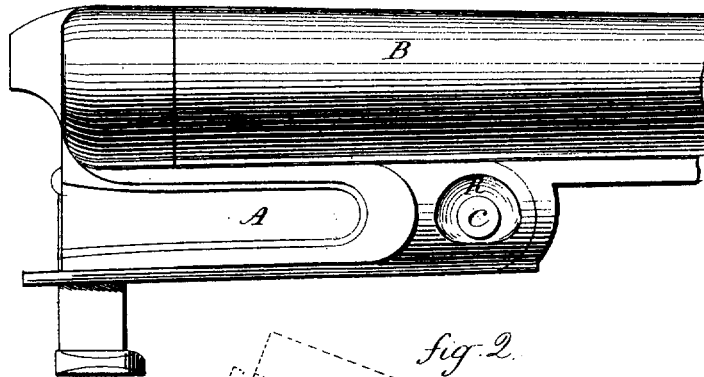

fig. 2

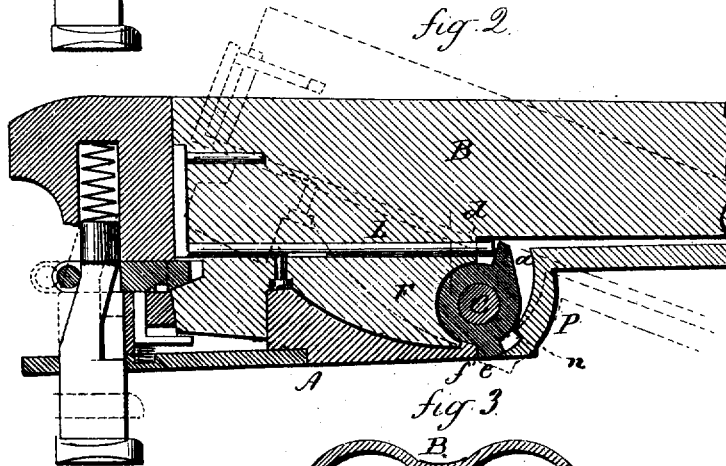

fig. 3

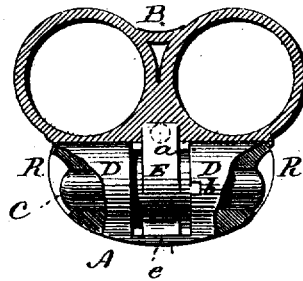
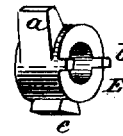

fig. 4



Witnesses.
J. H. Shumway
Jas. B. Earle

Chas. A. King
 By atty. Inventor
John B. Earle

UNITED STATES PATENT OFFICE.

CHARLES A. KING, OF MERIDEN, CONNECTICUT, ASSIGNOR, BY MESNE ASSIGNMENTS, TO CHARLES PARKER, OF SAME PLACE.

IMPROVEMENT IN BREECH-LOADING FIRE-ARMS.

Specification forming part of Letters Patent No. **160,915**, dated March 16, 1875; application filed February 5, 1875.

To all whom it may concern:

Be it known that I, CHARLES A. KING, of Meriden, in the county of New Haven and State of Connecticut, have invented new Breech-Loading Fire-Arms; and I do hereby declare the following, when taken in connection with the accompanying drawings and the letters of reference marked thereon, to be a full, clear, and exact description of the same, and which said drawings constitute part of this specification, and represent, in—

Figure 1, side view; Fig. 2, longitudinal section; Fig. 3, transverse section, showing the joint; Fig. 4, perspective view of the stop.

This invention relates to an improvement in that class of breech-loading fire-arms in which the barrel is hinged to the forward end of the frame, and arranged to tilt up at the breech.

The object of the invention is to take the strain from the pintle of the joint; and it consists, first, in the employment of a collar on the pintle, prevented from turning by connection with the frame, independent of the pintle, and with a projection or shoulder from said collar to form the stop; second, in the method of finishing the frame around the end of the pintle, as more fully hereinafter described.

A is the frame; B, the barrel or barrels, (here represented as two barrels,) hinged to the frame by a pivot, C, so as to tilt up at the breech, and secured in the closed position by any known or desirable device, that shown being the Miller patent, or better known as the "Parker gun," and no part of this invention. In the forward end of the frame, between the ears D D, the collar E is placed, it being bored out, so that the pintle C will pass through the ears D and the pintle to hold it between the ears. This collar is cylindrical in form on its back side, so that the lug F on the barrels, correspondingly shaped, will hook onto the back of the collar, as seen in Fig. 2, and substantially as it does in the usual construction. On the upper side of the collar is a projection, *a*, against which a shoulder, *d*, on the barrels will strike when the barrels are tilted, as denoted in broken lines, Fig. 2, thus

forming a stop to limit the extent of the opening. This projection *a* also serves to operate the extractor-rod L.

This is the usual construction. The collar is prevented from turning by its connection with the pintle, and the pintle prevented from turning by its connection with the frame. In such constructions the strain for the support of the open barrels comes entirely upon the pintle, except so far as it is relieved by a shoulder on the tang P striking the end of the recess in the frame. The tang closes upon the front surface of the collar to complete the hinge, in the usual manner. To take this strain from the pintle, a connection of some character is made between the collar and the frame to prevent the collar from turning. This is best done by the projection *b* on the side of the collar, and a corresponding recess in the side of the slot in the frame, as seen in Figs. 3 and 4, and as an additional preventive a projection, *e*, on the lower side of the collar bears against the end *f* of recess in the frame. By this construction the strain is almost entirely taken from the pintle, so that it may be left in perfectly cylindrical shape. The shoulder *n* on the tang P strikes the front of the projection *e*; at the same time the shoulder *d* on the barrel strikes the back side of the projection *a*.

In transverse section the frame at the pintle C is elliptical, and the ends of the pintle must be correspondingly finished; hence, if the pintle be not set in exactly the position it is then finished, its ends will not come flush with the surface of the frame, necessitating a spline on the pintle, or other device, to indicate the exact position it must occupy, or there is considerable difficulty in adjusting the pintle. To obviate this difficulty a spherical recess, R, is formed on each side of the frame at the pintle perforations, the axis of each recess in line with the axis of the pintle, as seen in Figs. 1 and 3, thus bringing the ends of the perforations into an annular plane, so that the ends of the pintle will come flush with such annular surface, whatever position (circumferentially) the pintle may be set in place.

Having thus fully described my invention, what I claim as new and useful, and desire to receive by Letters Patent, is—

1. In a fire-arm the barrel of which tilts up at the breech, the collar E, constructed with a connection to the frame other than the pintle, substantially as described.
2. In a fire-arm the barrel of which tilts

up at the breech, the recesses R in the frame around the pintle, substantially as and for the purpose described.

CHARLES A. KING.

Witnesses:

WILBUR F. PARKER,
CHARLES P. IVES.