

C. WASTE.
Hay-Press.

No. 160,976.

Patented March 16, 1875.

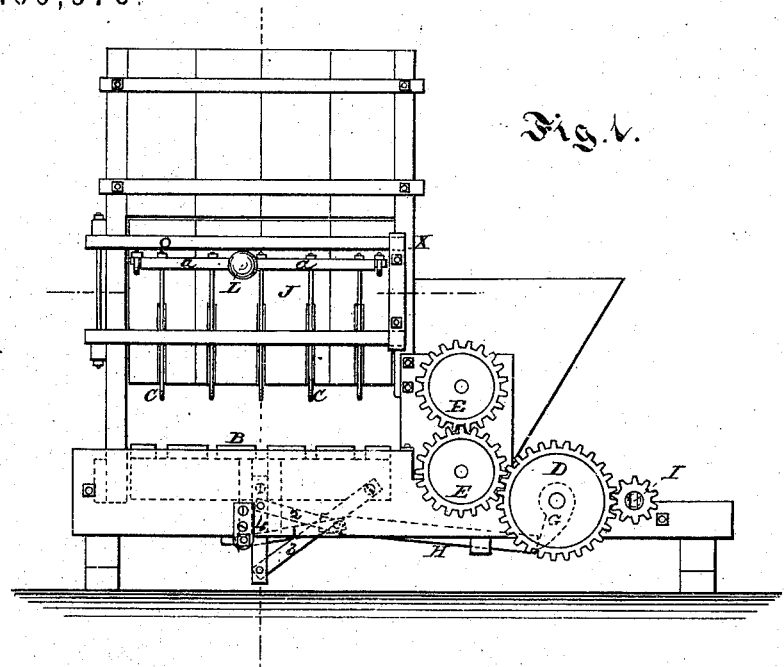

Fig. 1.

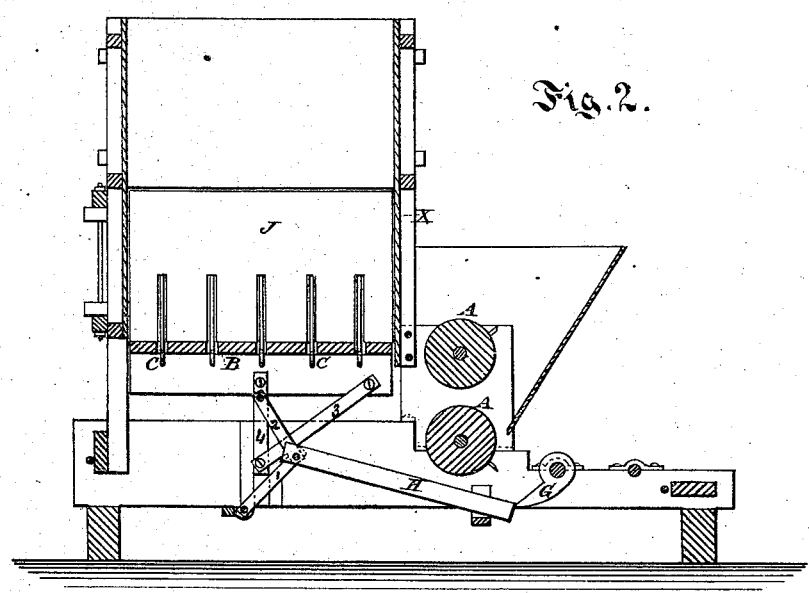

Fig. 2.

Witnesses:

Joseph Hoover
M. J. Conway

Inventor:

C. Waste

C. WASTE.
Hay-Press.

No. 160,976.

Patented March 16, 1875.

Fig. 3.

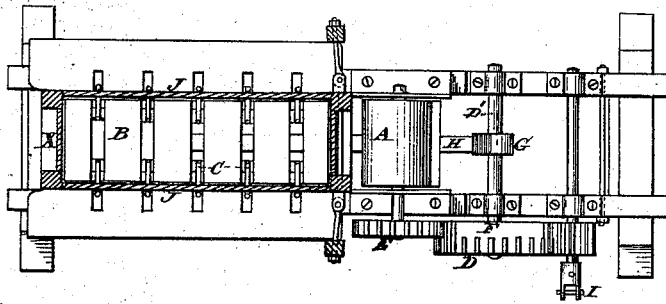

Fig. 4.

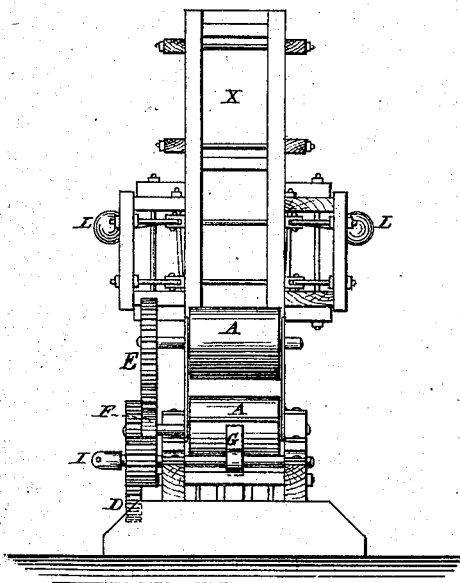
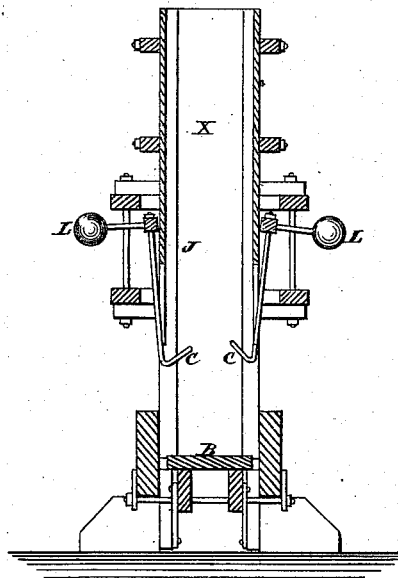

Fig. 5.



Witnesses:

Joseph Hoover
M. J. Conroy

Chas Waste Inventor.

UNITED STATES PATENT OFFICE.

CHARLES WASTE, OF GALESBURG, ILLINOIS.

IMPROVEMENT IN HAY-PRESSES.

Specification forming part of Letters Patent No. **160,976**, dated March 16, 1875; application filed January 5, 1875.

To all whom it may concern:

Be it known that I, CHARLES WASTE, of Galesburg, in the county of Knox and State of Illinois, have invented certain new and useful Improvements in Roller Hay-Presses; and I do hereby declare that the following is a full, clear, and exact description thereof, which will enable others skilled in the art to which it pertains to make and use the same, reference being had to the accompanying drawings, and to the letters of reference marked thereon, which form a part of this specification.

The nature of my invention consists in the construction, arrangement, and location of pressure-rollers, in their relation to a filler or follower operating within the press-box, so that the material pressed by the rollers is received upon the filler or follower in layers or sheets; also, in the construction and arrangement of a system of levers, attached to and operating upon such filler or follower, in such a manner as to force the sheets or layers of the material pressed within and upward into the press-box; also, in the construction and arrangement of self-adjusting hooks or holders that will yield when each sheet or layer is pressed upward within the press-box, and after such sheet or layer has been forced upward to its proper position such holders or hooks will return to their normal position, and retain such sheets or layers in position until a second layer or sheet presents itself; also, in the production of intermittent motion on the part of the rollers by the peculiar construction of the gear-wheel that operates and controls the movements of the wheels upon the roller-shafts, thereby allowing the filler or follower to perform its functions during the intermission of motion of such rollers.

In the drawings, Figure 1 is a side view of the hay-press, showing the gearing and its connections, and the filler or follower depressed and in position to receive the sheets or layers of hay or other material as they come from the rollers. Fig. 2 is a cross-section, showing the filler or follower in a raised position within the press-box, the levers, and arm operating the same. Fig. 3 is a top view, showing the construction of the driving-gear wheel, that produces intermittent motion at each of its revolutions. Fig. 4 is an end view, and Fig.

5 a vertical cross-section, showing the arrangement of the holders or hooks within the press-box, and the weight that retains them in position.

The rollers A A are placed at or near the lower end of the press-box, and may have adjusted upon them cutters, to aid in crushing and separating the hay, straw, or other material, as it passes through them. These rollers are operated by means of gear-wheels upon the ends of the shafts, upon which they are placed, as seen at E E; D being the driving-gear, and constructed in such a manner that a surface, F, (seen in Figs. 3 and 4,) has no cogs upon it; and at each revolution of the wheel D there is, for this reason, an intermittent motion of the rollers produced, as the driving-gear does not at that time engage with the gear-wheel E. At the point of time when this intermittent motion is produced the arm G (adjusted centrally upon the shaft to which the driving-gear D is secured) is forced against the arm H, as seen in dotted lines in Fig. 1, said arm H being connected with the follower or filler B by means of the levers 1 2, braces 3, and slide 4, as seen in Fig. 2, which shows one series of levers only, the same number being upon the opposite side and working in the same manner. It will thus be seen that when the intermittent motion of the rollers is produced, in the manner heretofore described, the filler or follower is being lifted, and deposits the layers or sheets of hay or other material within the press-box. J J are doors, hinged to each side of the hay-press, secured in any suitable manner, and O O braces, secured to such doors. To the upper brace O is hinged the bar a, and the holders or hooks C, attached to the same, as seen in Figs. 1 and 5. These holders or hooks are counterbalanced by means of the weight L, causing the said holders or hooks to be forced inward between spaces cut in the doors, so that the hooks shall always be within the press-box, and retaining the hay as it leaves the filler or follower, when the latter is withdrawn. These hooks or holders being bent upward offer no obstruction to the operation of the filler or follower, as when the hay comes in contact with them it forces them back, and when it reaches its proper position in the hay-press, the weight L causes

the said hooks to return to their position again, which position is below the hay upon the filler or follower, and between the spaces formed upon the same corresponding to the spaces within the doors J. In this manner the sheets or layers of hay or other material are held in position as they are delivered by the filler or follower, until the press is filled.

In the operation of my press, the rollers A A must first be so turned with reference to the gear-wheel D that the cogs upon D will be disengaged from the cogs upon the gear-wheel E upon the roller-shaft, when the sheet of hay is pushed just even with the inside of the press-box. As the cogs of D disengage from the gear-wheel E, the rollers cease rotating while the blank space formed on wheel D at F is passing wheel E, at which time the arm G engages with the bar or driver H, which, by means of its connection with the four short fulcrum-levers at its opposite end, forces the filler, with the sheet of hay upon it, upward and between the hooks or holders C C, where the hay is held, as before described. The arm G then is disengaged from the bar or driver H, allowing the filler to fall back into position before the cogs on wheel D again engage with those upon the wheel E. Wheel D then again engages wheel E, and turns it and the rollers one revolution while the filler is at rest, and thus the process is repeated alternately, the rollers delivering a sheet of hay and the filler pushing it within the grasp of the hooks or holders within the press until the press-box is filled with a bale of the desired weight. The press is driven by a tumbling-rod, from horse or other power connecting with the coupling I.

The holders C C being attached to the doors, are in a proper position when the doors are closed for filling the press in the manner described, and when the press is thus filled and the bale pressed and ready for baling, the doors are thrown open, carrying with them the holders C C, when the bale may be properly bound, and removed from the press.

The process of filling the press by means of

a filler or follower constructed substantially as herein described, and in connection with the rollers employed in the formation of layers or sheets, can be readily applied to a horizontal as well as vertical press, without changing the principle of the machine employed for that purpose.

A spring or springs may also be employed in connection with the holders C C, to retain them in the desired position for performing their specific functions, in lieu of the weight herein shown, and with like effect. The hay, straw, &c., can be fed to the rollers in the usual manner.

What I claim as my invention, and desire to secure by Letters Patent, is—

1. The rollers A A, gear-wheel D, having the smooth surface F upon its face or periphery, and gear-wheels E E, in combination with the follower or filler B and press-box X, in the manner and for the purpose herein set forth.

2. The combination of the driver H, with its connecting-levers 1 1 2 2, with the follower or filler B, and arm G, in the manner and for the purpose herein set forth.

3. The bar a, pivoted, as described, to the door-frame O, in combination with the holders C C and weighted lever L, in the manner and for the purpose herein set forth.

4. In a hay-baling press, the combination of the rollers A A, gear-wheel D, with its smooth surface F on its face or periphery, gear-wheels E E, attached to the shafts or axles of the rollers A A, arm G, secured centrally to the shaft or axle D', driver H, and levers 1 1 2 2, with the filler or follower B, in the manner and for the purpose herein set forth.

In testimony that I claim the foregoing as my own I affix my signature in presence of two witnesses.

CHARLES WASTE.

Witnesses:

JOSEPH HOOVER,
M. S. SMALLLEY.