

W. AIKEN.
Screw-Blank Feeder.

No. 160,990.

Patented March 23, 1875.

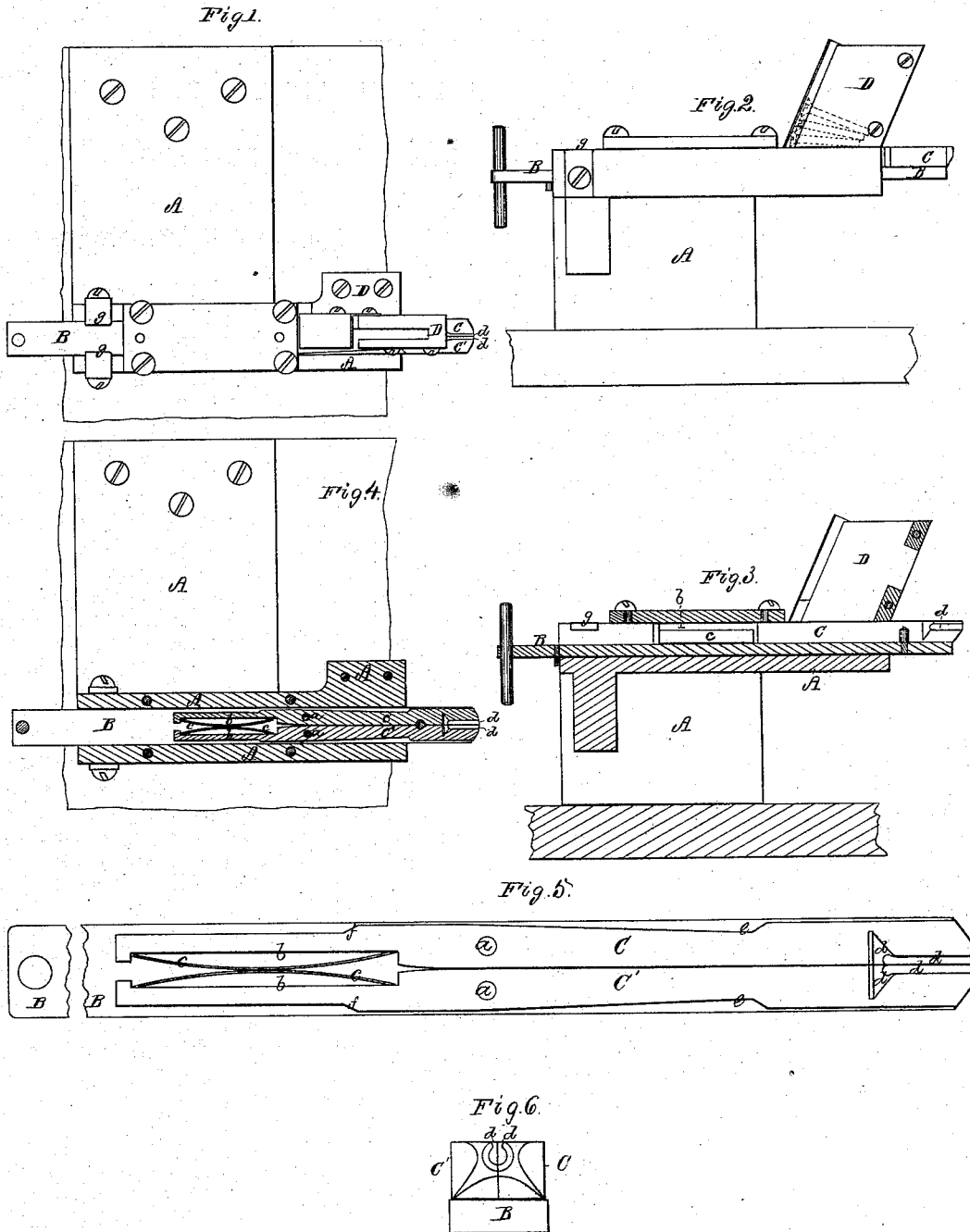

Witnesses.
S. N. Piper.
L. N. Spiller.

Walter Aiken.
by his attorney.
R. H. Cady.

UNITED STATES PATENT OFFICE.

WALTER AIKEN, OF FRANKLIN, NEW HAMPSHIRE.

IMPROVEMENT IN SCREW-BLANK FEEDERS.

Specification forming part of Letters Patent No. 160,990, dated March 23, 1875; application filed February 27, 1875.

To all whom it may concern:

Be it known that I, WALTER AIKEN, of Franklin, of the county of Merrimack and State of New Hampshire, have invented a new and useful improvement in machinery for feeding screw-blanks from a hopper to mechanisms for either threading, nicking, or otherwise treating them; and I do hereby declare the same to be fully described in the following specification and represented in the accompanying drawings, of which—

Figure 1 is a top view, Fig. 2 a side elevation, Fig. 3 a longitudinal and vertical section, and Fig. 4 a horizontal section, of one of my new feeders. Fig. 5 is a top view, and Fig. 6 a front-end view, of the carrier or slide-bar with its levers.

My invention relates to certain socketed and recessed levers, a slide-bar or carrier therefor, a bracket, and conductor, all as hereinafter explained.

In such drawings, A denotes a bracket, provided with a groove or channel, extending transversely through it to receive a slide-bar, B, and to guide it rectilinearly in its reciprocating longitudinal movements. To the upper surface of the said bar there are pivoted two jawed levers, C C', formed and arranged as shown, their fulcrums being represented at *a*. In recesses *b b*, made in the rear arms of said levers, are one or two bow or other proper springs, *c c*, the purpose of which is to close the jaws of the levers. At its front end each lever is furnished with a socket, *d*, open at top to receive the head and part of the shank of a screw-blank. Both levers are also notched on their sides, as shown at *e e*, in order to enable them to open apart far enough for the escape of a blank from them while being drawn out of their sockets. Over the levers there is arranged and fixed to the bracket an inclined

conductor, D, for holding the blanks one over the other, in manner as represented by dotted lines in Fig. 2, and also guiding them successively down to the levers. Furthermore, the two levers have inclined shoulders, as shown at *f f*, to operate with two cams or projections, *g g*, fixed to the bracket, and arranged as represented.

On drawing back the slide-bar B far enough the shoulders *f f* and the projections *g g* will force the rear arms of the jawed levers toward each other, and thereby cause the other or front arm to open apart a short distance, so as to enable a screw-blank at the bottom of the pile to fall into the sockets or jaws of the levers, which will close upon it immediately on the slide-bar being advanced. As the said bar with the levers may be moved forward, the blank will be forced from the conductor, to be caught at its shank by other jaws or mechanism, and held stationary while the springs *c c* readily admitting of the jaws opening and passing off the blank, as they may be drawn back.

I claim—

1. In combination with the grooved bracket A, the projections *g g* and the inclined conductor D, arranged as described, the slide-bar B, and the two levers C C', provided with the sockets *d d*, inclined shoulders *f f*, and operative spring or springs *c c*, all being constructed and applied substantially in manner and to operate as and for the purpose specified.

2. The movable levers C C', provided with the blank-sockets *d d*, spring-recesses *b b*, inclined shoulders *f f*, and the side notches *e e*, all arranged substantially as specified.

WALTER AIKEN.

Witnesses:

R. H. EDDY,
J. R. SNOW.