



Validation of the Thermal Metrology System for the AEM ALMA Antennas

Robert Laing (ESO)

[on behalf of many people at EIE, Microgate, ESO and JAO, particularly Pascal Martinez, Emanuela Ciattaglia, Francesco Rampini, Leonardo Ghedin]



Absolute pointing tests

Specification 2 arcsec rms

- Grid of measurements across the sky
 - Fit parameterized model with geometrical and empirical terms (TPOINT)
 - Monitor stability
- Optical Pointing Telescope
 - Mounted on back-up structure; does not test full antenna; fine for steel parts
 - Measurements are rapid
 - Accurate to a few tenths of an arcsec; long-term stability needs extreme care
 - Used at OSF (3000m site) for antenna verification and acceptance
- Interferometric Pointing
 - Tests full antenna, including subreflector and receiver optics
 - Cross -scans, using one or more antennas as a reference
 - Bright quasars, usually 90 GHz



Pointing Model

- Geometrical terms
 - Encoder index errors in Elevation and Azimuth (IE, IA)
 - Collimation error in Azimuth (CA)
 - Axis non-perpendicularity (NPAE)
 - Azimuth axis tilts NS and EW (AN, AW)
- Empirical terms
 - Elevation flexure
 - Harmonics of Azimuth in Azimuth and Elevation (up to third order)
 - Small and very stable

All-sky Pointing - core model

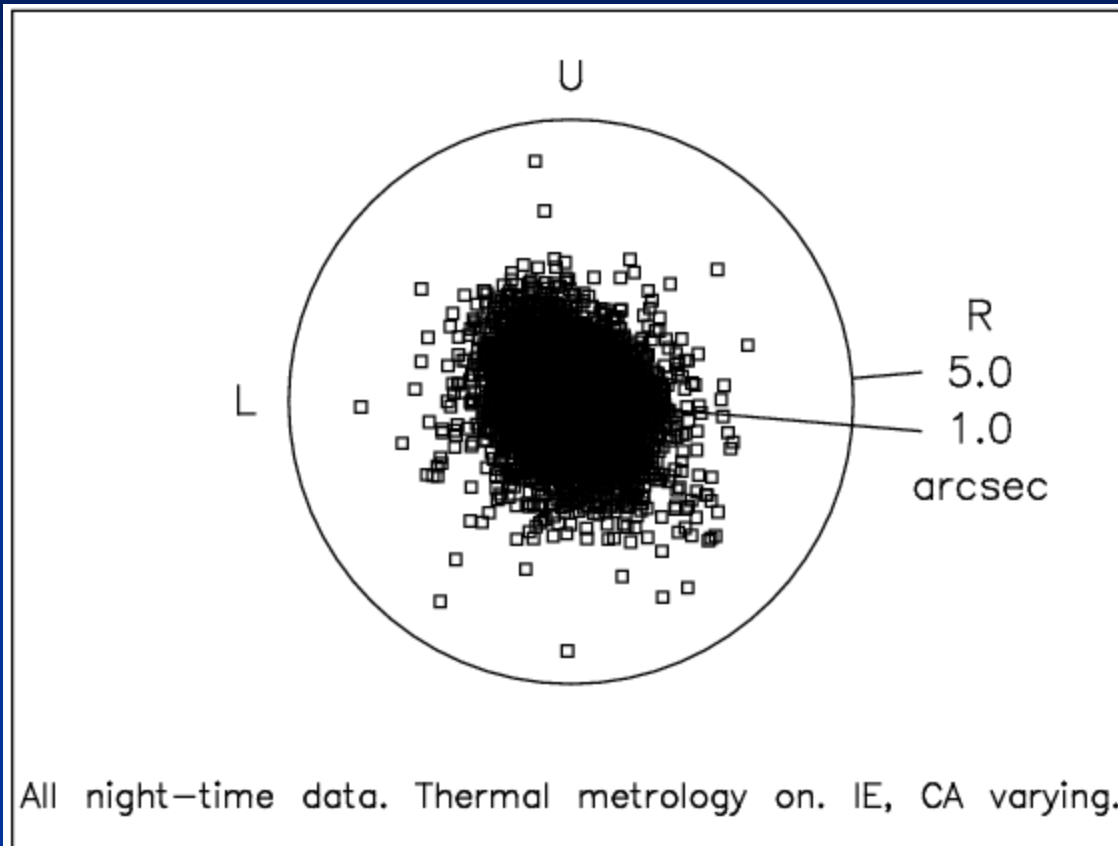

Residuals from
combined dataset
with collimation terms
varying

rms 1.00 arcsec

6274 measurements

Thermal metrology on

DA42

Residuals

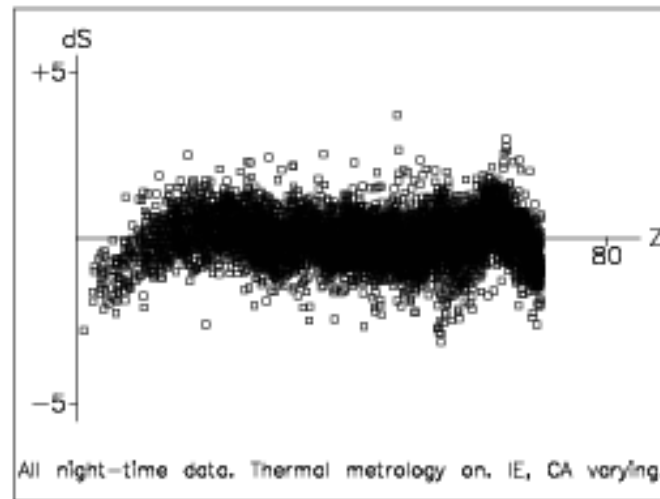
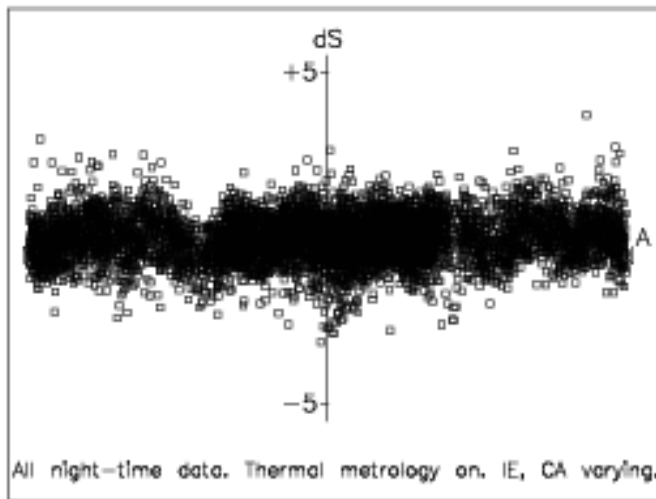
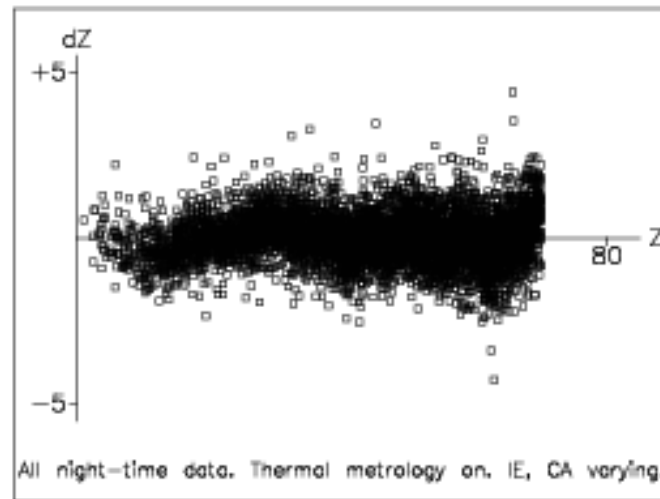
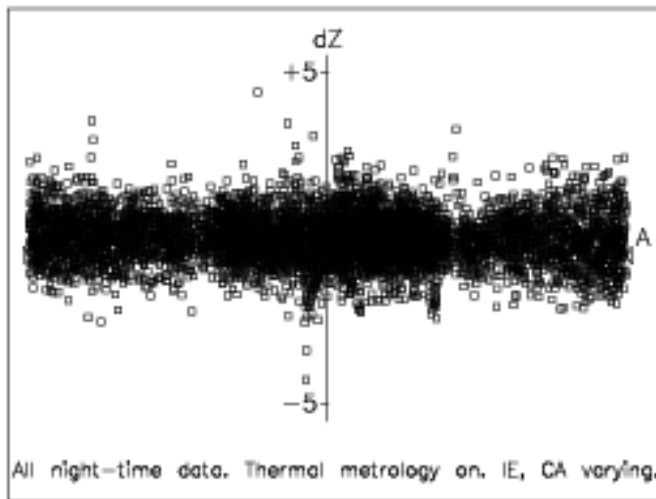

Elevation-dependent Residuals

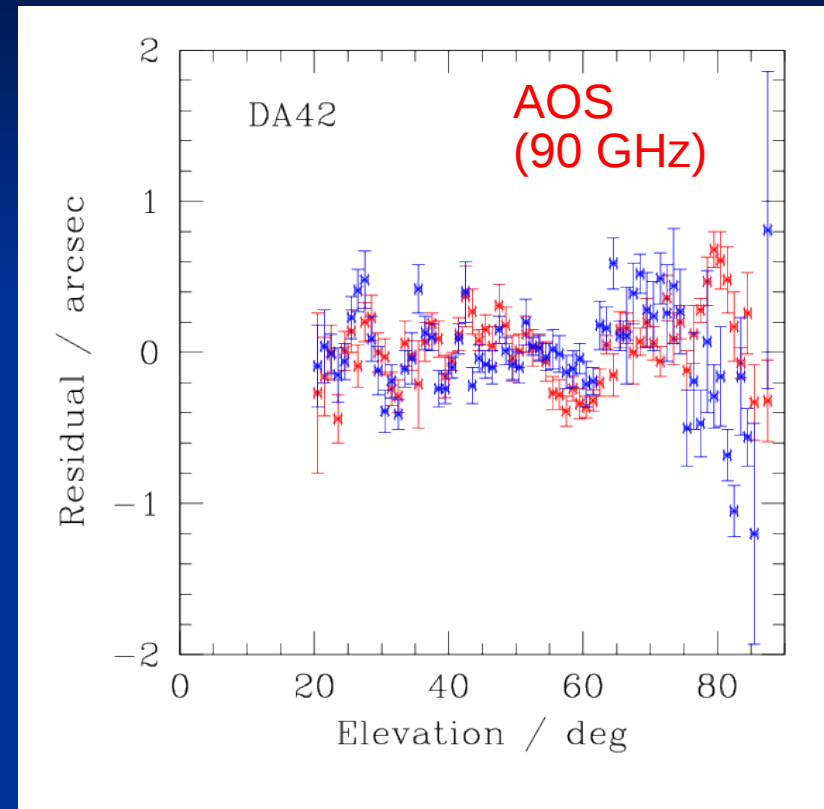
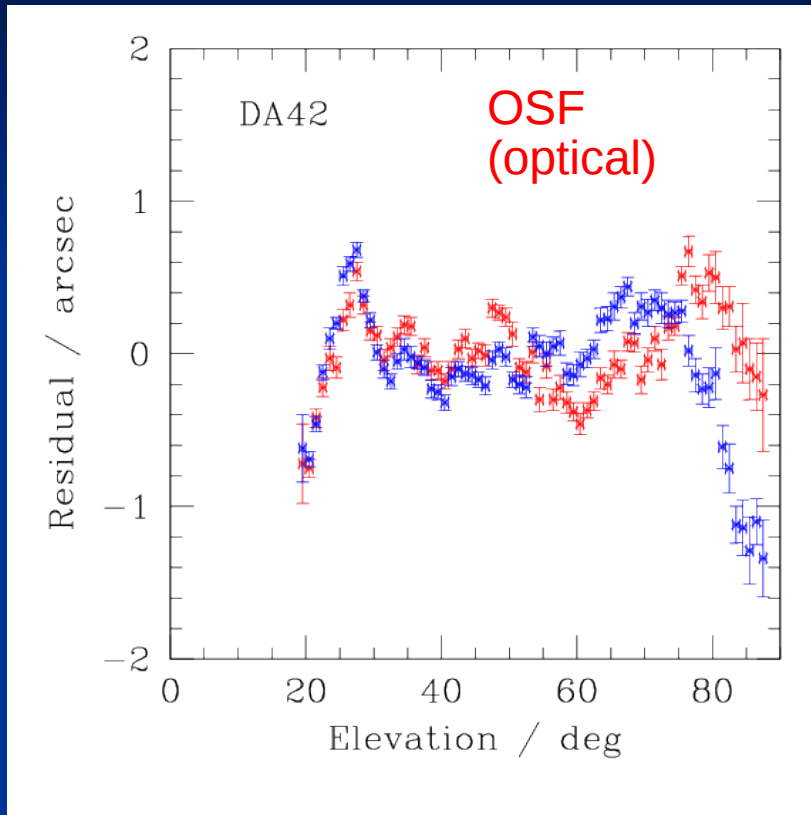

Small, systematic residuals, almost identical in elevation and cross-elevation.
Due to slight deviations from coplanarity in the elevation wheel.
Stable, so correction using look-up tables should be possible.

Interferometric radio pointing

Results of one test
at AOS

RMS 0.8 arcsec

Harmonic terms
fixed

90GHz (Band 3)

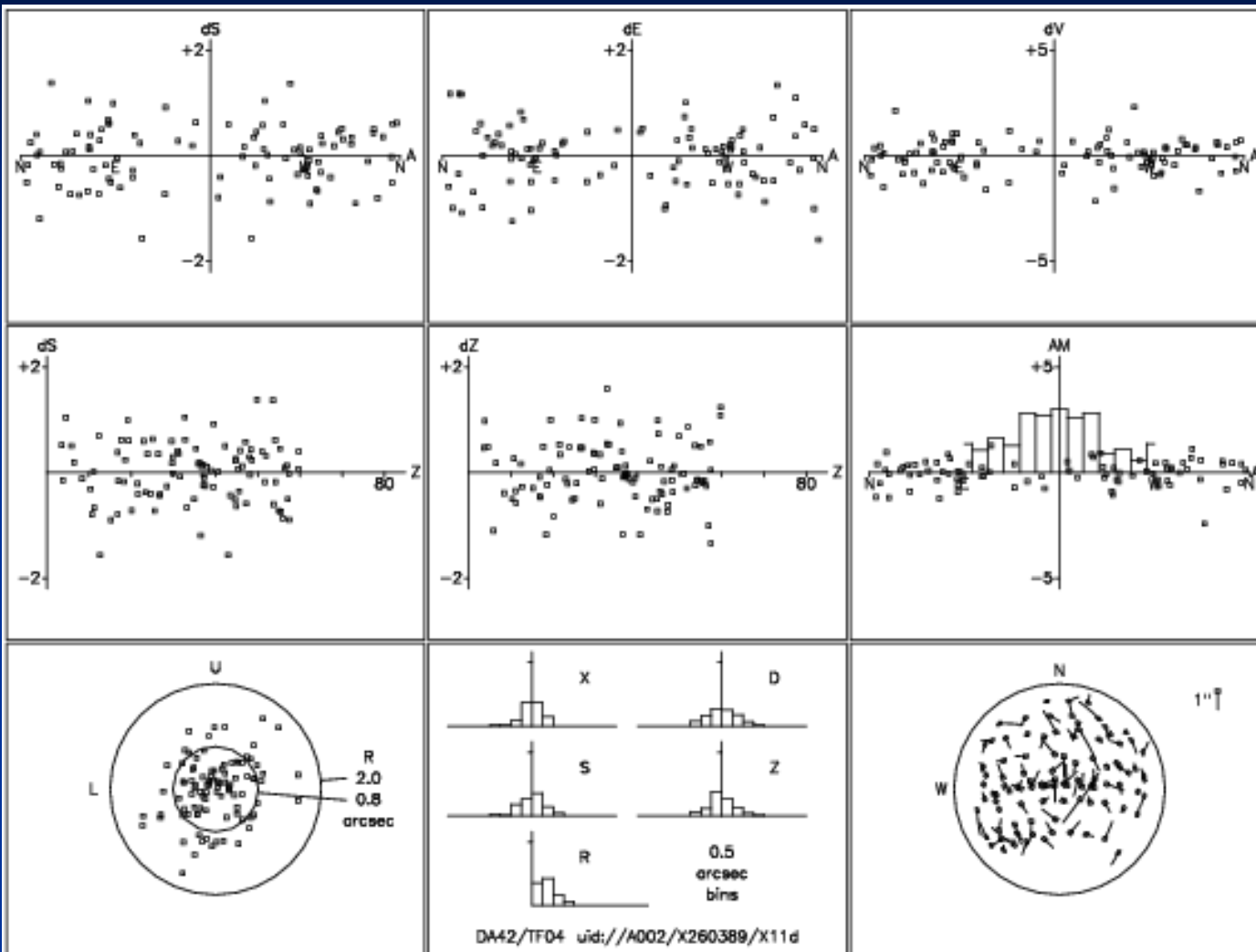



Metrology Systems



- Thermal
 - FEA predicts that antenna will not meet absolute pointing requirement in all temperature conditions
 - Temperature sensors distributed over steel structure
 - Finite-element model
 - Corrects absolute pointing
 - Always enabled
- Dynamic
 - Fast-response tiltmeters
 - Designed to correct for wind-induced transients
 - Used only for offset/reference pointing



Thermal Metrology (1)

- 83 thermal sensors currently used for pointing (+3 in apex)
 - 15 in the base
 - 34 in the yoke base
 - 17 in each yoke arm
- Two-part model, gives vertical displacement and tilt at 3 points on the structure: E (base of yoke), A and B (tops of yoke arms)
 - Base 15x3 matrix $\rightarrow [u_z(E), \alpha_x(E), \alpha_y(E)]$
 - Related to pointing model by $AN = -\alpha_x$ and $AW = -\alpha_y$
 - Yoke 68 x 6 matrix $\rightarrow [u'_y(A), u'_z(A), \alpha'_x(A), u'_y(B), u'_z(B), \alpha'_x(B)]$
 - Primed coordinate system rotates with the antenna



Thermal metrology (2)

- Yoke terms also related to pointing model
 - Elevation error $-IE = \alpha'_x(A)$
 - Azimuth rotation error $IA = [u'_y(A) - u'_y(B)]/D$
 - Axis non-perpendicularity $NP AE = [u'_z(A) - u'_z(B)]/D$
- Matrices stored in the ACU; assumed to be the same for all antennas

Example thermal load case

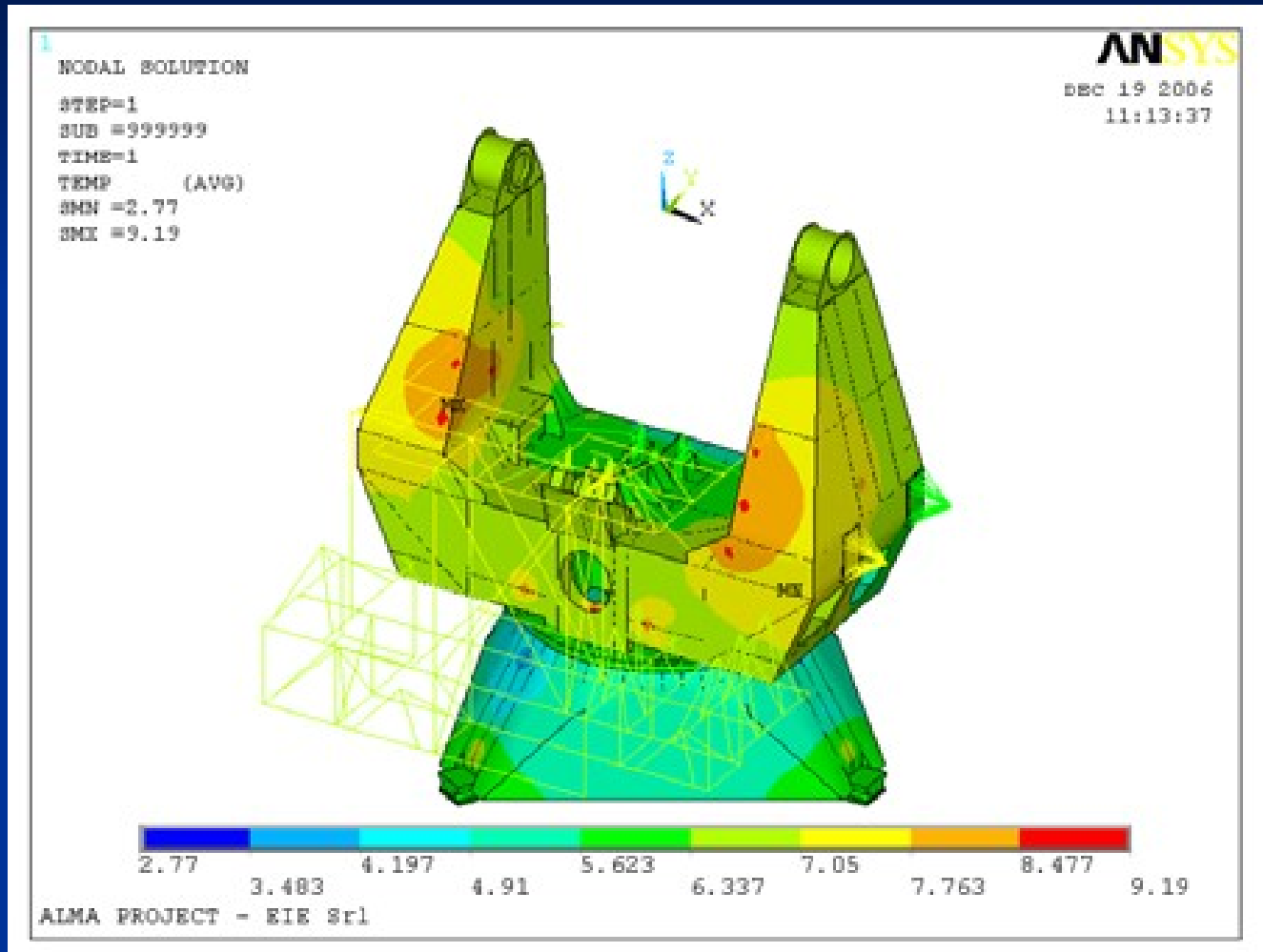

Thermal sensor variations

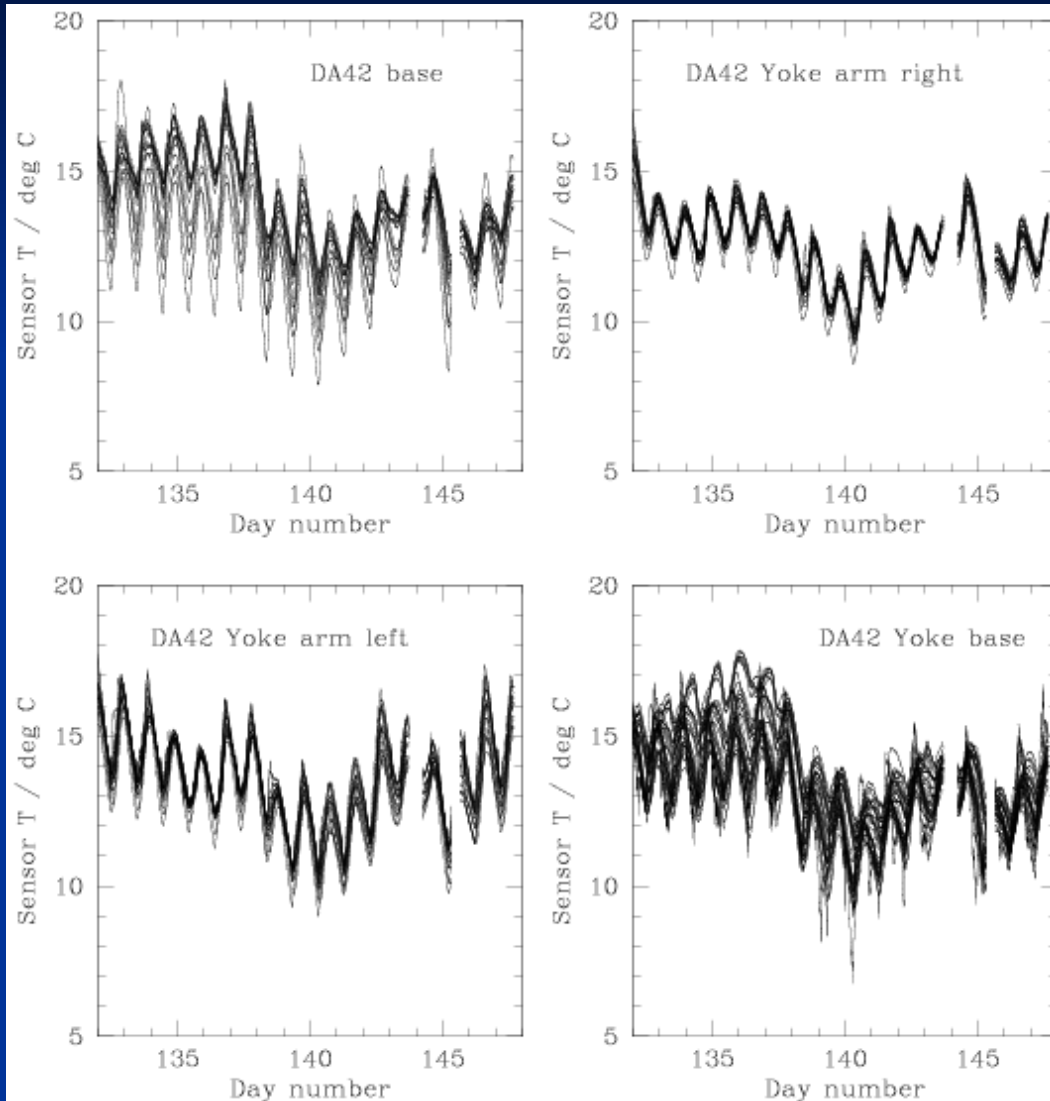

Structure is well insulated

Structural temperature variations are damped cf. ambient, and follow with a lag of several hours

Sensors appear to be well-calibrated and reliable

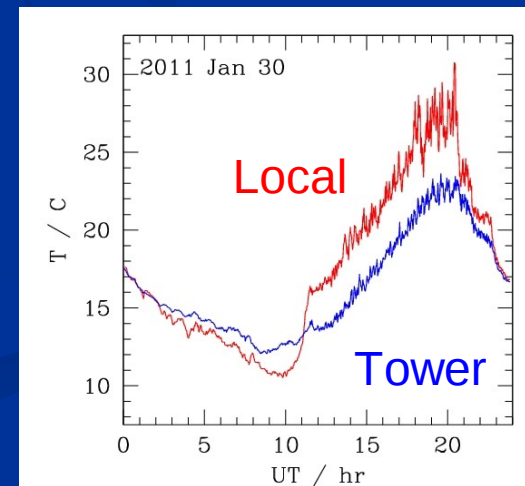

Predicted pointing model coefficients

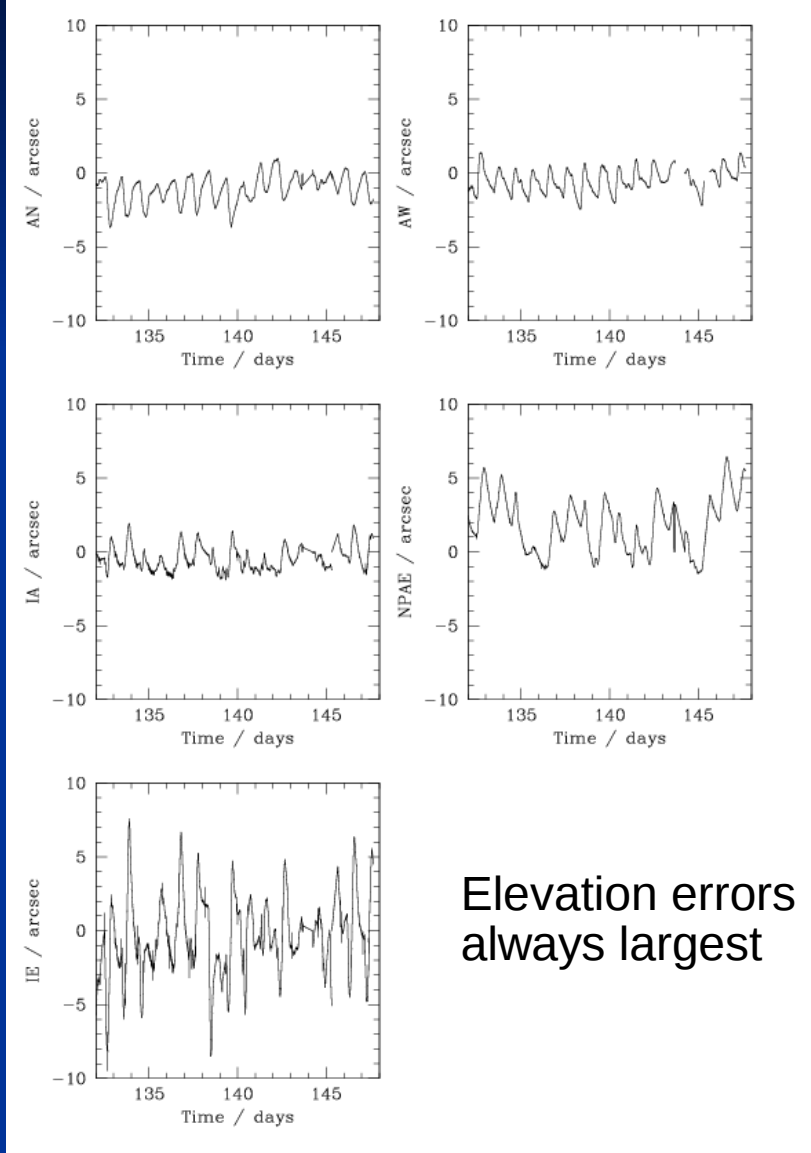



Testing the yoke model

- All-sky pointing tests are done with thermal metrology enabled
 - Temperature sensors are logged throughout
 - Calculate correction applied by the yoke metrology matrix and add to the TPOINT data file as an auxiliary term for each measurement
 - Re-analyse pointing data with the correction removed in software
- Makes almost no difference for individual pointing tests
 - thermal effects are slow
 - thermal deformations are fitted as part of the standard pointing model
- Causes significant changes **between** tests a few days apart – typically adds 1 – 2 arcsec in quadrature
- Tested routinely for every antenna

Yoke metrology test

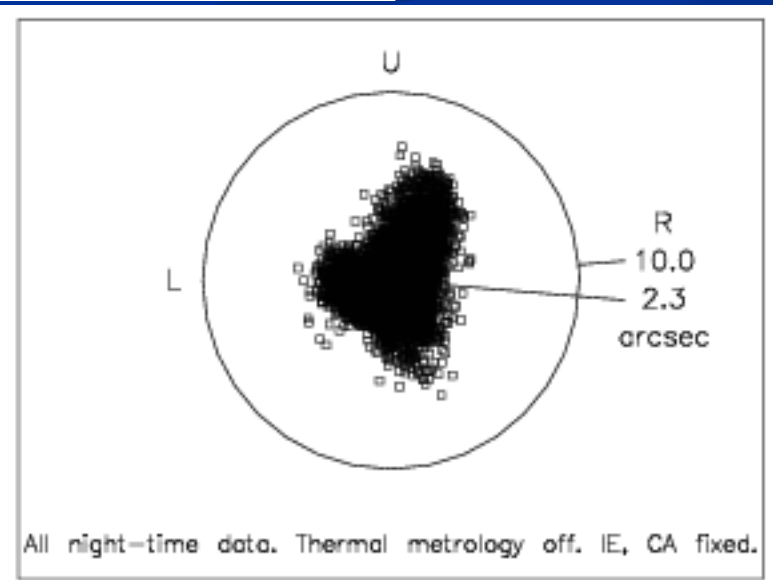
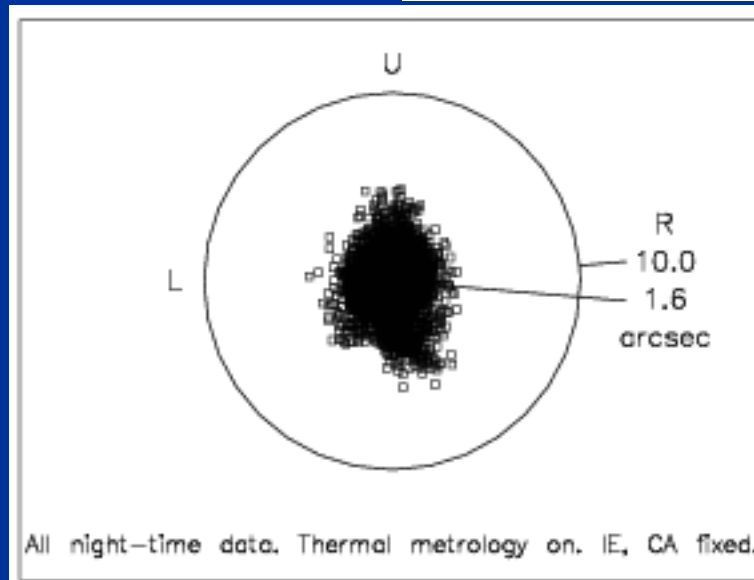
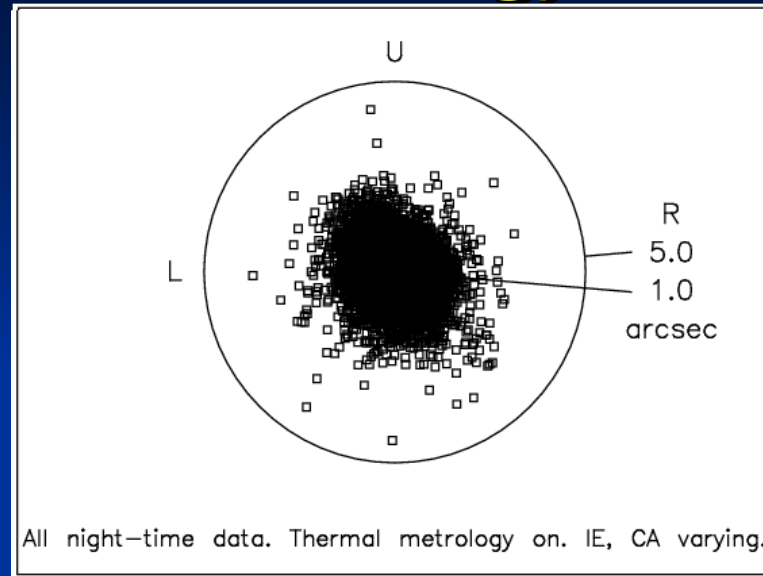



Base Metrology Calibration

- Finite-element model not quite right for the tilt of the base
- Fit (DA42), exploiting the symmetry of the design to reduce the number of free parameters
- Revised matrix used for all antennas
- Should probably be revisited now we are confident that we can remove the effects of foundation tilts (see later).

Base tilt

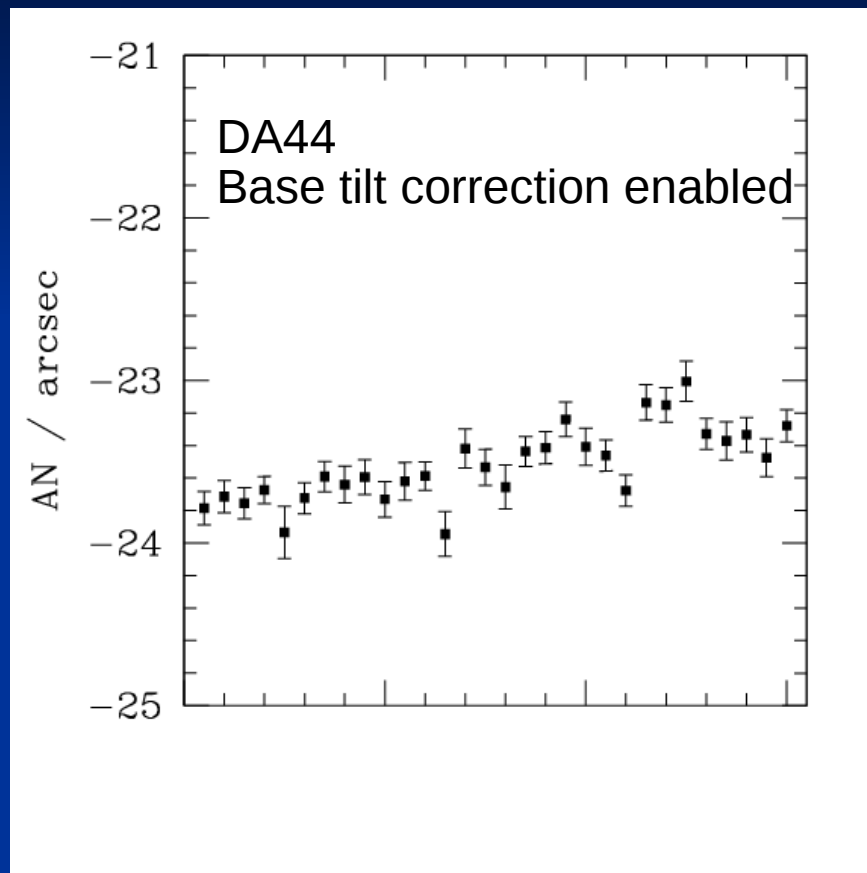
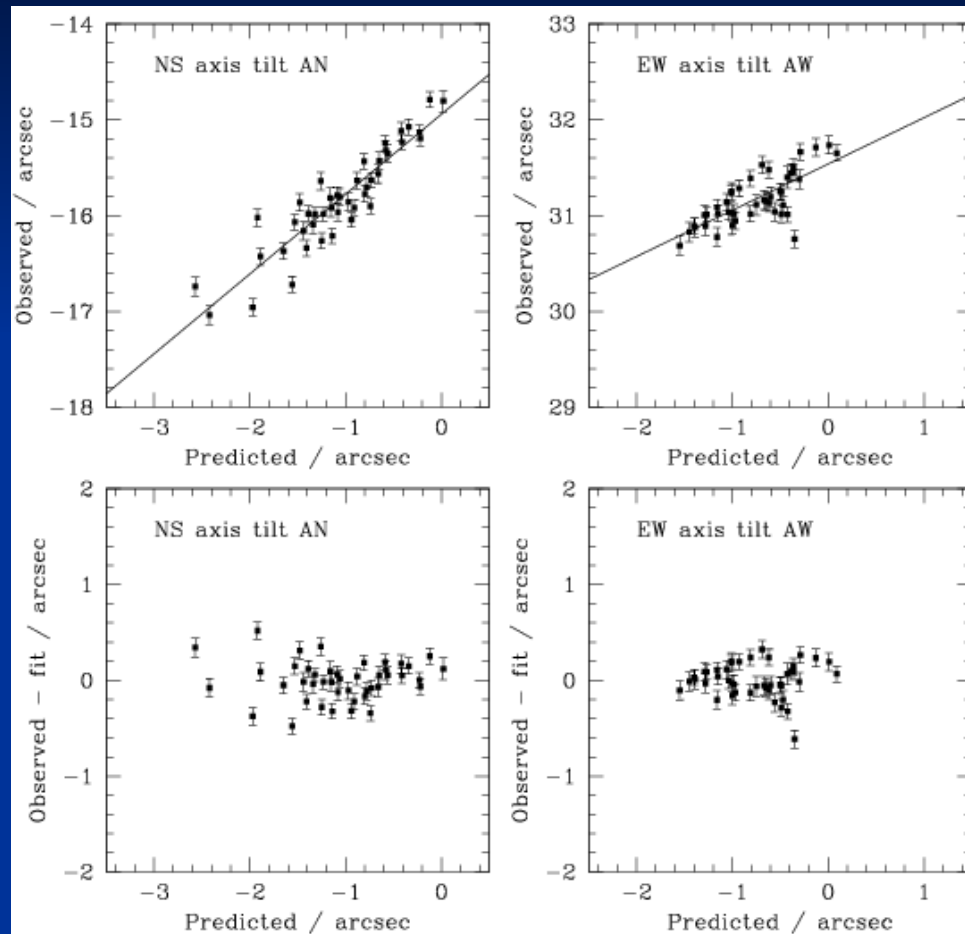

Thermal model of base modified to fit observed tilts



Residual tilts

- Thermal metrology system only corrects for effects in the steel structure
- There are residual tilts due to the foundations
- Can measure and correct these using 360 degree test (see later)



Dynamic Metrology

- Based on two high-accuracy, fast-response tiltmeters on the yoke base
- Actually want to measure at the top of the yoke arms, but tiltmeters placed there are too sensitive to 'in-plane deformations' (i.e. accelerations normal to the instrument axis)
- Left tiltmeter measures elevation error; difference Right-Left measures cross-elevation error. Multiply by 1.5 to get values at top of yoke arm.

Tiltmeter locations

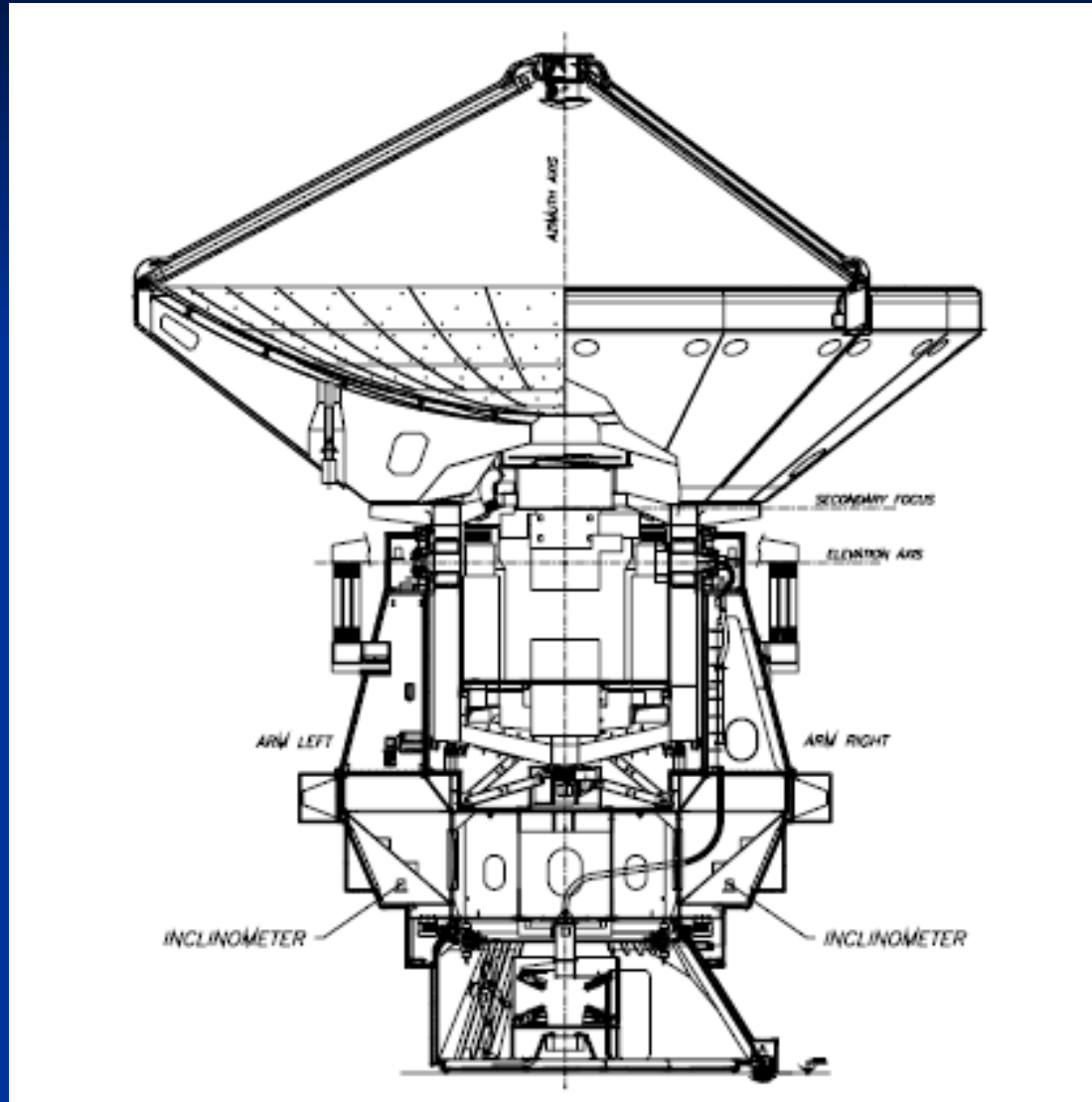

Servo

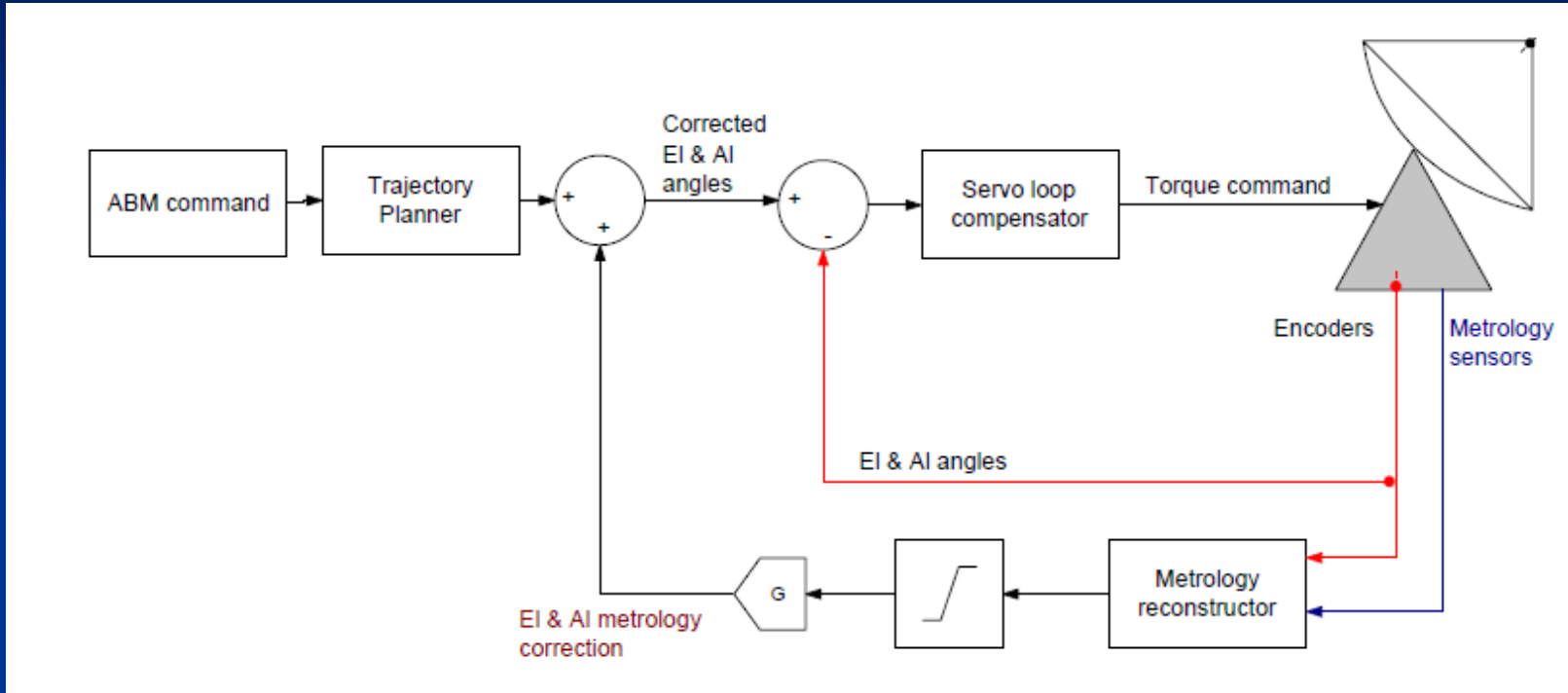



AN0, AW0 and all that

- Azimuth axis not perfectly aligned with the local gravitational vertical (AN0, AW0)
- If not corrected, this gives a sinusoidal error in the tiltmeter reading
- $\Delta E = -AN0 \cos A + AW0 \sin A$
- The misalignment between the Azimuth axis and the geocentric vertical is already measured and corrected in the pointing model (AN, AW). Expect AN-AN0 and AW-AW0 constant on a given pad.
- Therefore measure the values of AN0 and AW0 by rotating the antenna by 360 deg and fitting the resulting values with a sine curve; download to ACU and subtract from tiltmeter readings

Tiltmeter 360 deg rotation

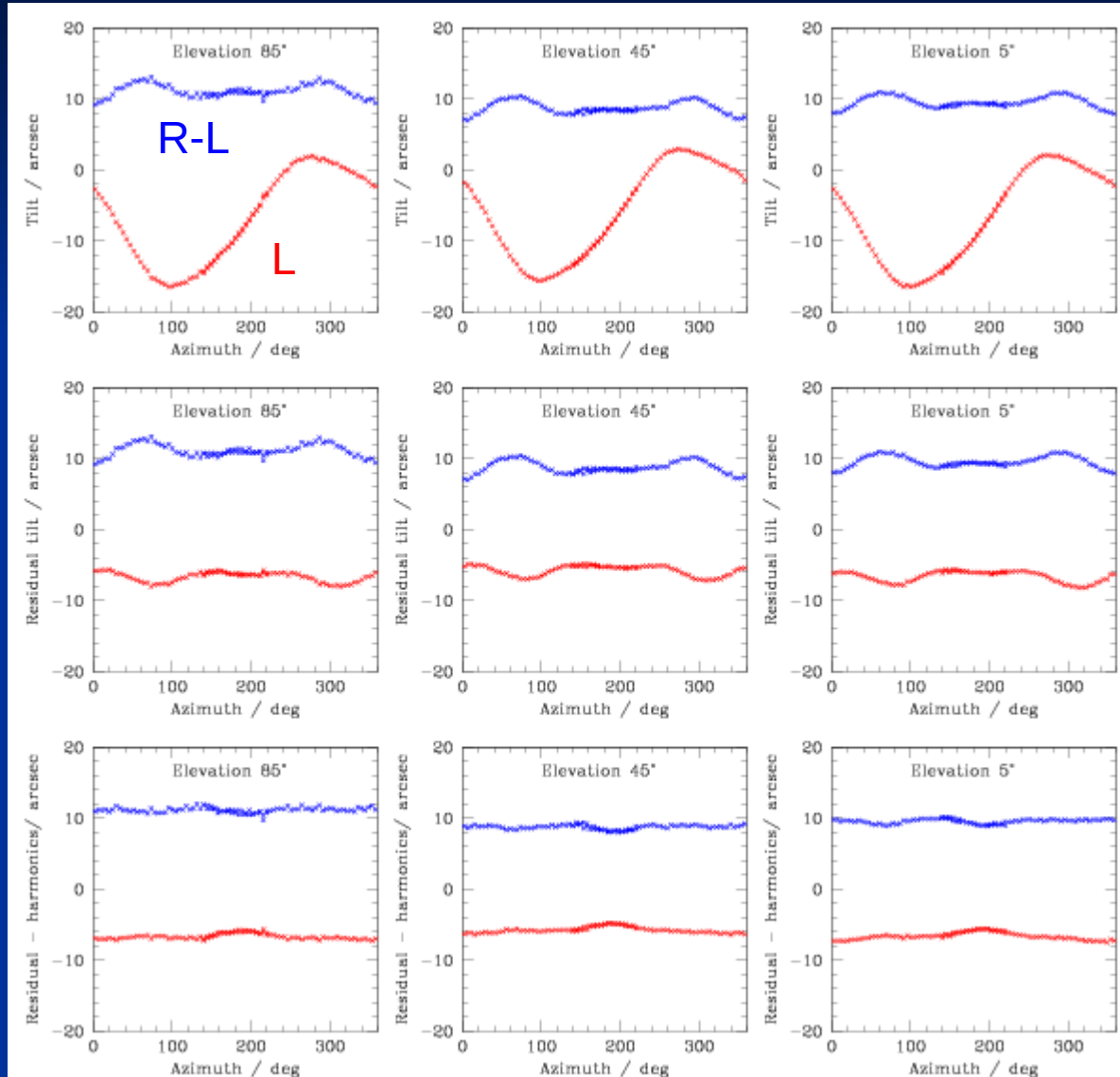

360 deg rotation

Fit and subtract first harmonic

Subtract harmonic terms from pointing model

Sky vs tiltmeter (DA53)

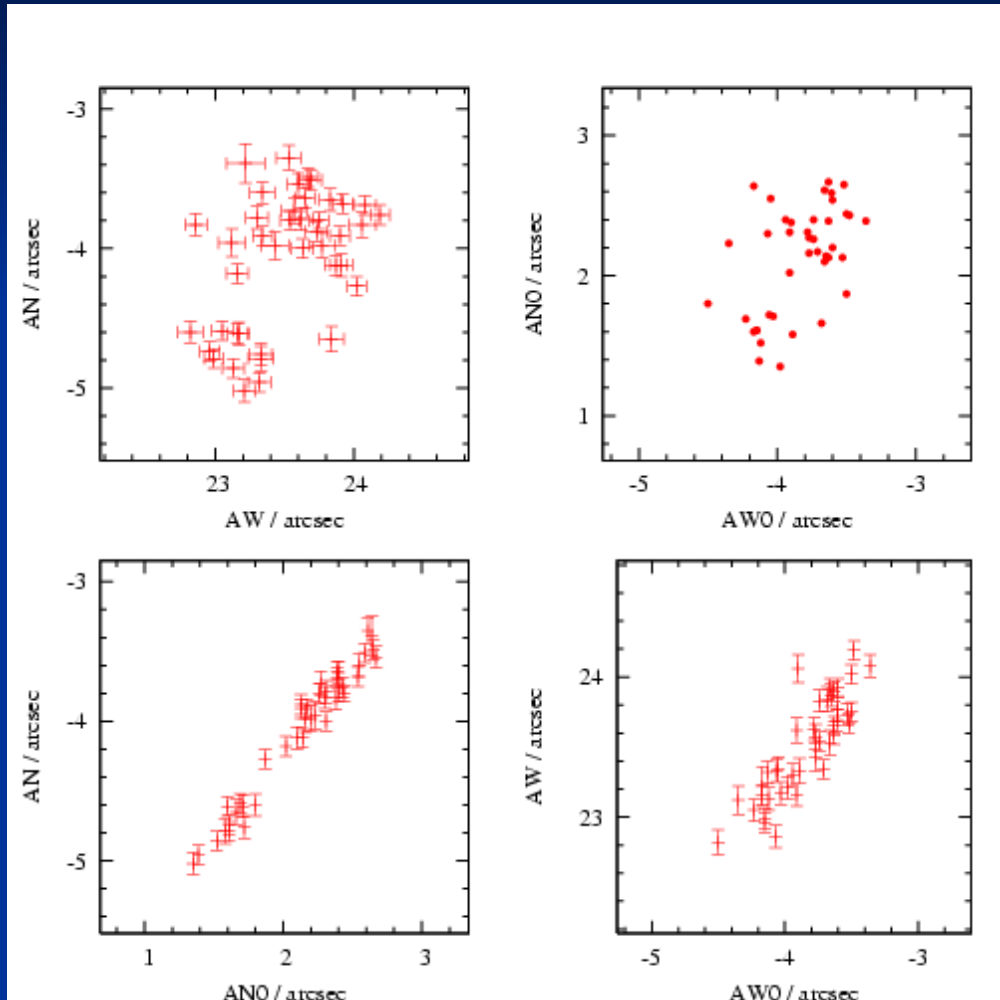

Monitor these values (minus thermal metrology corrections) and use them to correct for foundation tilts.

Also worth considering subtracting the harmonic terms from the pointing model, although these are just over 1 arcsec at most.



Operation of tiltmeter metrology

- Default mode of operation thermal metrology only.
- When on-source on the pointing calibrator, wait 500 ms for tiltmeter to stabilise, then enable both thermal and dynamic metrology and reset the latter (just a software zero-point correction).
- Keep this mode until slewing to the next pointing calibrator, then revert to thermal metrology only.
- Very difficult to test!

Does it work?

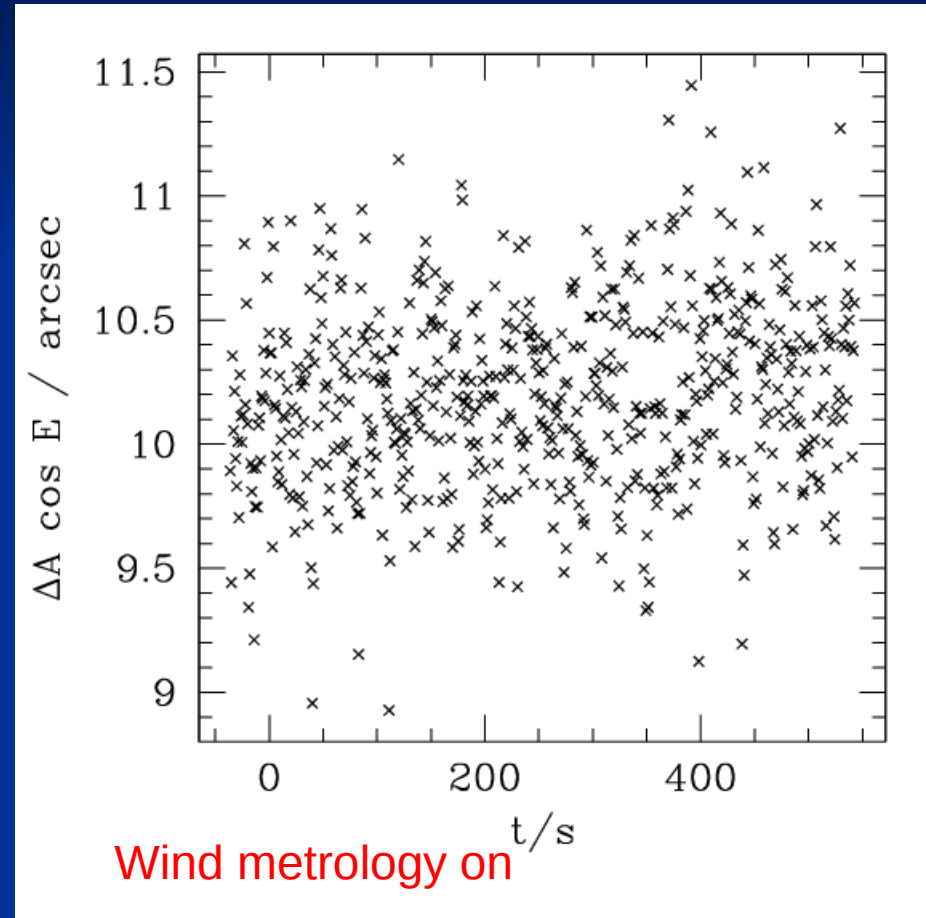
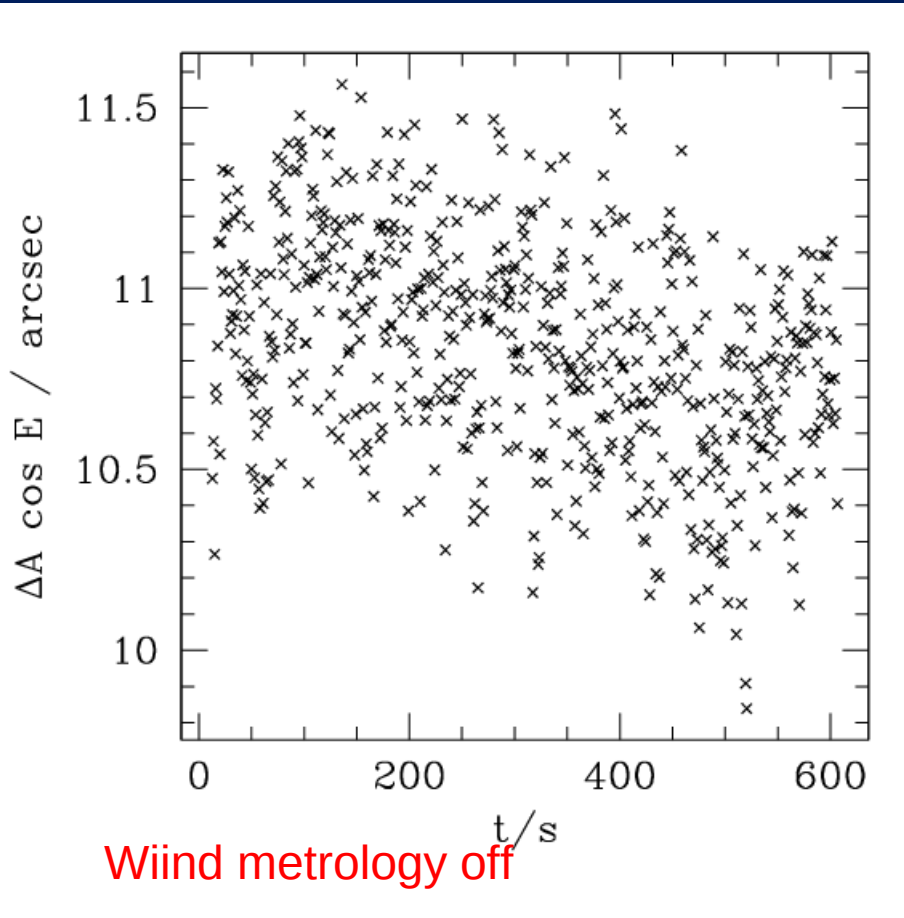

Very difficult to tell with the OPT: no visible difference in calm conditions (none expected); very hard to measure in windy conditions.

Offset Pointing

Specification 0.6 arcsec for 1.5 deg offset

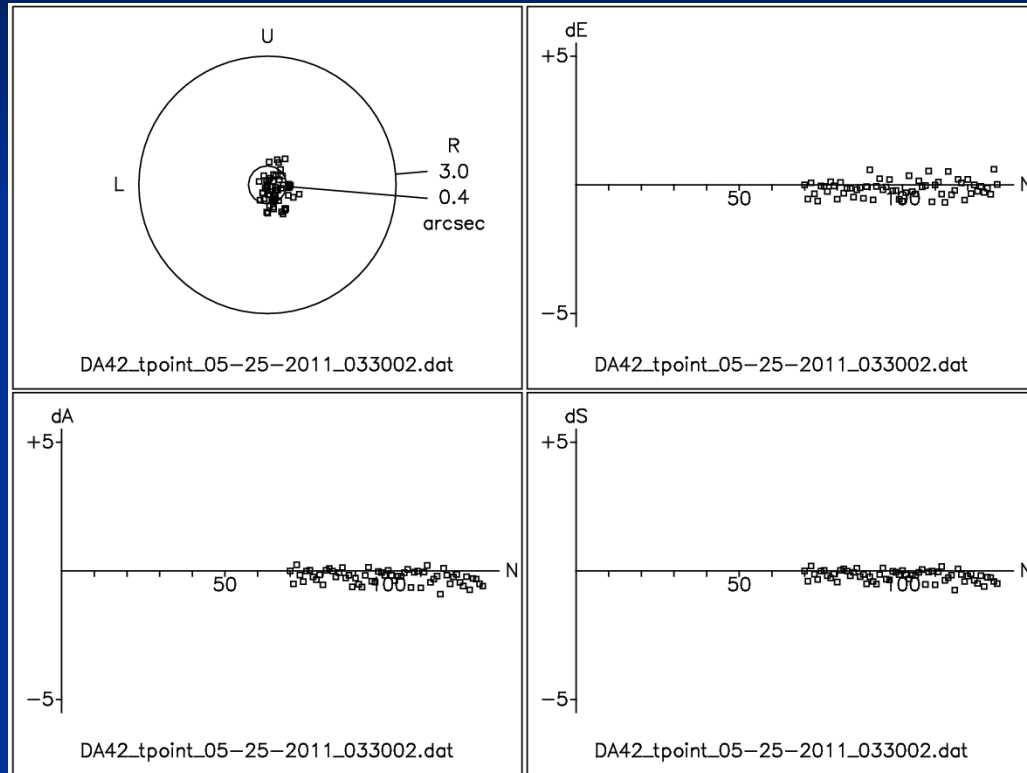

Analysis

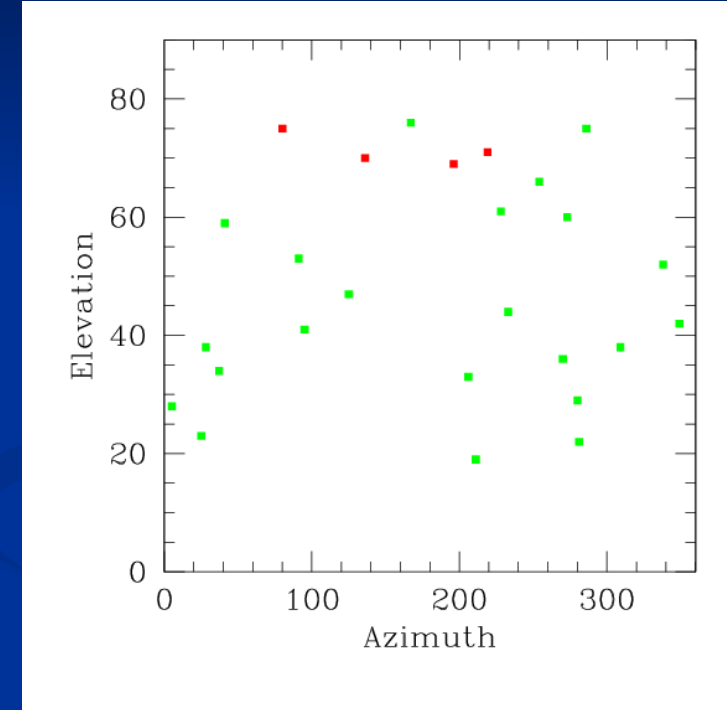

Sky coverage



Offset Pointing Summary

- 0.6 arcsec specification met with thermal and tiltmeter metrology active (or not)
- Best and worst rms 0.36 arcsec (DA42)/0.55 arcsec (DA43)
 - Dependent on OPT stability (OPT2 gives consistently better results than OPT1)
 - Very delicate measurement

Step response

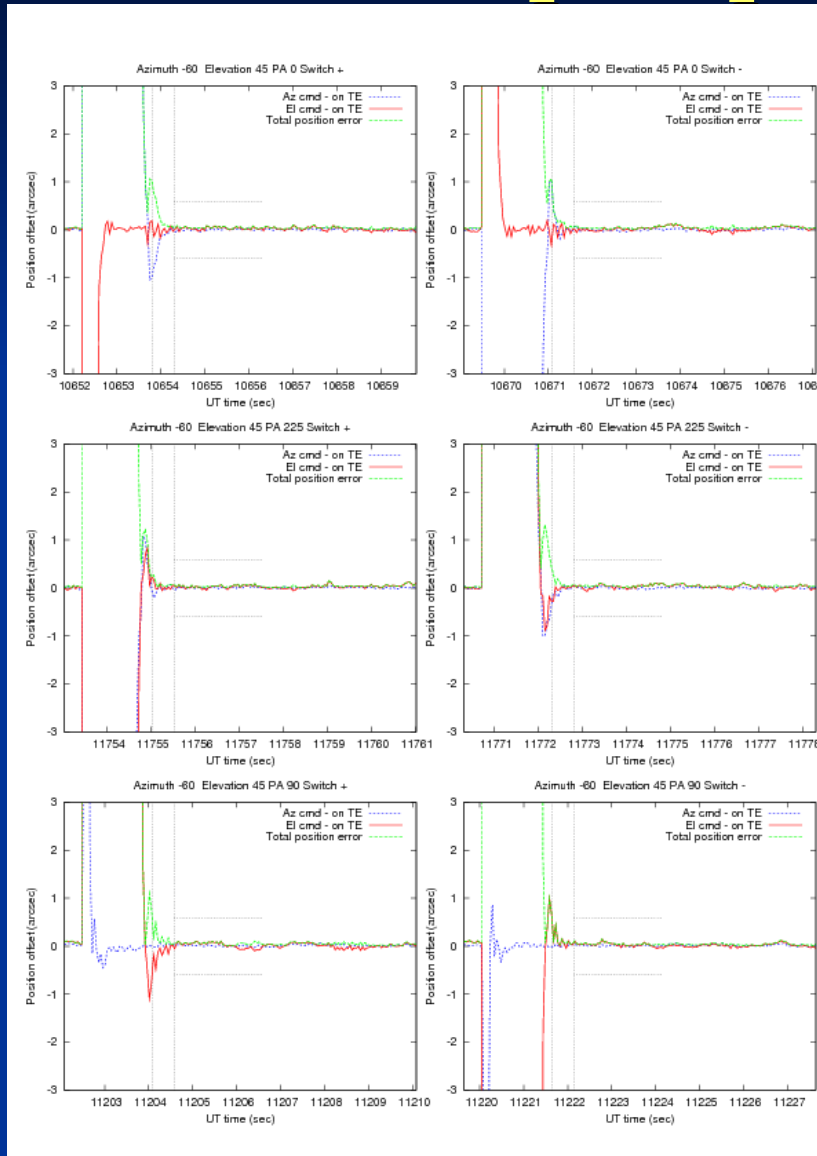

No fails below 10 ms^{-1}
wind speed

Full metrology active
(or not)



Step response numbers

- Specification: for a 1.5 deg move on the sky, settle to within 3 arcsec peak after 1.5s and <0.6 arcsec rms in $t = 2 - 4$ s.
- 21 positions in a grid over the sky
- All passed for all 25 antennas
- Typical numbers
 - Mean 0.34, worst case 0.99 arcsec after 3s.
 - Maximum rms 0.11 arcsec after 2 - 4 s; mean 0.037 arcsec.



Lessons

- Thermal metrology works extremely well for simple steel structures
 - More care is needed for constrained structures
- Tiltmeters can provide a very accurate measure of Azimuth axis direction
- Optical pointing telescopes can work very well
 - .. but ensuring long-term and thermal stability and reliability is very hard
- Need to think a lot harder about test procedures for metrology systems
 - How can we evaluate the wind metrology system?
 - Verifying offset performance was only just within the capabilities of the test setup



Summary

- Thermal metrology functions well
 - Also good prediction of variations in residual delay
- Foundation tilts need to be monitored with the tiltmeters and, if necessary, compensated
- Correction for residual elevation-dependent errors is possible
- Offset pointing performance is within specification
- Step response is well within specification
- Dynamic metrology needs to be better tested in windy conditions at AOS. It is working as best we can tell from OPT tests at OSF.