



---

# IDERA ER/Studio® Business Architect

## User Guide

Version 16.5/2016+  
Published February 2017

---

© 2017 IDERA, Inc. All rights reserved. IDERA and the IDERA logo are trademarks or registered trademarks of IDERA, Inc. Database tools product names are trademarks or registered trademarks of Embarcadero Technologies, Inc., a wholly owned subsidiary of IDERA, Inc.

March 2, 2017

# Contents

Welcome to ER/Studio Business Architect .....	8
About ER/Studio Business Architect .....	11
About the User Guide .....	13
Technical requirements .....	13
Hardware requirements .....	14
Operating system requirements.....	14
Product resources.....	14
Licensing ER/Studio Business Architect .....	15
Uninstalling ER/Studio Business Architect .....	15
Additional product resources .....	15
IDERA technical support .....	16
Contacting IDERA Technical Support .....	16
Application basics .....	19
Product design .....	19
Navigation.....	21
Model view .....	21
Palettes .....	21
Toolbars .....	34
Menus .....	50
Shortcut menus.....	57
Keyboard commands .....	110
Preferences.....	114
Preferences Editor .....	114
Business process modeling .....	116
Conceptual modeling.....	117
Default values .....	117
Diagrams .....	121
Find/Search .....	122
Formatting .....	122
Import/Export .....	136
License Manager .....	141
Messages .....	141

## CONTENTS

Model view .....	142
Naming.....	142
Property views .....	145
Reporting.....	145
Repository options.....	145
Workspaces/Models .....	145
Using ER/Studio Business Architect.....	145
Workspaces and projects.....	145
Using workspaces .....	146
Using projects .....	154
Using models.....	161
Working with models.....	162
Processes – Business Process modeling .....	166
Diagrams and elements .....	171
Using diagrams.....	171
Using diagram elements .....	181
Reference objects .....	194
Using business elements.....	196
Using business rules.....	197
Using business units.....	197
Using domains.....	200
Using stewards.....	201
External data objects .....	202
Creating external data objects.....	204
Deleting external data objects.....	209
Drawing shapes.....	209
Characteristics:.....	209
Working with ER/Studio Repository .....	210
Specifying Repository connection details.....	210
Setting Repository options .....	210
Logging in and out of the Repository.....	211
Establishing security for the Repository .....	211
Creating and managing roles .....	213
Creating and managing users .....	214

Granting and prohibiting user access to Repository items.....	215
Working with objects in the Repository .....	216
Adding a workspace to the Repository .....	217
Retrieving a Repository workspace .....	217
Getting the latest version of a workspace .....	217
Saving changed items to the Repository (Checking in).....	218
Checking out Repository items .....	218
Discarding changes made to a checked out workspace .....	219
Deleting workspaces from the Repository .....	219
Using business process modeling notations.....	220
Business process modeling elements .....	222
Events.....	222
Activities.....	237
Gateways .....	242
Connection elements.....	251
Swimlanes .....	254
Artifacts.....	265
Using conceptual modeling notations .....	267
Conceptual model elements.....	268
Subject area .....	270
Business entities .....	273
Business attributes.....	275
Interaction .....	291
Relationship .....	292
ER/Studio Business Architect tools.....	295
Create diagram from selected elements .....	295
Creating b usiness p rocess m odel d iagrams .....	296
Creating c onceptual m odel d iagrams .....	296
Find .....	297
Finding in diagram.....	297
Finding in Model view.....	298
Search .....	298
Search Results v iew .....	299
Links .....	301

## CONTENTS

Creating a link.....	302
Usages.....	307
Creating a usage.....	307
Editing u sage.....	309
Exporting a usage.....	310
Drawing a usage.....	311
Impact analysis diagram.....	312
Updating an Impact Analysis d iagram.....	313
View an Impact Analysis d iagram in the Grid Editor.....	314
Grid Editor.....	314
Opening the Grid Editor.....	316
Using the Grid Editor.....	317
Using the Grid Editor for entering reference objects data.....	318
Exporting the Grid Editor.....	320
Importing data exported from the Grid Editor.....	320
Customizing the Grid Editor.....	321
Reports.....	322
Impact Analysis report.....	322
Web report.....	324
Views.....	327
Diagram view.....	330
Model view.....	332
Palette view.....	338
Error Logging view.....	340
Help view.....	344
Overview window.....	346
Search results.....	347
ER/Studio Business Architect tools – Importing and exporting.....	349
CSV file import.....	350
Conceptual models.....	353
Conceptual model import from ER/Studio Data Architect.....	353
Conceptual model update from ER/Studio Data Architect.....	356
Conceptual model export to ER/Studio Data Architect.....	358
External data objects.....	362

External data object import from ER/Studio Data Architect ..... 362

External data object update from ER/Studio Data Architect files ..... 363

External data object export to ER/Studio Data Architect ..... 365

Visio import..... 366

    Mapping Visio objects to ER/Studio Business Architect objects ..... 370

Property views ..... 375

    Workspaces..... 375

    Projects ..... 376

    Models ..... 379

    Diagrams ..... 382

    Business process modeling diagram elements ..... 388

        Events..... 389

        Activities..... 407

        Gateways..... 435

        Connecting objects ..... 445

        Swimlanes ..... 465

        Artifacts..... 478

    Conceptual modeling diagram elements..... 489

    General diagram elements ..... 508

        Reference objects ..... 509

        External data objects ..... 530

        Drawing shapes..... 562

Glossary..... 575

# Welcome to ER/Studio Business Architect

ER/Studio Business Architect (previously known as EA/Studio) applies two different types of modeling: Business Process Modeling Notation (BPMN), and Conceptual Modeling. These modeling processes allow you to integrate roles from various constituencies to collaborate, agree, create, and enable executable processes.

The Business Process Modeling portion of ER/Studio Business Architect (ER/Studio BA) is a visual modeling application that focuses on business process modeling and its relationship to related enterprise and data artifacts. Business processes do not exist in a vacuum within the organization, so ER/Studio BA allows you to link key business process information to data, organization, rules, etc. to get a broad view of the organization and show how processes and data impact one another.

The Conceptual Modeling portion allows Data Modelers to create high-level designs of core business concepts to gain acceptance and requirements from the business. These high-level Conceptual models can be forward engineered to create detailed Logical Data Models in ER/Studio. You can relate data objects to business process information and create Usage (CRUD) and Impact Analysis reports. In addition to process-specific information, related business information can also be linked to data objects such as business rules, business elements, business units, and stewards.

Through robust reporting, modeling, and graphical impact analysis, users are able to provide relevant information to various stakeholders within the organization in a format that makes sense to them. For example, a data analyst may wish to see a Usage (CRUD) report showing what data is used by a given process for compliance. A business user may want to see a list of relevant business rules in a spreadsheet. A process modeler needs to see a semantically-rich process model. ER/Studio BA allows each stakeholder to see a different “slice” of information—all from the same data source and metadata model.

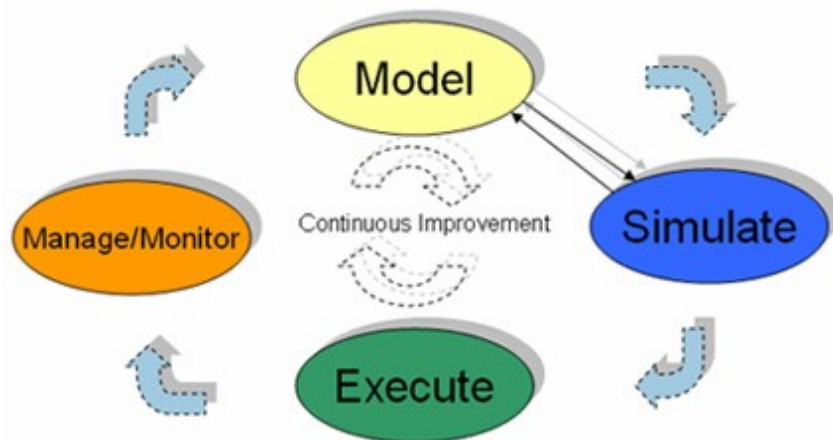



# About ER/Studio Business Architect

ER/Studio BA is used for creating graphical representations of your business from the core concepts that describe the business, to the processes detailing how your business operates. You can model business processes and how those processes use data. The Business Process Modeling is based on the BPMN standard.

The Conceptual Modeling provides intuitive ways to outline subject areas and concepts that can then drive the creation of detailed data models. The Conceptual Modeling uses high-level representations allowing for top-down database design.

Functionality	Description
<a href="#">Conceptual Modeling</a>	
Conceptual Model Creation	Support for high-level conceptual modeling using elements such as subject areas, business entities, interactions, and relationships.
Relationship Traceability	Model links between any conceptual or process modeling elements allowing you to trace relationships between models.
<a href="#">Conceptual Model Export</a>	Conceptual models can be exported to ER/Studio to become the foundation for creating ER/Studio logical data models. The export uses pre-defined mapping.
<a href="#">Business Process Modeling</a>	
Process Model Creation	Support for straightforward process modeling that uses standard elements such as sequences, tasks, swimlanes, start events, and gateways.
BPMN Compliance	Optional automatic validation of process diagrams to ensure compliance with the BPMN specification and prevent the addition of non-compliant modeling elements.
Embedded sub-process support for functional decomposition	Independent sub-processes and embedded collapsible sub-processes can be included within a business process to allow for maximum flexibility in diagramming, while still ensuring a workable visual diagram.
<a href="#">Impact Analysis Reporting</a>	
Multi-object, Multi-level Reporting	Impact analysis reports can be generated to show interrelationships between process, data, stewardship, business rules, diagram usage, heritage, connecting objects etc.
Report Filtering	Impact analysis reports can filter based on type of relationship, object type, or text strings including wildcard matching.
Usage (CRUD) Reporting	
Link Process with Data	The relationships between business processes and data objects can be modeled to identify what processes create, read, update, or delete data objects.
CRUD Reporting	CRUD reports identify which processes affect which data, and what affects they have. Reports are available in a straightforward spreadsheet view.
Report Filtering	Reports can be shown across object types, or can be filtered based on individual object types such as tasks or business processes, allowing users to drill down based on specific requirements.
Business Artifact Modeling	
<a href="#">External Data Objects</a>	Support for data objects which are general data storage constructs that can represent databases, file systems, or other data storage mechanisms.

Functionality	Description
<a href="#">Business Elements</a>	Captures business terms that can later be used to enforce naming standards or as the foundation of logical data models.
<a href="#">Business Rules</a>	Incorporate policies, practices, or formulas related to business processes as part of the process model elements and metadata processes, allowing users to drill down based on specific requirements.
<a href="#">Business Units</a>	Create and incorporate business units into process models such as sales, human resources, or accounting.
<a href="#">Stewardship</a>	Support for inclusion of organizational roles such as 'DBA' or 'Sales Manager' to incorporate ownership for specific processes or tasks.
<a href="#">Links</a>	Create generic associations between objects for impact analysis and CRUD reporting.
User Interface	
Organizational Hierarchies	ER/Studio BA allows you to organize your information to align with your business strategy, allowing for a Project-based tree hierarchy which can group multiple model types and diagrams into intuitive projects to allow for alignment with business initiatives or organizations.
Flexible Interface	Full support for multiple property editors, tab-based navigation, undo/redo, collapsible nested tree views, zoom-based navigation, and keyboard shortcuts.
Flexible object formatting and display options	Ability to customize a wide variety diagram options including line width, color and fill options, font displays, line connector points, line bend formats, etc.
<a href="#">Grid Editing</a>	A table-based alternative to the hierarchical tree view, allowing the display of large numbers of objects or business rules in an easy to read format.
<a href="#">Publish Model to Web</a>	Automatically generate HTML views of your models to share with other people in your organization.
Import / Export	
Share Information Across Multiple Roles and Formats	Can share process models among a broad range of user groups by exporting them into a wide variety of supported formats including xml, csv, html, pdf, rtf, and jpeg.
<a href="#">ER/Studio Import/Export</a>	Import and export ER/Studio Business Architect models for use as data assets or Conceptual diagrams.
<a href="#">Visio Import</a>	Configurable import capabilities let you import diagrams from Microsoft® Visio®.
Collaboration and Reporting	Connect to ER/Studio Repository to share workspaces, diagrams, and models. Connect to ER/Studio Portal to explore and report on ER/Studio BA objects in ER/Studio Repository. For more information, see <a href="#">Working with ER/Studio Repository</a> .
Architecture	
Separation of Data and Display	ER/Studio BA is based on a metadata foundation that allows core data to be manipulated and displayed in a variety of formats, without requiring a "picture" or diagram, speeding performance and increasing knowledge transfer across multiple constituencies.
Object Reuse	Core processes and enterprise objects can be reused across multiple diagrams, allowing for a "single version of the truth" across the organization.
Standards-Based	ER/Studio BA is based on industry standards: Eclipse-based, XML file formats with published Schema, and BPMN modeling notations.

## About the User Guide

The User Guide focuses on the key features and capabilities of the application. The table below describes the sections of the online Help:

Section	Description
<a href="#">Application Basics</a>	Explains the application design, navigation tools, and important concepts, as well as how to configure the application.
<a href="#">Using ER/Studio Business Architect</a>	Explains how to use workspaces, projects, models, diagrams, and diagram elements as part of the modeling process.
<a href="#">Working with ER/Studio Repository</a>	Explains how to configure and connect to the repository to get, check in, and check out workspaces, diagrams, and models.
<a href="#">Using Business Process Modeling Notations</a>	Explains how to work with the Business Process Modeling Notation.
<a href="#">Using Conceptual Modeling Notations</a>	Explains how to work with the Conceptual Modeling Notation.
<a href="#">ER/Studio Business Architect Tools</a>	This chapter covers the main tools used in ER/Studio BA: Create Diagrams from Selected Elements, Find, Search, Links, Usages, Grid Editor, Reports, and Views.
<a href="#">ER/Studio Business Architect Tools - Importing and Exporting</a>	This chapter covers Conceptual Models Import and Export to ER/Studio, External Data Objects Import and Export to ER/Studio, and Visio Import.
<a href="#">Property Views</a>	Explains the fields in the Property View.
<a href="#">Glossary</a>	Defines words used in ER/Studio BA and this documentation.

For more information, see

- [Technical requirements](#)
- [Product resources](#)
- [Licensing ER/Studio Business Architect](#)
- [Uninstalling ER/Studio Business Architect](#)
- [Additional product resources](#)
- [IDERA Technical Support](#)

## Technical requirements

Before using ER/Studio BA, verify that your environment meets the application hardware and operating system requirements.

## Hardware requirements

ER/Studio BA hardware requirements vary. The table below outlines the minimum recommended requirements for ER/Studio BA:

Hardware	Minimum Requirement
CPU	1.2 Ghz
RAM	1 GB MB of RAM
Disk Space	Hard Drive Install 250 MB Storage - Sufficient space for workspaces, which will vary according to complexity.
Video	SVGA High resolution monitor (1024 x 768 or higher) with high color (16-bit)
Media	CD-ROM or the Internet ( <a href="http://www.idera.com">www.idera.com</a> ).

## Operating system requirements

ER/Studio BA supports the following operating systems:

- Microsoft Windows® XP SP2
- Microsoft® Vista® 2007
- Microsoft Windows® 7, 8.1, and 10

**NOTE:** ER/Studio BA is supported on Windows Vista when using the Windows Vista Basic experience. The premium experience, Windows Aero®, is not supported for use with ER/Studio BA.

## Product resources

The section gives you additional resources that are available to help you use ER/Studio BA. The Object Management Group/Business Process Management Initiative is responsible for generating a standard Business Process Modeling Notation (BPMN) providing business with standard graphical notations for internal business procedures. For more information, see <http://www.bpmn.org>

The Business Process Modeling Notation (BPMN) specification provides standardized graphical notations for expressing business processes in a Business Process Diagram (BPD).

For more information, see <http://www.omg.org/spec/>

## Licensing ER/Studio Business Architect

For information on licensing ER/Studio BA, go to the ER/Studio Enterprise Team Edition *Quick Start Guide* at [www.idera.com/support/productdocuments](http://www.idera.com/support/productdocuments)

## Uninstalling ER/Studio Business Architect

To uninstall ER/Studio BA so you can install a later version, do the following:

1. Click Start > Programs > IDERA ER/Studio Business Architect X.X, and then Uninstall ER/Studio Business Architect. ER/Studio BA opens the Uninstall Wizard.
2. You can select to uninstall all or part of the products. The separate components are: Program Files, Help Documents, and Common Components.
3. Complete the wizard panels, and then click Finish. ER/Studio BA and all its components are uninstalled.

**NOTE:** During uninstallation, you have the option to remove all preference settings. If the settings are removed at this time, all the preferences you have set are lost for future installs.

**NOTE:** The workspaces and their related projects, models and diagrams are stored in a different directory and are not uninstalled.

## Additional product resources

The IDERA Web site is an excellent source for additional product information, including white papers, articles, FAQs, discussion groups, and the Knowledge Base.

Go to [ER/Studio Support](#), or click any of the links below, to find:

- [Documentation](#)
- [Online Demos](#)
- [Technical Papers](#)
- [Discussion Forums](#)
- [Knowledge Base](#)

## IDERA technical support

If you have a valid maintenance contract with IDERA, the Technical Support team is available to assist you with any problems you have with our applications. Our maintenance contract also entitles registered users of IDERA products to download free software upgrades during the active contract period.

To save you time, IDERA maintains a Knowledge Base of commonly-encountered issues and hosts Discussion Forums that allow users to discuss their experiences using our products and any quirks they may have discovered.

To speak directly with IDERA Technical Support, see [Contacting IDERA Technical Support](#) below.

**NOTE:** Evaluators receive free technical support for the term of their evaluation (14 days).

### Contacting IDERA Technical Support

When contacting IDERA Technical Support please provide the following to ensure swift and accurate service:

#### Personal information

- Name
- Company name and address
- Telephone number
- Fax number
- Email address

#### Product and System Information

- IDERA product name and version number. This information is found under Help, About.
- Your client operation system and version number.
- Your database and version number.

#### Problem description

A succinct but complete description of the problem is required. If you are contacting us by telephone, please have the above information, including any error messages, available so that an IDERA Technical Support Engineer can reproduce the error and clearly understand the problem.

## Via the Web

IDERA Technical Support provides an online form that lets you open a Support case via the Web. To access this form, go to [ER/Studio support case](#)

We normally acknowledge the receipt of every case on the same day, depending on the time of submission.

## Via phone

### North America and Latin America

ER/Studio Technical Support phone number is (800) 523-7070. The hours are Monday through Friday, 7:00 A.M. to 5:00 P.M. Pacific time.

### EMEA

ER/Studio Technical Support phone number is +44 (0)1628 684 499. The hours are Monday to Friday, 9 A.M. to 5:30 P.M. U.K. time.

## Via Email

### United States

Depending on your needs, send your email to one of the following:

- [support@embarcadero.com](mailto:support@embarcadero.com) - Get technical support for users and evaluators
- [upgrade@embarcadero.com](mailto:upgrade@embarcadero.com) - Request upgrade information
- [key@embarcadero.com](mailto:key@embarcadero.com) - Request a product key
- [wish@embarcadero.com](mailto:wish@embarcadero.com) - Make a suggestion about one of our products

### EMEA

Depending on your needs, send your email to one of the following:

- [uk.support@embarcadero.com](mailto:uk.support@embarcadero.com)- Get technical support for users and evaluators
- [uk.upgrade@embarcadero.com](mailto:uk.upgrade@embarcadero.com) - Request upgrade information
- [uk.key@embarcadero.com](mailto:uk.key@embarcadero.com) - Request a product key
- [uk.wish@embarcadero.com](mailto:uk.wish@embarcadero.com) - Make a suggestion about one of our products





# Application basics

Application Basics acquaints you with the application and provides information about what ER/Studio BA offers in the way of design, navigation, and general application features. The information presented here is high-level and conceptual. For information on how to use the ER/Studio BA feature set, see [Using ER/Studio Business Architect](#).

ER/Studio BA uses workspaces and projects to organize business process and conceptual modeling. You can use diagrams to create a visual model of both business process and conceptual modeling systems. You can navigate ER/Studio BA by using the application toolbars, menus, shortcut menus, and the keyboard commands.

Application Basics includes three sections:

Topic	Description
<a href="#">Product Design</a>	Explains the views and windows that make up ER/Studio BA.
<a href="#">Navigation</a>	Explains the ER/Studio BA Model View, toolbars, menus, palettes, and keyboard commands used to navigate the application.
<a href="#">Preferences</a>	Explains the different ways you can configure default application settings using Preferences.

## Product design

ER/Studio BA consists of views and windows used to edit, navigate, and display information about each workspace and its corresponding diagrams. The application is broken down into five main categories: [Workspaces](#), [Projects](#), [Models](#), [Diagrams](#), and the [Grid Editor](#).

### Workspaces

A workspace is a unit of storage used for any collection of data modeling projects in ER/Studio BA. You can only open and work with one workspace at a time, but you can add any number of projects and models in a single workspace.

For more information, see [Using Workspaces](#).

### Projects

A project is a unit of storage used for any collection of models and their associated elements in ER/Studio BA. You can have multiple Projects open simultaneously so you can easily switch back and forth between Projects.

For more information, see [Using Projects](#).

## Models

You can create Business Process and Conceptual models. A model is a specific collection of elements/objects related to a specific modeling type, for example the Business Process Modeling Notation (BPMN). A BPMN model would contain those objects associated with a specific business processes: tasks, swim lanes, gateways, etc. Objects within a model are displayed in the Model View tree by type (for example, a grouping node contains all of the tasks within the project).

**NOTE:** If you are modeling with the Business Process Modeling Notation, you can create a model in 'Validation' mode, which enforces the rules of the Business Process Modeling Notation. With Validation set to Off you can use the visual drawing objects without being constrained by the rules of the notation.

For more information, see [Working with Models](#).

## Diagrams

You can create two different types of diagrams:

- Business Process Diagram (BPD): This type of diagram uses a flowcharting technique which is tailored for creating graphical models of business process operations. A Business Process Model is a network of graphical objects, which track the flow of activities and their order of execution.
- Conceptual Diagrams: This is a high level diagram used to explain entities related to the business/organization.

For more information, see [Using Diagrams](#).

## Grid Editor

The Grid Editor enables you to view the objects in the Model View tree in a spread-sheet format. It can be launched from most nodes in the Model View tree. When launched, the Grid Editor appears in the diagram area. If a diagram is already open, it appears as an additional tab.

**NOTE:** If a filter has been set in the tree, this filter carries over to the Grid Editor.

For more information, see [Grid Editor](#).

# Navigation

ER/Studio BA provides tools for navigating the product functionality, and for navigating within and between projects and diagrams. The main navigational areas are:

- Model View
- Palettes
- Toolbars
- Menus
- Shortcut Menus
- Keyboard Commands

## Model view

The Model View appears in the upper left portion of the ER/Studio BA application by default. It contains the Model View tree displaying the hierarchy of workspaces, projects, models, diagrams, and elements. It also displays the hierarchy of reference elements. Workspaces, projects, models, diagrams, and elements can be created, organized, and viewed.

For more information, see [The Model View](#).

## Palettes

The Palette contains the [palettes](#) used to create modeling diagrams in the Diagram View. You can change the display [settings](#) of this palette.



There are seven main palettes: Business Process Objects, Conceptual Objects, Reference Objects, External Data Objects, and Drawing Shapes.





The Modeling palette that is available in the palette depends on what model type you are working with. For example, if you are working in a Business Process Model diagram, the associated palette appears. If you are working with a Conceptual Model diagram, the Business Process Model palette is replaced by the Conceptual Model palette.

For more information, see [Using the Palette](#).

### Palette icons

The table below describes the main elements on the Palette:

Element	Palette Icon	Description
Select		The select cursor allows you to click on elements and select commands.
Marquee		Click this cursor to select multiple items by enclosing them in a frame.

Element	Palette Icon	Description
<a href="#">Business Process Objects</a>		<p>There are six main groups of notation elements:</p> <p><a href="#">Events</a>: There are three types of events: Start, Intermediate, and End.</p> <p><a href="#">Activities</a>: Activities available are: Tasks, Embedded Sub-processes, and Independent Sub-processes.</p> <p><a href="#">Gateways</a>: Gateways control sequence flows. There are five different gateway control types which indicate the flow control behavior.</p> <p><a href="#">Connection Elements</a>: There are three different elements used to connect elements: Sequence Flow, Message Flow, and Association.</p> <p><a href="#">Swimlanes</a>: There are two elements (pools and lanes) that are used to help partition and organize activities.</p> <p><a href="#">Artifacts</a>: There are four different artifacts that allow you to show additional information: Data Objects, Groups, Annotations, and Off-Page Connectors.</p>
<a href="#">Conceptual Objects</a>		This palette contains the five objects used in Conceptual Modeling
<a href="#">Reference Objects</a>		This palette displays the four available reference objects and the link.
<a href="#">External Data Objects</a>		The External Data Objects palette displays the seven different data objects available.
<a href="#">Drawing Shapes</a>		The drawing shapes node contains nine basic shapes you can use to create diagrams. This palette also includes a text label, line, and annotation.

### Palette Settings dialog















The Palette Settings dialog box is where you specify display options for the palette. To open this dialog, right click on any object on the Palette and click Settings. The table below describes the display options:











Option	Description
Layout	<p>Columns: Icons in the palette are displayed in columns.</p> <p>List: Icons in the palette are listed below each main heading.</p> <p>List: Displays both the icon and its descriptive text.</p> <p>Icons Only: Only the icons in the palette are displayed. No labels are shown.</p> <p>Details: Icons in the palette are displayed with labels and descriptions.</p>
Layout Options	The layout option displayed depends on which Layout type you select.
Drawer Options	<p>The contents in the palette are organized using drawers, which open and close. Each group element contains specific Palette Entries. An Entry defines a tool or template for the User. Select one of the options listed below to determine the drawer's behavior.</p> <ul style="list-style-type: none"> <li>• Always close when opening another drawer.</li> <li>• Close automatically when there is not enough room.</li> <li>• Never close.</li> </ul>











## Business Process Objects palette

This palette appears in the Diagram Area when you open or create a Business Process diagram. It is not available if a Conceptual Model is open. If an element has additional options available, a drop-down menu appears to the right of the icon and element name in the palette. For example, if you click the End Event element, six additional end event types are available.









Element	Palette Icon	Description
Start Events		
Start Event		Initiates the start of a Process.
<a href="#">Link</a>		A mechanism for connecting the end of one Process to the start (or trigger) of another.
<a href="#">Message</a>		A message arrives from a participant and triggers the start of the Process.
<a href="#">Rule</a>		This type of event is triggered when the conditions for a rule become true.
<a href="#">Timer</a>		A specific time-date or a specific cycle (e.g., every Friday at 10:00 a.m.) is set that triggers the start of the Process.
Intermediate Events		
Intermediate Event		Happens during the course of a process event.
<a href="#">Cancel</a>		This trigger is used within a Transaction Sub-process. This type of event must be attached to the boundary of a Sub- process.
<a href="#">Compensation</a>		Compensation is when activities are invoked that undo an undesirable outcome.
<a href="#">Error</a>		The trigger sets or catches errors. It sets an error if the Event is part of a Normal Flow. It reacts to a named error when attached to the boundary of an activity.
<a href="#">Link</a>		Connects an End Event of one Process to an Intermediate Event in another Process.
<a href="#">Message</a>		A message arrives from a participant and triggers an Event. The Process then continues if it is waiting for a message, or changes the flow for exception handling.
<a href="#">Rule</a>		This trigger is only used for exception handling. This event is triggered when a Rule becomes True. A Rule is an expression that evaluates some Process data.
<a href="#">Timer</a>		A specific time-date or cycle is set that triggers an Event. It can act as a delay mechanism if used within the main flow. If used for exception handling, it changes the Normal Flow into an Exception Flow.
End Events		
End Event		Ends a process flow.
<a href="#">Cancel</a>		The type of End is used within a Transaction Sub-process. It indicates that the Transaction should be cancelled and triggers a Cancel Intermediate Event attached to the Sub-process boundary. It also indicates that a Transaction Protocol Cancel message should be sent to any Entities involved in the Transaction.

Element	Palette Icon	Description
<a href="#">Compensation</a>		This End indicates that a Compensation is necessary. The Compensation identifier triggers an intermediate Event when the Process is rolling back.
<a href="#">Error</a>		A named Error should be generated. This Error is caught by an Intermediate Event within the Event Context.
<a href="#">Link</a>		A Link is a mechanism for connecting the end of one process to the start of another.
<a href="#">Message</a>		A message is sent to a participant at the conclusion of the process.
<a href="#">Terminate</a>		All activities in the Process should be ended immediately. The Process is ended without compensation or event handling.
Tasks		
<a href="#">Task</a>		This is an activity that is performed within a business process.
Loop Task		The attributes of Tasks and Sub- processes determine if they are repeated or performed once. There are two types of loops: Standard and Multi-Instance. The looping indicator is displayed at the bottom-center of the activity.
Parallel Multiple Instance Loop Task		This refers to parallel multiple instances of the activities. Activities that are Parallel Multi-Instance have a parallel marker placed in the bottom center of the activity.
Sequential Multiple Instance Loop Task		This refers to sequential multiple instances of the activities. Activities that are sequential multi-Instance have a parallel marker placed in the bottom center of the activity.
Embedded Sub-Process		
<a href="#">Embedded Sub-Process</a>		An Embedded (or nested) Sub-process is an activity that contains other activities (a Process). The Process within the Process is dependent on the parent Process for instigation and has visibility to the parent's global data. No mapping of data is required.
Embedded Sub-Process (Collapsed)		Select this icon to place a collapsed embedded sub-process in the Diagram View
Ad Hoc Embedded Sub-process		An Ad Hoc Process is a group of activities that have no pre-definable sequence relationships. Activities within the Process are disconnected from each other. During execution of the Process, any one or more of the activities may be active and they can be performed in almost any order or frequency.
Loop Embedded Sub-process		The attributes of Tasks and Sub- processes will determine if they are repeated or performed once. There are two types of loops: Standard and Multi- Instance. A small looping indicator is displayed at the bottom- center of the activity.
Parallel Multiple Instance Embedded Sub-process		The attributes of Tasks and Sub- processes determine if they are repeated or performed once. A small parallel indicator is displayed at the bottom-center of the activity.

Element	Palette Icon	Description
Serial Multiple Instance Embedded Sub-process		The attributes of Tasks and Sub- processes determine if they are repeated or performed once. A small parallel indicator is displayed at the bottom-center of the activity.
Transaction Embedded Sub-process		A Sub-process, either collapsed or expanded, can be set as being a Transaction, which has a special behavior that is controlled through a transaction protocol (such as BTP or WS-Transaction). The boundary of the activity is double-lined to indicate that it is a Transaction.
Independent Sub-Process		
<a href="#">Independent Sub-Process</a>		An independent Sub-process element is an activity within a Process that calls to another process that exists within a business process definition diagram.
Loop Independent Sub-process		The attributes of Tasks and Sub- processes will determine if they are repeated or performed once. There are two types of loops: Standard and Multi- Instance. A small looping indicator is displayed at the bottom- center of the activity.
Parallel Multiple Instance Independent Sub-process		The attributes of Tasks and Sub- processes determine if they are repeated or performed once. A small parallel indicator is displayed at the bottom-center of the activity.
Serial Multiple Instance Independent Sub-process		The attributes of Tasks and Sub- processes determine if they are repeated or performed once. A small parallel indicator is displayed at the bottom-center of the activity.
Transaction Independent Sub-process		A sub-process, either collapsed or expanded, can be set as being a Transaction, which has a special behavior that is controlled through a transaction protocol (such as BTP or WS-Transaction). The activity has a double border to indicate that it is a Transaction.
Gateways		
Gateway		This symbol displays decisions, merges, forks, and joins in the process flow. They control how Sequence Flows interact as they converge and diverge within a process. You can set the <a href="#">Gateway Control Types</a> of a gateway and change the logic specified by it.
<a href="#">Complex</a>		Decision: This expression determines which output flow is taken from multiple Sequence Flow names. Merge: You specify a complex flow condition referencing incoming Sequence Flow names or process data coming into a gateway. This expression determines when the task starts.
<a href="#">Data-Based</a>		These are the most common gateways used. A data token traverses the Process Flow arriving at the gateway. It can only go out on one flow. This control type is represented by either a diamond with an "x" in the middle or blank diamond shape.
<a href="#">Event-Based</a>		Decision: This represents a branching point where the alternatives are based on an event occurring at that point. Merge: The exclusive merge models data-based or event-based merges. Only one of the many inputs is chosen as the output.









Element	Palette Icon	Description
<a href="#">Inclusive</a>		Decision: One or more of the outgoing Sequence Flows may be taken. A default flow must be specified at this point, there cannot be zero output flows.  Merge: A process flow continues when it receives the first input signal from the input Sequence Flow. If other signals arrive after that, they are not used.
<a href="#">Parallel</a>		Fork: All Sequence Flows out of this gateway are taken.  Join: This gate must receive input signals from all input Sequence Flows. The process flow does not continue until it receives all signals.
Sequence Flows		
<a href="#">Sequence Flow</a>		A sequence flow shows the sequence of processes in an organization. You can use the sequence flow lines to connect events, activities, and gateways in pools or lanes. The <a href="#">Sequence Flow</a> has five different designations that can be set using the <a href="#">Sequence Flow Property View</a> . Double-click the Sequence Flow to open the Sequence Flow Properties dialog.
Conditional Flow		A conditional flow is evaluated at runtime to determine whether or not the flow is used. If the conditional flow is outgoing from an activity, then the Sequence Flow has a mini-diamond at the beginning of the line. If the conditional flow is outgoing from a Gateway, then the line does not have the diamond.
Default Flow		For Data-Based Exclusive Decisions or Inclusive Decisions, one type of flow is the Default Condition flow. This flow is used only if all other outgoing conditional flows are not true at runtime. These Sequence Flows have a diagonal slash added to the beginning of the line. You would add a Default Conditional Flow marker to a Sequence Flow for two types of decision: Data-based Exclusive and Inclusive Decisions. This flow is used only if all the other outgoing conditional flows are not true at runtime.
Exception Flow		Exception Flows occur outside the normal flow of the Process and it is based upon an Intermediate Event that occurs during the performance of the Process.
Message Flows		
<a href="#">Message Flow</a>		Shows the model order of processes between organizations (i.e. between pools).
Association		
Association		An Association is used to associate information and artifacts with events and activities
Association to Target		The Association connection flows from the source to the target.
Association from Target		The Association connection flows from the target to the source.
Association to/from Target		The Association connection indicates a flow in both directions.



Element	Palette Icon	Description
Pools		
Pool (Horizontal)		This pool is drawn as a rectangular region placed horizontally. A lane is a subpartition within a pool and extends the entire length of the pool. A pool represents an organization, function, application, class, or an entity.
Pool (Vertical)		This pool is drawn as a rectangular region placed vertically. It has the same characteristics as the horizontal pool.
Lanes		
Lanes		Lanes organize and categorize activities. When you place a process in a pool or lane you specify who is doing what. If you place an event in a lane you specify where that event occurs. When you place a gateway in a lane you specify where a decision is made or who makes it.
Nested Lane		You can place lanes within existing lanes with this object.
Artifacts		
Data Object		Data objects provide information about how documents, data, and other objects are used and updated in a Process. They represent data so are defined by a combination of entities or classes.
Group		Use the Group symbol to visually organize activities.
Annotation		Textual annotation allows you to provide additional facts and details about an element.
<a href="#">Off-Page Connector</a>		If a process model extends beyond the length of one printed page you can use an Off-Page Connector to show how Sequence Flow connections extend across the page breaks.







## Conceptual Objects palette

This palette appears in the Diagram Area when you open or create a Conceptual Model diagram. It is not available if a Business Process Model is open. If an element has additional options available, a drop-down menu appears to the right of the icon and element name in the palette. For example, if you click the Relationship element, additional relationship types are available.

Artifact	Palette Icon	Description
<a href="#">Subject Area</a>		Describes the broad term of the business. It can be used by itself as a model object and/or as a grouping mechanism containing business entities.
<a href="#">Business Entities</a>		"Thing" of the business/organization containing other business entities or elements, for example, inventory.
<a href="#">Business Attributes</a>		A property of a business entity, for example, an employee identification number. You can copy and paste an attribute from one Business Entity to another within the same workspace.
<a href="#">Interaction</a>		Relationship between two elements representing an action or process or transaction. Interactions can be created between different types.
Group		A graphical object to <i>visually</i> show that items are grouped together.
Relationship		
<a href="#">Relationship</a>		Relationship between two elements representing a loose couple. Relationships can only be created between conceptual modeling elements of the same type. A warning dialog opens if you try to create a relationship between different types.
Many-to-Many		Denotes that many components are related to many components.
Many-to-One		Denotes that many components are related to one component.
One-to-Many		Denotes that one component is related to many components.
Group		
Group		A graphical object to <i>visually</i> show that items are grouped together.

## References Objects palette







The Reference Object Palette displays the four main reference objects as well as the Link and Usage connectors. Domains are not visualized on diagrams so the Domain element icon is not available on the Reference Object's palette.

Reference Object	Palette Icon	Definition
<a href="#">Business Element</a>		A singular element of the business that can be bound to different business attributes across conceptual models. A Business Element can be used to seed business attributes in a business entity.
<a href="#">Business Rule</a>		A business rule is a policy, practice, or formula related to the operation and enforcement of business practices.
<a href="#">Business Unit</a>		A business unit is an organizational area within or external to an enterprise.
<a href="#">Stewards</a>		A steward is a person or organization responsible to, or associated with a model element.
Links		
Link		This link displays high-level views of information requirements. This type is used to simply relate objects together. The link you create is labeled "conceptual".
Usage		When you select this option you create a link that enables you to designate a usage type: create, read, update, or delete database records. The connection you create is labeled "usage"

## External Data Objects palette













You can use an External Data Object (EDO) in a diagram for reference or for data flow diagramming. You can then link to External Data Objects with a specific business process or task.

There are two different types of EDOs: Logical and Physical. The Logical types are entities and attributes. The Physical types are tables and views.

Type	Palette Icon	Description
Entity		A set of distinguishable objects that can be represented in a database.
Table		A set of data in a database.
View		A view of the data, usually consists of a subset of the tables in the database.
Data Store		A repository for data.
Data Feed		A shell for data containment.
Report		A text file
Flat File		A file containing records, one record per line. Fields may have a fixed width with padding, or delimited by white space, tabs, commas (CSV), or other characters. There are no structural relationships.

## Drawing Shapes palette

All drawing shapes can be resized, formatted, and labeled. You can also format the shapes to be either shadowed or transparent.

Type	Palette Icon	Description
Rectangle		Rectangle is drawn as a box with 90 degree angles.
Rounded Rectangle		Rectangle drawn with rounded corners.
Circle		Drawn as 360 degree circle. Can be resized to an oval.
Triangle		Drawn as a standard isosceles triangle.
Diamond		Standard diamond shape.
Pentagon		Standard five-sided pentagon.
Hexagon		Standard six-sided hexagon.
Octagon		Standard eight-sided octagon.
Cylinder		Standard cylinder shape.
Text Label		A text label is a non-BPMN object that is pure text, without a tail or bracket. You can add borders to the label, and change the color and width of those borders.
Line		A line can be used between two drawing shape objects.
Annotation		A textual annotation allows you to provide additional facts and details about a shape.

### Using the palette

You use the Palette to place objects in the Diagram View. You have the option of expanding or minimizing the palette view.

#### Expanding the Palette View

You can expand or collapse this view. If you want to expand it, click the arrow indicator located at the top of the palette. Also, if you place the cursor anywhere over the palette when it is minimized, it automatically expands.



## Placing elements in a diagram

When you place an element from the Palette in the Diagram View a new element is created in the diagram and in the Model View tree.

**NOTE:** If you create an element from the Model View tree, a graphical representation of that element is not created on a diagram until a diagram is created and you drag the element from the tree to the diagram.

1. Select the element you want to use from the palettes.

**NOTE:** Some items on the palette have a drop-down indicator. Click this to gain access to additional selections that are related to the selected element.

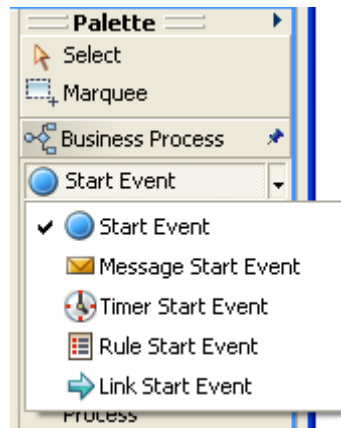

2. Click anywhere in the Diagram View.

Each time you click in the Diagram View, an element is placed on the diagram. Notice that the cursor is in multi-drop mode .

3. Press ESC to disable the multi-drop mode. The cursor returns to its normal mode ().

**NOTE:** You can also disable the multi-drop mode by right-clicking in the element. The shortcut menu opens and once you close this menu you are no longer in multi-drop mode.

## Toolbars

By using the application toolbars you can navigate the most commonly used functionality in ER/Studio BA. You can also move and dock toolbars to further optimize your workspace. ER/Studio BA has the following toolbars:

Toolbar	Description
<a href="#">Business Process Objects Toolbar</a>	Contains the notation elements used when creating business process models.
<a href="#">Conceptual Objects Toolbar</a>	Contains the five notation elements used when creating conceptual models.
<a href="#">Reference Objects Toolbar</a>	Contains the icons representing the four reference objects used in ER/Studio BA.
<a href="#">External Data Objects Toolbar</a>	Contains the available data object icons that represent different types of data.
<a href="#">Drawing Shapes Toolbar</a>	Contains drawing shapes, text labels, lines and annotation elements.
<a href="#">Repository Toolbar</a>	Commands used to interface with the ER/Studio Repository, such as logging in and logging out of the Repository, and checking in and checking out workspaces and objects.
<a href="#">Formatting Toolbars</a>	Commands used to format elements in the Diagram View.
<a href="#">Layout and Alignment Toolbar</a>	Commands used to align and layout elements in the Diagram View.
<a href="#">Standard Toolbar</a>	Contains the standard application tools such as saving, printing, and undo-redo.

### Business Process Objects toolbar









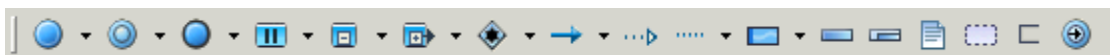

You can use the commands on this toolbar for placing business process elements in a diagram. These commands are also available on the [Palette](#) which is available when you create a new diagram or open an existing diagram.







You have the ability to show and hide this toolbar using the View main menu. By default, the Business Process Toolbar appears in the application once you have created a diagram. Do the following to hide this toolbar:

**NOTE:** Not all objects appear on the toolbar. A drop-down arrow appears to the right of the element icon, indicating that additional selections are available.

1. On the main menu, click View > Toolbars.
2. From the pull-right menu, select Business Process Objects. The toolbar is now hidden. The table below lists each command, its representative icon, and a brief description of each command.







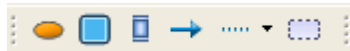

Command	Icon	Description
Start Event		Starts a process flow. In terms of Sequence Flow, the Start Event starts the flow of the Process, so it won't have any incoming Sequence Flows. Click the drop-down arrow to gain access to the Start Event trigger that indicates how the Process starts: Message, Timer, Rule, Link, or Multiple.
Intermediate Event		This event happens during the course of a process event. Click the drop-down arrow to gain access to the Intermediate Event trigger that indicates how the Process proceeds: Cancel, Compensation, Error, Link, Message, Rule, or Timer.
End Event		This event ends a process flow. Click the drop-down arrow to gain access to the End Event trigger that indicates how the Process ends: Cancel, Compensation, Error, Link, Message, or Terminate.
Task		This is an activity that is performed within a business process. Click the drop-down arrow to gain access to additional tasks: Loop Task, Parallel Multiple Instance Loop Task, and Sequential Multiple Instance Loop Task.
Embedded Sub-process		An Embedded (or nested) Sub-process is an activity that contains other activities (a Process). The Process within the Process depends on the parent Process for instigation and has visibility to the parent's global data. No mapping of data is required. Click the drop-down arrow to gain access to additional Embedded Sub-processes: Embedded Sub-Process (Collapsed), Ad hoc, Loop, Parallel Multiple Instance Loop, Sequential Multiple Instance, and Transaction.
Independent Sub-process		An independent Sub-process is an activity within a Process that calls to another Process that exists within a business process definition diagram. Click the drop-down arrow to gain access to additional Independent Sub-processes: Loop, Parallel Multiple Instance Loop, Sequential Multiple Instance, and Transaction.
Gateway		This symbol displays decisions, merges, forks and joins in the process flow. They control how Sequence Flows interact as they converge and diverge within a process. You can set the <a href="#">Gateway Control Types</a> of a gateway and change the logic specified by it. Click the drop-down arrow to gain access to additional gateways: Complex, Data- Based, Event-Based, Inclusive, and Parallel.
Sequence Flow		A Sequence Flow shows the sequence of processes in an organization. You can use the sequence flow lines to connect events, tasks, activities, and gateways in pools or lanes. Click the drop-down arrow to gain access to additional Sequence Flows: Conditional, Default, and Exception.
Message Flow		Shows the order of processes between organizations (i.e. between pools).
Association		An Association is used to associate information and artifacts with events and activities. Click the drop- down to gain access to additional Associations: Association from Target, Association to Target, and Association to/from Target.
Pool (Horizontal)		This pool is drawn as a rectangular region placed horizontally and a lane is a subpartition within a pool and extends the entire length of the pool. A pool represents an organization, function, application, class, or an entity. When you place a process in a pool or lane you specify who is doing what. If you place an event in a pool or lane you specify where that event occurs. When you place a gateway in a pool or lane you specify where a decision is made or who makes it.

Command	Icon	Description
Pool (Vertical)		This pool is drawn as a rectangular region placed vertically and a lane is a subpartition within a pool and extends the entire length of the pool. A pool represents an organization, function, application, class, or an entity. When you place a process in a pool or lane you specify who is doing what. If you place an event in a pool or lane you specify where that event occurs. When you place a gateway in a pool or lane, you specify where a decision is made or who makes it.
Lane		A lane is a subpartition within a Pool and extends the entire length of the pool, either vertically or horizontally. Lanes are used to organize and categorize activities.
Nested Lane		Lanes can be nested within lanes.
Data Object		Data objects provide information about how documents, data, and other objects are used and updated in a Process. They represent data so are defined by a combination of entities or classes.
Group		Use the Group symbol to visually organize activities.
Annotation		Textual annotation allows you to provide additional facts and details about an element.
Off-Page Connector		This is a graphical object that you can use to indicate to the reader of the diagram to move to the next page.

### Conceptual Objects toolbar

The table below describes the available shapes. Not all objects appear on the toolbar. A drop-down arrow appears to the right of the element icon, indicating that additional selections are available.



Element	Toolbar Icon	Description
Subject Area		A subject area can be a model object or a grouping mechanism containing business entities. Examples of a subject area are a Customer Relationship Management system, or a Point of Sale system.
Business Entity		Elements of a business or organization containing other business entities or elements. Examples of an entity would a customer or a product.
Business Attribute		A business attribute is the property of a business entity. Examples of attributes would be a customer address or an employee identification number.
Interaction		This is the relationship between two elements representing an action, process, or transaction.
Relationship		Displays relationships between two objects representing a loose coupling. The relationships are between two like object types. Click the drop-down arrow to gain access to additional relationships types: many-to-many, many-to-one, and one-to-many.
Group		Use the Group symbol to visually organize activities.





## External Data Objects toolbar

The table below describes the objects available on this toolbar.



Element	Toolbar Icon	Description
Entity		Distinguishable objects that can be represented in a database
Table		A set of data in a database.
Data Store		A data store is a repository for data.
Data Feed		A shell for data containment.
Report		This is a text file.
Flat File		A flat file is a file containing records, one record per line. Fields may have a fixed width with padding, or delimited by white space or tabs or commas (CSV) or other characters. There are no structural relationships.

## Drawing Shapes toolbar

Drawing Shapes are used to provide additional information about the Process. There are nine drawing shapes, a text label, a line, and an annotation. The table below displays the available shapes.



Element	Toolbar Icon	Description
Rectangle		Rectangle is drawn as a box with 90 degree angles. Can be resized.
Rounded Rectangle		Rectangle drawn with rounded corners.
Circle		Drawn as 360 degree circle. Can be resized to an oval.
Triangle		Drawn as a standard isosceles triangle.
Diamond		Standard diamond shape.
Pentagon		Standard five-sided pentagon.
Hexagon		Standard six-sided hexagon.
Octagon		Standard eight-sided octagon.
Cylinder		Standard cylinder.
Text Label		A text label is a non-BPMN object that is pure text, without a tail or bracket. You can add borders to the label, and change the color and width of those borders.
Line		A line can be used between two drawing shape objects. The line is automatically elbowed.
Annotation		Textual annotation allows you to provide additional facts and details about a shape.

## Repository toolbar

You can use the commands on the Repository toolbar to log in and out of the Repository, and check in and out workspaces, diagrams, and objects. The table below lists each command and its representative icon, and provides a brief description of each command.



**NOTE:** The commands on the Repository toolbar will be unavailable until you log in to the Repository. For information on specifying the Repository details, see [Logging In and Out of the Repository](#).

Element	Toolbar Icon	Description
Log In		Logs you into the Repository specified in Window > Preferences > Repository. Users must be defined in the Repository. For information on creating users, see the "Administrator's Reference Guide" in the <i>ER/Studio User Guide</i> .
Log Out		Logs you out of the Repository. When you are not using Repository commands you should log out.
Add Workspace		Copies the local open workspace to the Repository and changes the permissions of the open workspace to read-only.
Get Workspace		Copies the latest version of a workspace in the Repository to local storage. Opens a dialog where you can browse through the Repository for the desired workspace.
Get Latest Version		Updates the local copy of the workspace with the copy that is in the Repository.
Check Out Workspace		Changes the permissions of the workspace to read-write and records in the Repository that this workspace has been exclusively checked out. Other users cannot check out the same workspace simultaneously.
Undo Check Out Workspace		Makes the workspace available for other users to check out. Permissions of the local copy are changed to read- only.
Check In Workspace		Updates the Repository version of the open Workspace and changes the permissions of the local copy to read- only.
Delete Workspace		Deletes the open workspace from the Repository. The local copy of the workspace is not deleted.
Check Out Object(s)		Changes the permissions of the local copy of the selected object(s) to read-write and marks the Repository copy as exclusively checked out. Other users cannot check out the same object(s) simultaneously.
Check In Object(s)		Updates the Repository copy of the selected object with the local object content. You can check in Diagrams and Models using this command.
Change Password		Allows the logged in user to change their Repository account password.

## Formatting toolbars

You can use the commands on the formatting toolbar to format the elements in the Diagram View. You can use this toolbar to format the fonts, as well as the line and background color of any element in the Diagram View. Also, you can hide or show this toolbar in the application.

To format an element:

1. Select an element you want to change, for example a Task.
2. If you want to change this task's background color click the drop-down arrow next to the Change Fill icon (  ) on the Formatting Toolbar. A list of all available colors opens.
3. Select the color you want to use. The task's background color changes and the color list closes.









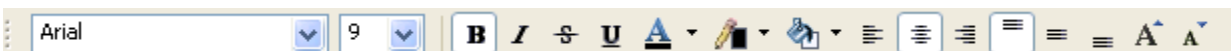

To Hide or Show the Formatting toolbar:

You have the ability to show and hide this toolbar using the View main menu. By default, the Formatting Toolbar automatically appears in the application. Do the following to hide this toolbar:

1. On the main menu, click View > Toolbars.
2. From the pull-right menu, select Formatting. The toolbar is now hidden.

The table below lists each command, its representative icon, and a brief description of each command.



Command	Toolbar Icon	Description
Font Selection		Select a new font from the drop-down list box.
Font Size Selection		Select a new font size from the drop-down list box.
Bold		Applies bold formatting to the selected text.
Italics		Italicizes the selected text.
Strikeout		A line is drawn through the selected text.
Underline		Underlines the selected text.
Change Font Color		A drop-down menu opens a color palette. When you select a color from the palette, the selected text is now displayed in the selected color. This list includes the color labeled "default blue" which is the default color used as the fill color for all Business Process Modeling Notation objects.
Change Line Color		A drop-down menu opens a color palette. When you select a color from the palette, the border of the selected object is now displayed in the selected color.
Change Fill Color		A drop-down menu opens a color palette. When you select a color from that palette, the background of the selected object now displays the selected color.
Left Justify Text		Justifies the text on the left side of the element.
Center Text		Centers the text in the element.



Command	Toolbar Icon	Description
Right Justify Text		Justifies the text on the right side of the element.
Align Text - Top		Aligns the text to the top of an element.
Align Text - Center		Vertically centers the text in an element.
Align Text - Bottom		Aligns the text to the bottom of an element.
Increase Font Size		Each time you click this icon, the font size of the selected object's label is increased by one point size.
Decrease Font Size		Each time you click this icon, the font size of the selected object's label is decreased by one point size.

## Layout and Alignment toolbar

The table below lists each command, its representative icon, and a brief description of each command.



Command	Toolbar Icon	Description
Align Left		Left aligns all selected elements with the selected element.
Align Right		Right aligns all selected elements with the selected element.
Align Top		Aligns all selected elements with the top of the selected element.
Align Bottom		Aligns all selected elements with the bottom of the selected element.
Center Vertically		Centers vertically the selected elements with the center of the selected element.
Center Horizontally		Centers horizontally the selected elements with the center of the selected element.
<a href="#">Distributing Horizontally</a>		Evenly distributes three or more nodes horizontally.
<a href="#">Distributing Vertically</a>		Evenly distributes three or more nodes vertically.
Match Width		All selected elements are resized to match the width of the widest selected element. The selected element has black handles.
Match Height		All selected elements are resized to match the height of the longest selected element. The selected element has black handles
Bring to Front		If multiple elements are stacked, click this icon to bring the selected element to the top or front of the stack.

Command	Toolbar Icon	Description
Send to Back		If multiple elements are stacked, click this icon to drop the selected element to the back of the stack. An outline of the moved element appears in the stack showing the location of the moved element.
Group		Groups two or more selected elements into a single entity that can be moved around a diagram.
Ungroup		Removes the selected grouping. This command is available only if the element selected is in a group.

### Aligning elements in the Diagram view

Take the following steps to align elements within the Diagram View:

1. Select the elements you want to align by holding down the mouse button and drawing a box around the items you want included. All items within the selection box are now marked.
2. Shift+click the element you want to align all other elements with. That element is now highlighted with black boxes instead of hollow boxes.



3. Click the alignment command and all elements are aligned with the selected element. In the example below all elements are centered vertically  with the start event.

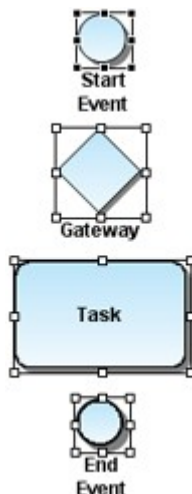

By default, the Layout and Alignment Toolbar automatically appears in the application. Do the following to hide this toolbar:

1. On the main menu, click View > Toolbars.
2. From the pull-right menu, select Layout and Alignment and the toolbar is now hidden.

## Distributing horizontally

Once you place elements in the Diagram View you can evenly distribute those elements horizontally.

1. Select three or more elements in the Diagram View.

**NOTE:** Elements don't have to all be the same (i.e., all tasks or all reference objects).

2. Click  and the selected elements are spaced equidistantly from each other on a horizontal plane.

**NOTE:** Only the spacing between the elements is changed, not the vertical placement of the elements in the diagram.

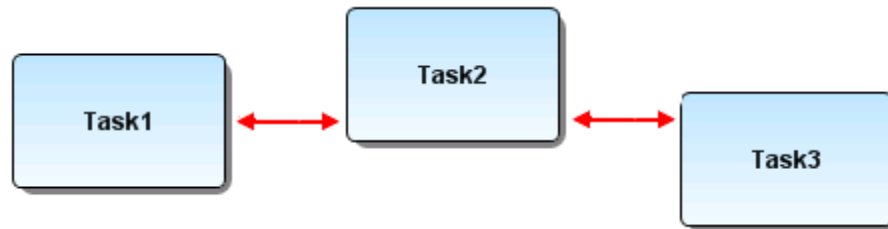

## Distributing vertically

Once you place elements in the Diagram View you can evenly distribute those elements vertically.

1. Select three or more elements in the Diagram View.

**NOTE:** Elements don't have to all be the same (i.e., all tasks or all reference objects).

2. Click  and the selected elements are spaced equidistantly from each other on a vertical plane.



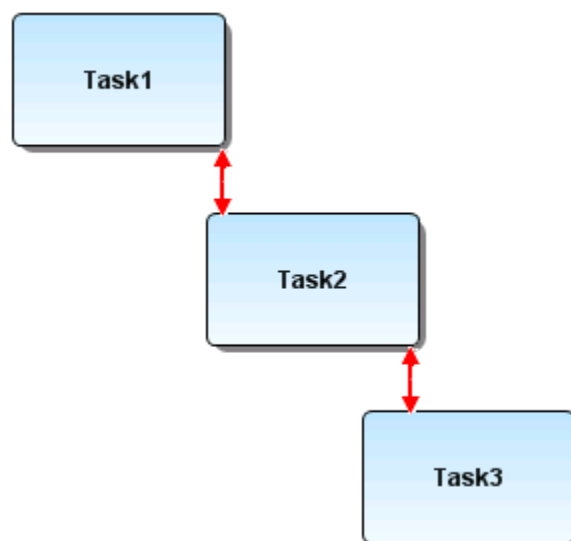



**NOTE:** Only the spacing between the elements is changed, not the horizontal placement of the elements in the diagram.



## Reference Objects toolbar

You can create a link between elements and add a reference object to the Diagram View from the Reference Objects palette. The table below lists each object, its representative icon, and a brief description of each object.









Command	Toolbar Icon	Description
Business Element		A singular element of the business that can be bound to different business attributes across conceptual models. Can be used to seed business attributes in a business entity.
Business Rule		A business rule is a policy, practice, or formula related to the operation and enforcement of business practices.
Business Unit		A business unit is an organizational area within or external to an enterprise.
Steward		A steward is a person or organization responsible or associated with a model element.
Link		Display high-level views of information requirements. This type is used to simply relate objects together.
Usage		You can label the function of the connection as create, read, update, or delete database records. All created connections are labeled "usage".

## Standard toolbar





The Standard Toolbar contains the basic tools used in the application. The table below lists the commands, the corresponding icons, and a brief description for each.



Command	Toolbar Icon	Description
Save		Saves the workspace, project, model, and/or diagram.
Print		Opens the Print dialog box, where you can print the open diagram in the active Diagram View.
Export		You can export the Grid Editor and save in the following formats: csv, html, pdf, and rtf.
Cut		When you cut an element, the application removes it from the diagram and places it on a clipboard. You can then paste the cut element in the same Diagram window, a different Diagram window in the same workspace. The cut item remains on the clipboard until you cut or copy another selection.
Copy		When you copy an element, the application leaves it on the diagram and places it on a clipboard. You can then paste the copied element in the same Diagram window, a different Diagram window in the same workspace. The copied item remains on the clipboard until you cut or copy another selection.
Paste		You can paste any cut or copied object into a Diagram window.



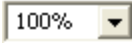

Command	Toolbar_Icon	Description
Delete		When you want to delete an object from the Model View tree, the Delete Elements dialog opens. Click Yes to permanently remove the object from the model and the diagram.  When you want to delete an object from the Diagram View, the Delete Elements dialog opens. Click Delete to permanently remove the selected object from the diagram
Undo		Standard Undo functionality.
Redo		Restores the undo command.
Custom Zoom		Enter a specific percent value for zooming. You can also pick from several default zoom percentage values ranging from 25 percent to 400 percent. You can also select Fit to Page which fits the entire diagram on one page.
Zoom In		Enlarges the active diagram by a preset increment each time you select this option.
Zoom Out		Reduces the active diagram by a preset increment each time you select this option.

## Menus







You can use the ER/Studio BA menus to gain access its features. The menus are: File, Edit, View, Repository, Diagram, Format, Tools, Window, and Help.









Menus provide access to many of ER/Studio BA functions. Click any item on the menu bar to access its submenu items. The table below describes the functions available under the relevant menu bar items:

Menu	Function
<a href="#">File</a>	Create, open, save, and close the current workspace, its models, projects, and diagrams. You can also export/import from this menu.
<a href="#">Edit</a>	You can access functionality for undo, redo, cutting, copying, pasting, deleting, and selecting all. You can also access the Find and Search functionality.
<a href="#">View</a>	Gives you access to the toolbars, and zoom levels in a view.
<a href="#">Repository</a>	Gives you access to Repository operations such as log in and out, and check in and out workspaces and objects.
<a href="#">Diagram</a>	When a diagram is open, the following commands are available: Case Shift, Layout, and Grid. The Show All Links and Update Impact Analysis commands are also available when applicable.
<a href="#">Format</a>	You can use these commands in a diagram to group objects, align objects, or reorder the layers of objects.
<a href="#">Tools</a>	Gives you access to the following commands: Create Diagram from Selected Objects, Create Link, Create Usage, Generate Impact Analysis Diagram, Show Diagrams, Grid Editor, and Reports.
<a href="#">Window</a>	Reset perspectives, Show Views, or Preferences.
<a href="#">Help</a>	You can open ER/Studio BA online documentation, view the licensing information, open the Evaluation Guide, contact support, and open the About dialog.

## File









The table below describes the functions available when you click the File command:

Menu Item	Icon	Description
New - <a href="#">Workspace</a>		Opens the New Workspace dialog where you can create a new workspace, new project, new model, and new diagram.
New - <a href="#">Project</a>		Opens the New Project dialog. You can enter a description of the new project and select where to create the project.
New - <a href="#">Model</a>		Opens the New Model dialog. You can enter a description of the new model and select where to create the model.
New - <a href="#">Diagram</a>		The pull-right menu gives you two options: Business Process or Conceptual. This menu displays the type of diagram to be created. For example if you are creating a new diagram in a Conceptual Model, only Conceptual is available from the pull-right menu. You can enter a description of the new diagram and select where to create the diagram. You can also rename the pool and lane in the New Diagram dialog for a Business Process diagram.
<a href="#">Open Workspace...</a>		Opens the standard windows dialog listing existing workspaces from the file system where you can select one to open. You can also press Ctrl+O.
Close - <a href="#">Workspace</a>		Closes the currently opened workspace.
Close - <a href="#">Diagram</a>		Closes the active diagram only.
Close - <a href="#">All Diagrams</a>		Closes all the opened diagrams. You are prompted to save the diagrams before they are closed.
Close - All Property Views		Closes all the opened Property Views.
Save		This saves everything in the Workspace. You can also press Ctrl+S.
Import - <a href="#">Comma Separated Values (CSV)</a>		You can import large amounts of Reference Objects data in the Comma Separated Value file format into ER/Studio BA.
Import - From ER/Studio Data Architect		<p>Conceptual Objects</p> <p><a href="#">Create New</a>: Select this command to open a wizard where you can select data files to import from ER/Studio Data Architect.</p> <p><a href="#">Update Existing</a>: You can use this option to update an existing data source. All existing objects that match an object you have selected will be updated.</p> <p>External Data Objects</p> <p><a href="#">Create New</a>: Select this command to open a wizard where you can select data files to import from ER/Studio Data Architect.</p> <p><a href="#">Update Existing</a>: You can use this option to update an existing data source. All existing objects that match an object you have selected will be updated.</p>
Import - <a href="#">Microsoft Visio Modell</a>		Diagrams created in Microsoft Visio can be imported.

Menu Item	Icon	Description
Import - <a href="#">Workspace</a>		You can import a compressed workspace.
Export - <a href="#">Workspace</a>		You can export a workspace and store it as a compressed file.
Export - <a href="#">Diagrams</a>		You can export diagrams and save them in the following file formats: jpg, rtf, and pdf.
Export - <a href="#">Grid Editor...</a>		You can export the Grid Editor in the four formats: csv, html, pdf, and rtf
Export		You can export Conceptual Models and diagrams <a href="#">to ER/Studio</a> . If you right-click on a Conceptual Model node (  ) , the command is Export>Model to ERStudio Data Architect.... All elements are included in the export dialog. If you right-click on a Conceptual Model diagram node (  ) , the command is Export Diagram to ER/Studio Data Architect... Only the elements on the selected diagram are available for export.
<a href="#">Print...</a>		Opens the Print dialog. You can also press Ctrl+P.
History		A list of the most recently opened workspaces is displayed. You can set a <a href="#">preference</a> that determines the number of entries that appear in this list.
Exit		Exits the application. A Save Workspace dialog opens asking if you want to save the current workspace.

## Edit

The table below describes the functions available when you click the Edit command:

Menu Item	Icon	Description
Undo		Standard undo functionality.
Redo		Standard redo functionality.
Cut		Moves a selected object to the clipboard and removes it from the diagram display.
Copy		Copies selected items to the clipboard.
Paste		Pastes the data from the clipboard into a diagram.
Delete		Deletes an object from the Diagram View. The deleted object is not placed on the clipboard.
Select All		Selects all objects in the Diagram View.
Select All of Selected Type		All related types on a Diagram View are selected. For example, if you select a start event and your diagram contains start, intermediate and end events, all events are selected.
<a href="#">Finding in Diagram</a>		Opens a dialog where you can search for items by Name and Object Type in the opened diagram. The searched-for item is highlighted in the diagram.
<a href="#">Search...</a>		Opens a dialog for an advanced search of the metamodel. The results of the search appear in a separate Search Results View dialog.
<a href="#">Properties</a>		Opens the Property View dialog for the selected object.

## View

The table below describes the functions available when you click the View command:

Menu Item	Description
Toolbars	Allows you to hide or view the following: <ul style="list-style-type: none"> <li>• <a href="#">Business Process Objects Toolbar</a></li> <li>• <a href="#">Conceptual Objects Toolbar</a></li> <li>• <a href="#">Reference Objects Toolbar</a></li> <li>• <a href="#">External Data Objects Toolbar</a></li> <li>• <a href="#">Drawing Shapes Toolbar</a></li> <li>• <a href="#">Formatting Toolbars</a></li> <li>• <a href="#">Layout and Alignment Toolbar</a></li> </ul>
<a href="#">Zoom Level</a>	Enlarges the active diagram by a preset increment each time you select this option. You can also use the <a href="#">Fit to Page</a> or <a href="#">Custom</a> command.

## Repository

The table below describes the functions available when you click the Repository command:

Menu Item	Description
Log In	Logs you into the Repository specified in Window > Preferences > Repository. Users must be defined in the Repository. For information on creating users, see the "Administrator's Reference Guide" in the <i>ER/Studio User Guide</i> .
Log Out	Logs you out of the Repository. When you are not using Repository commands you should log out.
Workspace	<p>Add Workspace: Copies the local open workspace to the Repository and changes the permissions of the open workspace to read-only.</p> <p>Get Workspace: Copies the latest version of a workspace in the Repository to local storage. Opens a dialog where you can browse through the Repository for the desired workspace.</p> <p>Get Latest Version: Updates the local copy of the workspace with the copy that is in the Repository.</p> <p>Check Out Workspace: Changes the permissions of the workspace to read-write and records in the Repository that this workspace has been exclusively checked out. Other users cannot check out the same workspace simultaneously.</p> <p>Undo Check Out Workspace: Makes the workspace available for other users to check out. Permissions of the local copy are changed to read-only.</p> <p>Check In Workspace: Updates the Repository version of the open Workspace and changes the permissions of the local copy to read- only.</p> <p>Delete Workspace: Deletes the open workspace from the Repository. The local copy of the workspace is not deleted.</p> <p>Check Out Object(s): Changes the permissions of the local copy of the selected object(s) to read-write and marks the Repository copy as exclusively checked out. Other users cannot check out the same object(s) simultaneously.</p> <p>Check In Object(s): Updates the Repository copy of the selected object with the local object content. You can check in Diagrams and Models using this command.</p>
Security	Change Password: Allows the logged in user to change their Repository account password.

## Diagram

The table below describes the functions available when you click the Diagram command:

Menu Item	Description
<a href="#">Case Shift</a>	You can set the case format for all element labels. When you make a selection, all labels in the diagram conform to the new selection. You have three options:  Lower: All text appears in lower case lettering, including the initial letter of each word on the label.  Preserve: All text appears as it was entered in the label.  Upper: All text appears in upper case lettering.
<a href="#">Grid</a>	This pull-right menu contains three additional commands:  Show Grid Lines: The grid lines appear in the Diagram View.  Show Parent Objects as Transparent: When a parent object such as a pool or lane is placed on a diagram, the grid lines appear in the object, i.e. the object is transparent.  Snap Objects to Grid: When an element is placed in the Diagram View, it automatically snaps to the nearest grid. When an element is moved, it also snaps to the nearest grid line.
Layout	Select Curved, Elbowed, or Straight for all connections. The default selection is curved.
Connections	Select this command to display or hide the connections for all or individual objects in the diagram. The connections available on the pull-right menu depends on the type of diagram (either Business Process or Conceptual).
Update Impact Analysis	Instead of generating a new Impact Analysis diagram each time you add links or usages, you can refresh or update your existing diagram to show new connections.

For more information, see [Edit Diagrams](#).





## Format

The table below describes the functions available when you click the Format command.

Menu Item	Description
<a href="#">Align Objects</a>	Gives you access to all of the align and size commands. These commands are also available on the Align Toolbar.
<a href="#">Grouping</a>	Group: Groups two or more selected elements into a single entity that can be moved around a diagram in a block. The Group command is available if two or more elements are selected. Once the items are grouped a bounding box appears around the grouped items.  Ungroup: Removes the selected grouping. This command is available only if the element selected is in a group.
Order	This command gives your access to two functions: <a href="#">Bring to Front</a> and <a href="#">Send to Back</a> .

## Tools

The table below describes the functions available when you click the Tools command.

Menu Item	Icon	Description
<a href="#">Create Diagram from Selected Elements...</a>		You can create new diagrams from existing model objects.
Create Link...		Opens the <a href="#">Create Link</a> wizard.
Create Usage...		Opens the <a href="#">Create Usage</a> wizard.
<a href="#">Impact Analysis Diagram</a>		<a href="#">Generate New Diagram</a> : Creates a diagram that shows a graphical representation of created links or usages. You can also <a href="#">update</a> this diagram.
Show Diagram		When a diagram is closed (i.e., not displayed in the Diagram View), you can select the Show Diagram in model view command to open the highlighted diagram.
<a href="#">Grid Editor...</a>		The Grid Editor is an spreadsheet-like display format that is an alternative to the Model View tree view. This is valuable for large objects or business-related objects, such as business rules. The Grid Editor can be printed or exported as a report.
Reports		<a href="#">Impact Analysis</a> : Opens an impact analysis property view of the selected object. <a href="#">Web Report</a> : You can generate an HTML report on all diagrams in the opened workspace.





## Window

The table below describes the functions available when you click the Window command:

Menu Item	Description
Reset Perspective	Reset the current perspective to the default settings.
Show View	The commands available are: Error Logging: Opens the <a href="#">Error Logging View</a> . Help: Opens online help. Model: Opens the <a href="#">Model View</a> Overview: Opens the <a href="#">Overview Window</a> . Palette: Opens the <a href="#">Palette</a> view in the Diagram View. Search Results: Opens the <a href="#">Search</a> Results view to the right of the Diagram View area.
Preferences...	Opens the <a href="#">Preferences Editor</a> dialog where you can change default settings.

## Help

The table below describes the functions available when you click the Help command:

Menu Item	Icon	Description
Help Contents		Displays the main online help file.
Evaluation Guide		Opens a tutorial which guides you through the initial creation of business process and conceptual models.
Check for Updates		Opens the ER/Studio BA web site where you can download application updates.
Buy Now		Opens the IDERA Product web site where you can purchase IDERA software.
Contact Support		Opens the IDERA Contact Support web site.
Discussion Forums		Opens the IDERA Discussion Forums web site where you can log on and participate in forums with other users.
<a href="#">License Manager</a>		Opens the License Manager dialog.
<a href="#">About ER/Studio BA</a>		Opens the About ER/Studio BA dialog displaying the version and build identification for the current install.

### About ER/Studio BA

The About dialog displays the version number, build identification number for your application, as well as a list of third-party software used in the product. Through this About dialog, you also have access to Feature Details, Plug-in Details, and Configuration Details.

Click **Feature Details** and a dialog opens displaying how ER/Studio BA is built internally. This is for informational purposes only. Click **Plug-in Details** and a dialog opens displaying the following information on all the plug-ins in use:

- Provider
- Plug-in Name
- Version
- Plug-in ID

When you click **Configuration Details** a dialog opens displaying the following information:

- Platform Details
- System Properties
- Features
- Plug-in Registry
- User Preferences
- Current Install Configuration
- Configured Sites
- Configured Features
- Configured Plug-ins

You can copy and save this configuration information to a clipboard. Also, you can view the Eclipse error log in a separate window.



## Shortcut menus

Many of ER/Studio BA windows incorporate shortcut menus to give you another method for quickly accessing application functions. The contents of these menus mirror the application's menu bar functions. To execute shortcut menu options from any selected window, view, dialog, or element do the following:

1. Right-click the selected object to open the applicable shortcut menu.
2. On the shortcut menu, click the menu item.

There are two main areas where shortcut menus are available: [Model View Tree Nodes](#), and [Diagram View](#).







### Model view tree nodes

The following shortcut menus are available:

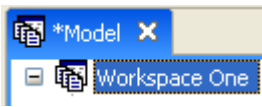
- [Workspace Node](#)
- [Project Node](#)
- [Model Node - Business Process Modeling](#)
- [Model Node - Conceptual Modeling](#)
- [Diagram Node - Business Process Modeling](#)
- [Diagram Node - Conceptual Modeling](#)
- [Lane Elements on the Model View Tree](#)
- [Elements on the Model View Tree](#)
- [Search Results View](#)
- [Grid Editor](#)
- [Error Logging View](#)
- [Reference Objects](#)
- [Reference Object Elements](#)
- [External Data Objects](#)
- [Palette](#)







## Workspace node

The table below describes the functions available when you right-click the Workspace Node in the Model View tree:

Shortcut Menu Item	Icon	Description
New		You can create a new workspace, project, or model from this pull- right menu.
Open Workspace...		Select an existing workspace to open. <b>Note:</b> You can only have one workspace open at a time.
Close		Closes the current workspace. A Save Resource dialog opens asking if you want to save the changes.
Save Workspace		Saves the current workspace. Note that an asterisk appears on the Model View tab each time you make any changes to the workspace and/or its associated projects, models, and diagrams. Once you save the workspace the asterisk is removed. 
Rename		Opens the Rename Workspace dialog where you can enter a new name for the selected workspace. You can also press F2.
<a href="#">Delete</a>		Select Delete and the Confirm Workspace Delete dialog opens asking you to confirm your decision.
Import - From ER/Studio Data Architect		<a href="#">Create New Conceptual Objects</a> : Select this command to open a wizard where you can select data files to import from ER/Studio Data Architect. <a href="#">Update Existing Conceptual Objects</a> : You can use this option to update an existing data source. All existing objects that match an object you have selected will be updated.
Import - <a href="#">Microsoft Visio Model</a>		Opens a wizard that walks you through the importing of a Microsoft Visio model into ER/Studio BA.
<a href="#">Export...</a>		You can export your workspaces in a compressed format which can then be imported into another ER/Studio BA application on another computer.
Repository		When logged in to ER/Studio Repository, you can check in and check out Repository workspaces.
Insert Project/Model		If you have deleted a project or model but did not <a href="#">delete the associated files</a> , you can select this command to “restore” the deleted project or model.
Refresh		Updates the currently displayed information with new data or changes.
<a href="#">Properties</a>		Opens the Property View dialog for the selected workspace.









## Project node

The table below describes the functions available when you right-click the Project Node in the Model View tree:

Shortcut Menu Item	Icon	Description
New		You can create a new project or new model from this pull-right menu.
Close		Closes the open project.
Save Project		Saves the current project.
Rename		Opens the Rename Project dialog where you can rename the project and its owning folder.
Delete		Select Delete and the Confirm Project Delete dialog opens asking you to confirm your decision. You have three options in this dialog: <ul style="list-style-type: none"> <li>• No, I do not want to delete the project.</li> <li>• Yes, and also delete the associated files.</li> <li>• Yes, but do not delete the associated files.</li> </ul>
Links		If you are creating a new link, click Links>New and the <a href="#">Create Link</a> wizard opens. If you are editing an existing link, click <i>Links &gt; Edit</i> . If there are multiple links, the pull-right menu displays a list of the existing links. Click the name on the pull-right and the <a href="#">Edit Link</a> wizard opens. If there is only one link the command is <i>Links &gt; Edit</i> .
Usage (CRUD)		If you are creating a new usage, click <i>Usage &gt; New</i> and the <a href="#">Usages</a> wizard opens. If you want to edit or view an existing usage, click Usage (CRUD)>Edit or View. The Usage (CRUD) tab opens in the Property View for the selected element.
Impact Analysis		You have two commands available from the pull-right menu: You can generate an <a href="#">Impact Analysis Diagram</a> which graphically displays all the associated relationships and elements. You can also show the <a href="#">Impact Analysis Report</a> .
Import - From ER/Studio Data Architect		<a href="#">Create New Conceptual Objects</a> : Select this command to open a wizard where you can select data files to import from ER/Studio Data Architect. <a href="#">Update Existing Conceptual Objects</a> : You can use this option to update an existing data source. All existing objects that match an object you have selected will be updated.
Import - <a href="#">Microsoft Visio Model</a>		Opens a wizard that walks you through the importing of a Microsoft Visio model into ER/Studio BA.
Repository		When logged in to ER/Studio Repository, you can check in and check out Repository objects.
Insert Project/Model		If you have deleted a project or model but did not <a href="#">delete the associated files</a> , you can select this command to "restore" the deleted project or model.
Refresh		Updates the currently displayed information with new data or changes.
<a href="#">Properties</a>		Opens the Property View dialog for the selected project.









## Model node - Business Process Modeling

The table below describes the functions available when you right-click the Model Node in the Model View tree:

Shortcut Menu Item	Icon	Description
New		You can create a new diagram, new model, or new pool from this pull-right menu.
Open/Close		This is a toggle command that closes an open model and vice versa.
Save Model		Saves the open model.
Rename		Opens the Rename Model dialog where you can rename both the model and its folder.
Delete		Select Delete and the Confirm Model Delete dialog opens asking you to confirm your decision. You have three options in this dialog: <ul style="list-style-type: none"> <li>• No, I do not want to delete the model.</li> <li>• Yes, and also delete the associated files.</li> <li>• Yes, but do not delete the associated files.</li> </ul>
Links		If you are creating a new link, click Links>New and the <a href="#">Create Link</a> wizard opens. If you are editing an existing link, click Links>Edit. If there are multiple links, the pull-right menu displays a list of the existing links. Click the name on the pull-right and the <a href="#">Edit Link</a> wizard opens. If there is only one link the command is Link>Edit.
Usage (CRUD)		If you are creating a new usage, click Usage>New and the <a href="#">Usages</a> wizard opens. If you want to edit or view an existing usage, click Usage (CRUD)>Edit or View. The Usage (CRUD) tab opens in the Property View for the selected element.
<a href="#">Grid Editor...</a>		The Grid Editor is a spreadsheet-like display format that is an alternative to the Model View tree view. This is valuable for large objects or business-related objects, such as business rules. Grid Editors can be printed or exported as a report.
Impact Analysis		You have two commands available from the pull-right menu: You can generate an <a href="#">Impact Analysis Diagram</a> which graphically displays all the associated relationships and elements. You can also show the <a href="#">Impact Analysis Report</a> .
Import - <a href="#">Comma Separated Values (CSV)</a>		You can import large amounts of Reference Objects data in the Comma Separated Value file format into ER/Studio BA.
Import - <a href="#">Microsoft Visio Model</a>		Opens a wizard that walks you through the importing of a Microsoft Visio model into ER/Studio BA.
Export		Allows you to export a model to ER/Studio Data Architect.
Repository		When logged in to ER/Studio Repository, you can check in and check out Repository objects.
Insert Model...		If you have deleted a model but did not <a href="#">delete the associated files</a> , you can select this command to “restore” the deleted model.
Refresh		Updates the currently displayed information with new data or changes.
<a href="#">Properties</a>		Opens the Property View dialog for the selected model.







## Model node - Conceptual Modeling

The table below describes the functions available when you right-click the Model Node in the Model View tree:

Shortcut Menu Item	Icon	Description
New		You can create a new diagram, model, Business Entity or Subject Area from this pull-right menu.
Open/Close		This is a toggle command that closes an open model and vice versa.
Save Model		Saves the open model.
Rename		Opens the Rename Model dialog where you can rename both the model and its folder.
Delete		Select Delete and the Confirm Model Delete dialog opens asking you to confirm your decision. You have three options in this dialog: <ul style="list-style-type: none"> <li>- No, I do not want to delete the model.</li> <li>- Yes, and also delete the associated files.</li> <li>- Yes, but do not delete the associated files.</li> </ul>
Links		If you are creating a new link, click Links>New and the <a href="#">Create Link</a> wizard opens. If you are editing an existing link, click Links>Edit. If there are multiple links, the pull-right menu displays a list of the existing links. Click the name on the pull-right and the <a href="#">Edit Link</a> wizard opens. If there is only one link the command is Links>Edit.
Usage (CRUD)		If you are creating a new usage, click Usage>New and the <a href="#">Usages</a> wizard opens. If you want to edit or view an existing usage, click Usage (CRUD)>Edit or View. The Usage (CRUD) tab opens in the Property View for the selected element.
<a href="#">Grid Editor...</a>		The Grid Editor is a spreadsheet-like display format that is an alternative to the Model View tree view. This is valuable for large objects or business-related objects, such as business rules. Grid Editors can be printed or exported as a report.
Impact Analysis		You have two commands available from the pull-right menu: <p>You can generate an <a href="#">Impact Analysis Diagram</a> which graphically displays all the associated relationships and elements.</p> <p>You can also show the <a href="#">Impact Analysis Report</a>.</p>
Import - <a href="#">Comma Separated Values (CSV)</a>		You can import large amounts of Reference Objects data in the Comma Separated Value file format into ER/Studio BA.
Import - <a href="#">From ER/Studio Data Architect</a>		<a href="#">Create New Conceptual Objects</a> : Select this command to open a wizard where you can select data files to import from ER/Studio Data Architect. <a href="#">Update Existing Conceptual Objects</a> : You can use this option to update an existing data source. All existing objects that match an object you have selected will be updated.
Export Model to ER/Studio Data Architect		You can export objects on a Model to ER/Studio Data Architect where the elements in the conceptual diagram map to the logical diagram in ER/Studio Data Architect.
Repository		When logged in to ER/Studio Repository, you can check in and check out Repository objects.
Insert Model		If you have deleted a model but did not <a href="#">delete the associated files</a> , you can select this command to "restore" the deleted project or model.
Refresh		Updates the currently displayed information with new data or changes.
<a href="#">Properties</a>		Opens the Property View dialog for the selected model.



## Diagram node - Business Process Modeling





The table below describes the functions available when you right-click a Business Process Modeling Diagram Node in the Model View tree:

Shortcut Menu Item	Icon	Description
Open/Close		If the diagram is closed, click this command to open the diagram in the Diagram View.
Save Diagram		This command is available if any changes have been made to the open diagram.
Rename		Opens the Rename Diagram dialog.
Delete		Delete the diagram from the Model View tree. A Delete Element dialog opens asking you to confirm the delete action.
<a href="#">Grid Editor...</a>		The Grid Editor is a spreadsheet-like display format that is an alternative to the Model View tree view. This view displays the properties of the selected node. For example the Grid Editor for a lane would displays all the elements in the lane, the element's names, and their descriptions. This is valuable for large objects or business-related objects, such as business rules. Grid Editors can be printed or exported as a report.
Export		You can export the opened diagram and save it in the following formats: csv, html, pdf, and rtf. Note: This command is available only if the diagram is opened in the Diagram View area.
Import <a href="#">Comma Separated Values (CSV)...</a>		You can import large amounts of Reference Objects data in the Comma Separated Value file format into ER/Studio BA.
Export Diagram to ER/Studio Data Architect		You can export objects on a Model to ER/Studio Data Architect where the elements in the business process diagram map to the logical diagram in ER/Studio Data Architect.
Repository		When logged in to ER/Studio Repository, you can check in and check out Repository objects.
Refresh		Updates the currently displayed information with new data or changes.
<a href="#">Properties</a>		Opens the Property View dialog for the selected diagram.

## Diagram node - Conceptual Modeling





The table below describes the functions available when you right-click a Conceptual Model Diagram Node in the Model View tree:

Shortcut Menu Item	Icon	Description
Open/Close		If the diagram is closed, click this command to open the diagram in the Diagram View.
Rename		Opens the Rename Diagram dialog.
Delete		Delete the diagram from the Model View tree. A Delete Element dialog opens asking you to confirm the delete action.
<a href="#">Grid Editor...</a>		The Grid Editor is a spreadsheet-like display format that is an alternative to the Model View tree view. This view displays the properties of the selected node. This is valuable for large objects or business-related objects, such as business rules. Grid Editors can be printed or exported as a report.

Shortcut Menu Item	Icon	Description
Import <a href="#">Comma Separated Values (CSV)</a>		You can import large amounts of Reference Objects data in the Comma Separated Value file format into ER/Studio BA.
<a href="#">Export Diagram to ER/Studio Data Architect</a>		You can export elements on a Conceptual Model diagrams to ER/Studio Data Architect application.
Repository		When logged in to ER/Studio Repository, you can check in and check out Repository objects.
Refresh		Updates the currently displayed information with new data or changes.
<a href="#">Properties</a>		Opens the Property View dialog for the selected diagram.







### Lane elements on the Model view tree

The table below describes the functions available when you right-click a lane on the Model View tree:

Shortcut Menu Item	Icon	Description
New		This command is available only for pools and lanes in the Model View tree. When you select this command a pull-right is available to create a new lane.
Move Lane...		Opens a Move Lane dialog where you can move lanes up or down in the Model View tree.
Rename		Makes the node name editable. If the diagram is open, it also renames the element in the Diagram View. You can also click F2.
Delete		This command opens the Delete Elements dialog asking if you are sure you want to delete the selected elements. Clicking Yes removes the elements from the project and any diagrams (both in the Model View tree and in the Diagram View) on which the elements appear.
Links		If you are creating a new link, click Links>New and the <a href="#">Create Link</a> wizard opens. If you are editing an existing link, click Links>Edit. If there are multiple links, the pull-right menu displays a list of the existing links. Click the name on the pull-right and the <a href="#">Edit Link</a> wizard opens. If there is only one link the command is Links>Edit.
Usage (CRUD)		If you are creating a new usage, click Usage>New and the <a href="#">Usages</a> wizard opens. If you want to edit or view an existing usage, click Usage (CRUD)>Edit or View. The Usage (CRUD) tab opens in the Property View for the selected element.
Diagram Usage		A pull-right menu lists the diagram(s) the select element appears in. This allows you to quickly locate and open the diagram where the element appears. If the element appears on more than ten diagrams the More... option appears opening a dialog listing all diagrams.
Impact Analysis		You have two commands available from the pull-right menu: You can generate an <a href="#">Impact Analysis Diagram</a> which graphically displays all the associated relationships and elements. You can also show the <a href="#">Impact Analysis Report</a> .
Refresh		Updates the currently displayed information with new data or changes.
<a href="#">Properties</a>		Opens the Property View dialog for the selected element.

## Elements on the Model view tree

The table below describes the functions available when you right-click an element on the Model View tree:

Shortcut Menu Item	Icon	Description
New		Creates a new element which is placed in the Model View tree. The list of elements available on the pull-right menu depends on the element you right-click on. This command is not available for all elements.
<a href="#">Create Diagram from Selected Elements...</a>		You can create new diagrams from existing model objects.
Rename		Makes the node name editable. If the diagram is open, it also renames the element in the Diagram View. You can also click F2.
Delete		This command opens the Delete Elements dialog asking if you are sure you want to delete the selected elements. Clicking Yes removes the elements from the project and any diagrams (both in the Model View tree and in the Diagram View) on which the elements appear.
<a href="#">Create Mapping/Edit Mapping</a>		If you right-click on a Subject Area you can map to one or more Conceptual Model diagrams or Business Entities.
Diagram Mappings		This command is available once you have mapped a diagram to a Subject Area. When it is selected a pull-right menu opens displaying the mapped diagram(s).
Diagram Usage		A pull-right menu lists the diagram(s) the select element appears in. This allows you to quickly locate and open the diagram where the element appears. If the element appears on more than ten diagrams the More... option appears opening a dialog listing all diagrams.
<a href="#">Grid Editor...</a>		The Grid Editor is a spreadsheet-like display format that is an alternative to the Model View tree view. This is valuable for business-related objects, such as business rules. Grid Editors can be printed or exported as a report.
Links		If you are creating a new link, click Links>New and the <a href="#">Create Link</a> wizard opens. If you are editing an existing link, click Links>Edit. If there are multiple links, the pull-right menu displays a list of the existing links. Click the name on the pull-right and the <a href="#">Edit Link</a> wizard opens. If there is only one link the command is Links>Edit.
Usage (CRUD)		If you are creating a new usage, click Usage>New and the <a href="#">Usages</a> wizard opens. If you want to edit or view an existing usage, click Usage (CRUD)>Edit or View. The Usage (CRUD) tab opens in the Property View for the selected element.
Impact Analysis		You have two commands available from the pull-right menu: You can generate an <a href="#">Impact Analysis Diagram</a> which graphically displays all the associated relationships and elements. You can also show the <a href="#">Impact Analysis Report</a> .
Refresh		Updates the currently displayed information with new data or changes.
<a href="#">Properties</a>		Opens the Property View dialog for the selected element.





## Search Results view





The table below describe the functions available when you right-click a row or cell in the Search Results view.

Shortcut Menu Item	Description
Name, Type, Description, Notes	By default, all columns are displayed. These are toggle settings, so you can select or deselect which columns you want displayed.
Open Search Dialog	Opens the Search dialog so you can specify a new search or modify your existing search.
Find In	Opens a pull-right menu with the following commands: Active Diagram: This command finds and highlights the selected search item in the active diagram. All Diagrams: This command searches for the selected search item on all diagrams in the model. The Diagram Usage dialog opens displaying all the diagrams where the element appears. Model View: Finds the selected search item in the Model View tree.
Run Previous Search	The pull-right menu displays the previous searches. Up to ten searches are listed. You can also select the Clear History option.
Filter Results	Opens the Search Results Filter dialog. Use this to refine the search. You can select which types of objects you don't want to see in the Results view. You can expand or collapse the tree. You can also select or deselect all the tree node items.
Customize Columns	Opens the Customize Columns dialog where you select the columns you want displayed in the Search Results view.
Properties	Opens the Property View for the selected search item.

## Grid editor









The table below describes the functions available when you right-click a row or cell in the Grid Editor:

Shortcut Menu Item	Icon	Description
Name		Select this command to display the Name column in the Grid Editor.
Data Type		Select this command to display the Data Type column in the Grid Editor.
Type		Select this command to display the Type column in the Grid Editor.
E-Mail Address		Select this command to display the E-Mail Address column in the Grid Editor.
Responsibility		Select this command to display the Responsibility column in the Grid Editor.
Description		Select this command to display the Description column in the Grid Editor.
Notes		Select this command to display the Notes column in the Grid Editor.
Sort Ascending by Name		Reorders the selected column by sorting from A to Z.
Sort Descending by Name		Reorders the selected column by sorting from Z to A.

Shortcut Menu Item	Icon	Description
Customize Columns		Opens the Customize Columns dialog where you can customize the Grid Editor to display only selected columns. Deselect the columns you want to hide in the view and click OK. The selected columns no longer appear and the tab displays the notation that you have customized this Grid Editor.
Delete		Deletes a selected item. A warning dialog opens asking if you are sure you want to delete the selected item. If you select Yes, the item is removed not only from the Grid Editor, but also from the workspace.
Refresh		Updates the currently displayed information with new data or changes. You can also press F5.
<a href="#">Properties</a>		Opens the Property View dialog for the selected element.

### Error Logging view

You can open the Error View by clicking **Window > Show View > Error Logging** on the main menu. The table below describes the functions available when you right-click the Error View:

Shortcut Menu Item	Icon	Description
Copy		Copies the event details to the clipboard where you can save or print it.
Clear Log Viewer		Clears all error details from the Log Viewer.
Delete Log		The action permanently deletes all log events. When you select this action a warning dialog opens asking you to confirm the delete action.
Open Log		Opens the current log file in Notepad.
Restore Log		Restores all the error details that were cleared using the Clear Log Viewer command.
Export Log		You can export the current log to another file location and save it as a .log file.
Import Log		All existing files with the .log extension are listed. The selected imported log file opens the Error View.
Event Details		Opens the Event Details dialog displaying the date, severity level, error message, the exception stack trace, and session data. You can copy the event details to the clip board by clicking  .

## Reference Objects

The table below describes the functions available when you right-click the top level Reference Objects node in the Model View tree:

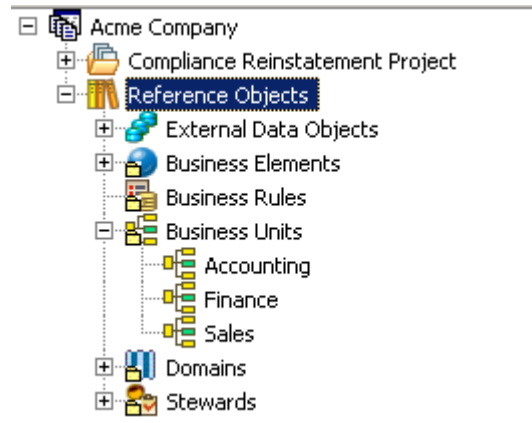



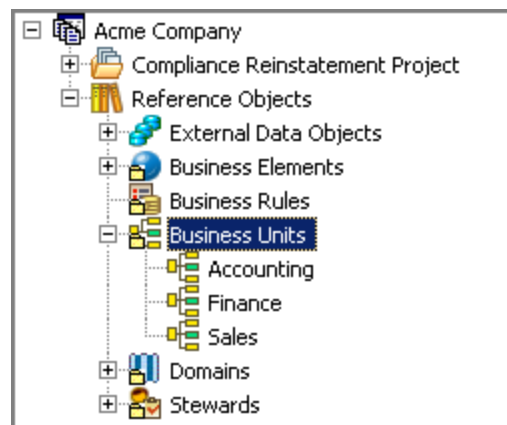

Shortcut Menu Item	Icon	Description
New		Create a new Business Element, Business Rule, Business Unit, Domain, or Steward. The available command depends on which node you select. For example if you right-click Business Rules, the command is New Business Rule.
Save Project		Saves the current project.
<a href="#">Grid Editor...</a>		The Grid Editor is a spreadsheet-like display format that is an alternative to the Model View tree view. This is valuable for large objects or business-related objects, such as business rules. Grid Editors can be printed or exported as a report.
Refresh		Updates the currently displayed information with new data or changes.
<a href="#">Properties</a>		Opens the Property View dialog for the selected reference object.

## Reference Object nodes



The table below describes the functions available when you right-click a Reference Objects Node (for example Business Units) in the Model View tree:





Shortcut Menu Item	Icon	Description
New		Create a new Business Element, Business Rule, Business Unit, Domain, or Steward. The available command depends on which node you select. For example if you right-click Business Rules, the command is New Business Rule.
<a href="#">Create Diagram from Selected Elements...</a>		You can create new diagrams from existing model objects.
<a href="#">Grid Editor...</a>		The Grid Editor is a spreadsheet-like display format that is an alternative to the Model View tree view. This is valuable for large objects or business-related objects, such as business rules. Grid Editors can be printed or exported as a report.
Import <a href="#">Comma Separated Values (CSV)</a>		You can import large amounts of Reference Objects data in the Comma Separated Value file format into ER/Studio BA.
Refresh		Updates the currently displayed information with new data or changes.
<a href="#">Properties</a>		Opens the Property View dialog for the selected reference object.

## Reference Object elements





Once you have created a Reference Object element, a shortcut menu for the newly-created Reference Object is available:

Shortcut Menu Item	Icon	Description
<a href="#">Create Diagram from Selected Elements</a>		You can create new diagrams from existing model objects.
Rename		Makes the node name editable. If the diagram is open, it also renames the element in the Diagram View. You can also click F2.
Delete		This command opens the Delete Elements dialog asking if you are sure you want to delete the selected elements. Clicking Yes removes the elements from the project and any diagrams (both in the Model View tree and in the Diagram View) on which the elements appear.
Links		If you are creating a new link, click Links > New and the <a href="#">Create Link</a> wizard opens. If you are editing an existing link, click Links>Edit. If there are multiple links, the pull-right menu displays a list of the existing links. Click the name on the pull-right and the <a href="#">Edit Link</a> wizard opens. If there is only one link the command is Links > Edit.
Usage (CRUD)		If you are creating a new usage, click Usage>New and the <a href="#">Usages</a> wizard opens. If you want to edit or view an existing usage, click Usage (CRUD)>Edit or View. The Usage (CRUD) tab opens in the Property View for the selected element.
Diagram Usage		A pull-right menu lists the diagram(s) the select element appears in. This allows you to quickly locate and open the diagram where the element appears. If the element appears on more than ten diagrams the More... option appears opening a dialog listing all diagrams.
Bindings...		This command is available when you right-click on a Business Element or Domain. It opens the property editor for the selected element where you can create or edit bindings.
Impact Analysis		You have two commands available from the pull-right menu: You can generate an <a href="#">Impact Analysis Diagram</a> which graphically displays all the associated relationships and elements. You can also show the <a href="#">Impact Analysis Report</a> .

Shortcut Menu Item	Icon	Description
<a href="#">Create as Pool</a>		This command is available only for the Business Unit and Stewards.
Refresh		Updates the currently displayed information with new data or changes.
<a href="#">Properties</a>		Opens the Property View dialog for the selected element.







## External Data Objects

The table below describes the functions available when you right-click the top-level External Data Objects Node in the Model View tree:

Shortcut Menu Item	Icon	Description
New		Create a new external data source: data source, entity, table, view, data store, data feed, report, or flat file.
Close		Collapses or expands the list of External Data Objects.
Save Model		Saves any changes made.
<a href="#">Grid Editor...</a>		The Grid Editor is a spreadsheet-like display format that is an alternative to the Model View tree view. This is valuable for large objects or business-related objects, such as business rules. Grid Editors can be printed or exported as a report.
Import - From ER/Studio Data Architect		<a href="#">Create New External Data Objects</a> : Select this command to open a wizard where you can select data files to import from ER/Studio Data Architect. <a href="#">Update Existing External Data Objects</a> : You can use this option to update an existing data source. All existing objects that match an object you have selected will be updated.
<a href="#">Export to ER/Studio Data Architect...</a>		You can export objects to ER/Studio Data Architect where the elements in the conceptual diagram map to the logical diagram in ER/Studio Data Architect.
Insert Data Source...		If you have deleted a data source file but did not <a href="#">delete the associated files</a> , you can select this command to "restore" the deleted data source file.
Refresh		Updates the currently displayed information with new data or changes.
<a href="#">Properties</a>		Opens the Property View dialog for the selected external data object.

## External Data Object elements

Once you have created an External Data Object element, a different shortcut menu is available:

Shortcut Menu Item	Icon	Description
New		Create a new external data source: data source, entity, table, view, data store, data feed, report, or flat file.
<a href="#">Create Diagram from Selected Elements...</a>		You can create new diagrams from existing model objects.
Rename		Makes the node name editable. If the diagram is open, it also renames the element in the Diagram View. You can also click F2.
Delete		This command opens the Delete Elements dialog asking if you are sure you want to delete the selected elements. Clicking Yes removes the elements from the project and any diagrams (both in the Model View tree and in the Diagram View) on which the elements appear.
Diagram Usage		A pull-right menu lists the diagram(s) the select element appears in. This allows you to quickly locate and open the diagram where the element appears. If the element appears on more than ten diagrams the More... option appears opening a dialog listing all diagrams.
Links		If you are creating a new link, click Links > New and the <a href="#">Create Link</a> wizard opens. If you are editing an existing link, click Links>Edit. If there are multiple links, the pull-right menu displays a list of the existing links. Click the name on the pull-right and the <a href="#">Edit Link</a> wizard opens. If there is only one link the command is Links > Edit.
Usage (CRUD)		If you are creating a new usage, click Usage > New and the <a href="#">Usages</a> wizard opens. If you want to edit or view an existing usage, click Usage (CRUD) > Edit or View. The Usage (CRUD) tab opens in the Property View for the selected element.
Impact Analysis		You have two commands available from the pull-right menu: You can generate an <a href="#">Impact Analysis Diagram</a> which graphically displays all the associated relationships and elements. You can also show the <a href="#">Impact Analysis Report</a> .
Refresh		Updates the currently displayed information with new data or changes.
<a href="#">Properties</a>		Opens the Property View dialog for the selected element.



## Palette view

The table below describes the functions available when you right-click the Palette View:

Shortcut Menu Item	Description
Layout	Columns: Displays the icons and object labels in two columns within the palette. List: Displays both the icon and the object label for each object in the palette. Icons Only: Displays the icons without identifying labels. Details: Displays each icon with a brief description of the action taken when you select the object.
Settings	Opens the <a href="#">Using the Palette</a> dialog where you can change the display characteristics of the palette.

## Diagram view

The table below describes the functions available when you right-click in the Diagram View:

Shortcut Menu Item	Icon	Description
Case Shift		You can set the default case shift for all element labels. You have three options:  Lower: All text appears in lower case lettering, including the initial letter of the label.  Preserve: Text appears as entered.  Upper: All text appears in upper case lettering.
Grid		This pull-right menu contains three additional commands:  Show Grid Lines: The grid lines appear on the diagram.  Show Parent Objects as Transparent: When a parent object such as a pool or lane is placed on a diagram, the grid lines appear in the object, i.e. the object is transparent.  Snap Objects to Grid: When an element is placed in the Diagram View, it automatically snaps to the nearest grid. When an element is moved, it also snaps to the nearest grid line.
Connections		If it is a Business Process diagram, this command shows or hides: All, Associations, Line Shapes, Links, Message Flows, Sequence Flows, or Usages.  If it is a Conceptual Model diagram, this command shows or hides: All, Interactions, Line Shapes, Links, Relationships, or Usages.  If it is a Impact Analysis diagram, this command shows or hides Links and Usages.
Edit		This opens a pull-right menu allowing you to select all elements in the diagram.
Layout		You have three choices: curved, elbowed, or straight. The default setting for connections is curved. If you change this setting to "straight" you get a Change Diagram Layout dialog, warning you that this selection overrides any changes you have made to individual relationships.
Connection Labels		The default setting is to show connection labels when drawn. You can select to hide or show all connection labels in the diagram.
<a href="#">Grid Editor...</a>		The Grid Editor is an spreadsheet-like display format that is an alternative to the Model View tree view. This is valuable for large objects or business-related objects, such as business rules. The Grid Editor can be printed or exported as a report.
Zoom In		Select this command to increase the size of the diagram in the view.
Zoom Out		Select this command to decrease the size of the diagram in the view.

## Elements

Shortcut menus are available for all the elements used in ER/Studio BA. All commands and a description of each are listed for each element. There are five different element sets:

- Business Process Modeling Objects
- Conceptual Objects
- Reference Objects
- External Data Objects
- Drawing Shapes

### Business Process Modeling Objects

The commands on the shortcut menus for the Business Process Modeling Objects are very similar. However additional commands appear on each of the objects. Shortcut menus are available for the following objects:





- Start and Intermediate Events
- End Events
- Tasks
- Embedded Sub-processes
- Independent Sub-processes
- Gateways
- Pools
- Lanes
- Sequence Flows
- Message Flows
- Associations
- Data Objects, Groups, Annotations, and Off-Page Connectors

### Start and Intermediate Events

A Start Event indicates where a particular process starts. A trigger for a Start Event is designed to show the general mechanism that instantiates that particular process. An Intermediate Event occurs between a Start Event and an End Event. It is an event that occurs after a Process has been started.

Shortcut Menu Item	Icon	Description
Show Name		This is a toggle command. If it is selected the element label shows.
Trigger Type		You can change the trigger on an event from the shortcut menu. When you select Trigger Type, a pull-right menu displays all the applicable triggers for the event, including the setting of "None".
Appearance...		Opens the Appearance tab in the Property View where you can edit the font and color options, horizontal alignments, and Diagram display options of the object.
Connections		This command shows or hides the following connection objects: All, Associations, Line Shapes, Links, Message Flows, Sequence Flows, or Usages.







Shortcut Menu Item	Icon	Description
<a href="#">Grouping</a>		Group: Groups two or more selected elements into a single entity that can be moved around a diagram in a block. Ungroup: Removes the selected grouping. This command is available only if the element selected is in a group.
Align Objects		When two or more objects are selected, the <a href="#">alignment</a> commands are available on a pull-right menu.
Order		This is a pull-right menu displaying two commands that control stacking of elements in the Diagram View: Bring to Front and Send to Back.
Edit		This opens a pull-right menu allowing you to cut, copy, paste, delete, or select all elements in the diagram.
Links		If you are creating a new link, click Links>New and the <a href="#">Create Link</a> wizard opens. If you are editing an existing link, click Links>Edit. If there are multiple links, the pull-right menu displays a list of the existing links. Click the name on the pull-right and the <a href="#">Edit Link</a> wizard opens. If there is only one link the command is Links>Edit. You can also select to show or hide the link in the Diagram View.
Usage (CRUD)		If you are creating a new usage, click Usage>New and the <a href="#">Usages</a> wizard opens. If you want to edit or view an existing usage, click Usage (CRUD)>Edit or View. The Usage (CRUD) tab opens in the Property View for the selected element. You can also select to show or hide the Usage in the Diagram View.
Impact Analysis		You have two commands available from the pull-right menu: You can generate an <a href="#">Impact Analysis Diagram</a> which graphically displays all the associated relationships and elements. You can also show the <a href="#">Impact Analysis Report</a> .
Find in Model View		Select this command to locate the selected element in the Model View tree.
<a href="#">Properties</a>		Opens the Property View dialog for the selected element.

## End Events

The End Event indicates where a process ends. You can define the consequences or results of reaching an End Event.





Shortcut Menu Item	Icon	Description
Show Name		This is a toggle command. If it is selected the element label shows.
Result Type		You can change the result type on an event from the shortcut menu. When you select Trigger Type, a pull-right menu displays the following results for the event: None, Cancel, Compensation, Error, Link, Message, and Terminate.
Appearance...		Opens the Appearance tab in the Property View where you can edit the font and color options, horizontal alignments, and Diagram display options of the object.
Connections		This command shows or hides the following connection objects: All, Associations, Line Shapes, Links, Message Flows, Sequence Flows, or Usages.

Shortcut Menu Item	Icon	Description
<a href="#">Grouping</a>		Group: Groups two or more selected elements into a single entity that can be moved around a diagram in a block. Ungroup: Removes the selected grouping. This command is available only if the element selected is in a group.
Align Objects		When two or more objects are selected, the <a href="#">alignment</a> commands are available on a pull-right menu.
Order		This is a pull-right menu displaying two commands that control stacking of elements in the Diagram View: Bring to Front and Send to Back.
Edit		This opens a pull-right menu allowing you to cut, copy, paste, delete, or select all elements in the diagram.
Links		If you are creating a new link, click Links>New and the <a href="#">Create Link</a> wizard opens. If you are editing an existing link, click Links>Edit. If there are multiple links, the pull-right menu displays a list of the existing links. Click the name on the pull-right and the <a href="#">Edit Link</a> wizard opens. If there is only one link the command is Links>Edit. You can also select to show or hide the link in the Diagram View.
Usage (CRUD)		If you are creating a new usage, click Usage>New and the <a href="#">Usages</a> wizard opens. If you want to edit or view an existing usage, click Usage (CRUD)>Edit or View. The Usage (CRUD) tab opens in the Property View for the selected element. You can also select to show or hide the Usage in the Diagram View.
Impact Analysis		You have two commands available from the pull-right menu: You can generate an <a href="#">Impact Analysis Diagram</a> which graphically displays all the associated relationships and elements. You can also show the <a href="#">Impact Analysis Report</a> .
Find in Model View		Select this command to locate the selected element in the Model View tree.
<a href="#">Properties</a>		Opens the Property View dialog for the selected element.

## Tasks

A task is an activity that is included within a Process. You use a Task when the work in the Process is not broken down to a finer level of Process Model detail.







Shortcut Menu Item	Icon	Description
Show Name		This is a toggle command. If it is selected the element label shows.
Appearance...		Opens the Appearance tab in the Property View where you can edit the font and color options, horizontal and vertical alignments, Diagram display options, and Line display options of the object.
Connections		This command shows or hides the following connection objects: All, Associations, Line Shapes, Links, Message Flows, Sequence Flows, or Usages.
<a href="#">Grouping</a>		Group: Groups two or more selected elements into a single entity that can be moved around a diagram in a block. Ungroup: Removes the selected grouping. This command is available only if the element selected is in a group.
Align Objects		When two or more objects are selected, the <a href="#">alignment</a> commands are available on a pull-right menu.

Shortcut Menu Item	Icon	Description
Order		This is a pull-right menu displaying two commands that control stacking of elements in the Diagram View: Bring to Front and Send to Back.
Edit		This opens a pull-right menu allowing you to cut, copy, paste, delete, or select all elements in the diagram.
<a href="#">Convert To</a>		You can convert a task to either an Embedded Sub-process or an Independent Sub-process
Links		If you are creating a new link, click Links>New and the <a href="#">Create Link</a> wizard opens. If you are editing an existing link, click Links>Edit. If there are multiple links, the pull-right menu displays a list of the existing links. Click the name on the pull-right and the <a href="#">Edit Link</a> wizard opens. If there is only one link the command is Links>Edit. You can also select to show or hide the link in the Diagram View.
Usage (CRUD)		If you are creating a new usage, click Usage>New and the <a href="#">Usages</a> wizard opens. If you want to edit or view an existing usage, click Usage (CRUD)>Edit or View. The Usage (CRUD) tab opens in the Property View for the selected element. You can also select to show or hide the Usage in the Diagram View.
Impact Analysis		You have two commands available from the pull-right menu: You can generate an <a href="#">Impact Analysis Diagram</a> which graphically displays all the associated relationships and elements. You can also show the <a href="#">Impact Analysis Report</a> .
Find in Model View		Select this command to locate the selected element in the Model View tree.
<a href="#">Properties</a>		Opens the Property View dialog for the selected element. When you right-click on a task and select Properties, three additional commands are available on the pull-right menu: Loop Type: Lists all available loop types in the pull-right menu. Select a type from the list to change it. Task Type: Lists all available task types in the pull-right menu. Select a type from the list to change it.

### Embedded Sub-processes



An Embedded (or nested) Sub-process element is an activity containing other activities (a Process). The Process within the Process depends on the parent Process for instigation and has visibility to the parent's global data.



Shortcut Menu Item	Icon	Description
Show Name		This is a toggle command. If it is selected the element label shows.
Show As Expanded		When you place an embedded sub-process in the Diagram View, the default setting displays it as an expanded sub-process. Select this toggle command to expand or contract the sub-process.
Appearance...		Opens the Appearance tab in the Property View where you can edit the font and color options, horizontal and vertical alignments, Diagram display options, and Line display options of the object.
Connections		This command shows or hides the following connection objects: All, Associations, Line Shapes, Links, Message Flows, Sequence Flows, or Usages.

Shortcut Menu Item	Icon	Description
<a href="#">Grouping</a>		Group: Groups two or more selected elements into a single entity that can be moved around a diagram in a block. Ungroup: Removes the selected grouping. This command is available only if the element selected is in a group.
Align Objects		When two or more objects are selected, the <a href="#">alignment</a> commands are available on a pull-right menu.
Order		This is a pull-right menu displaying two commands that control stacking of elements in the Diagram View: Bring to Front and Send to Back.
Edit		This opens a pull-right menu allowing you to cut, copy, paste, delete, or select all elements in the diagram.
<a href="#">Grid Editor...</a>		The Grid Editor is an spreadsheet-like display format that is an alternative to the Model View tree view. This is valuable for large objects or business-related objects, such as business rules. The Grid Editor can be printed or exported as a report.
Links		If you are creating a new link, click Links>New and the <a href="#">Create Link</a> wizard opens. If you are editing an existing link, click Links>Edit. If there are multiple links, the pull-right menu displays a list of the existing links. Click the name on the pull-right and the <a href="#">Edit Link</a> wizard opens. If there is only one link the command is Links>Edit. You can also select to show or hide the link in the Diagram View.
Usage (CRUD)		If you are creating a new usage, click Usage>New and the <a href="#">Usages</a> wizard opens. If you want to edit or view an existing usage, click Usage (CRUD)>Edit or View. The Usage (CRUD) tab opens in the Property View for the selected element. You can also select to show or hide the Usage in the Diagram View.
Impact Analysis		You have two commands available from the pull-right menu: You can generate an <a href="#">Impact Analysis Diagram</a> which graphically displays all the associated relationships and elements. You can also show the <a href="#">Impact Analysis Report</a> .
Find in Model View		Select this command to locate the selected element in the Model View tree.
Properties		
Loop Type		Lists all available loop types in the pull-right menu. Select a type from the list to change it.
Ad hoc		Ad hoc is a boolean attribute, which has a default of False. This specifies whether the Process is Ad Hoc or not. The activities within an Ad Hoc Process are not controlled or sequenced in a particular order. Their performance is determined by the performers of the activities. If set to True, then the Ad Hoc marker is placed at the bottom center of the Process or the Sub-Process shape for Ad Hoc Processes.
Transaction		This option determines whether or not the behavior of the Sub-Process will follow the behavior of a Transaction.
Display Properties		Opens the Properties dialog for the selected element.

## Independent Sub-processes



An Independent Sub-process element is an activity within a Process that “calls” to another Process that exists within a separate diagram. The Process that is called is not dependent on the Independent Sub-process’ parent Process for instantiation or global data.



Shortcut Menu Item	Icon	Description
Show Name		This is a toggle command. If it is selected the element label shows.
Show As Expanded		When you place an independent sub-process in the Diagram View, the default setting is that it is displayed as a contracted sub- process. Select this toggle command to open a diagram.
Appearance...		Opens the Appearance tab in the Property View where you can edit the font and color options, horizontal and vertical alignments, Diagram display options, and Line display options of the object.
Connections		This command shows or hides the following connection objects: All, Associations, Line Shapes, Links, Message Flows, Sequence Flows or Usages.
<a href="#">Grouping</a>		Group: Groups two or more selected elements into a single entity that can be moved around a diagram in a block. Ungroup: Removes the selected grouping. This command is available only if the element selected is in a group.
Align Objects		When two or more objects are selected, the <a href="#">alignment</a> commands are available on a pull-right menu.
Order		This is a pull-right menu displaying two commands that control stacking of elements in the Diagram View: Bring to Front and Send to Back.
Edit		This opens a pull-right menu allowing you to cut, copy, paste, delete, or select all elements in the diagram.
Links		If you are creating a new link, click Links>New and the <a href="#">Create Link</a> wizard opens. If you are editing an existing link, click Links>Edit. If there are multiple links, the pull-right menu displays a list of the existing links. Click the name on the pull-right and the <a href="#">Edit Link</a> wizard opens. If there is only one link the command is Links>Edit. You can also select to show or hide the link in the Diagram View.
Usage (CRUD)		If you are creating a new usage, click Usage>New and the <a href="#">Usages</a> wizard opens. If you want to edit or view an existing usage, click Usage (CRUD)>Edit or View. The Usage (CRUD) tab opens in the Property View for the selected element. You can also select to show or hide the Usage in the Diagram View.
Impact Analysis		You have two commands available from the pull-right menu: You can generate an <a href="#">Impact Analysis Diagram</a> which graphically displays all the associated relationships and elements. You can also show the <a href="#">Impact Analysis Report</a> .
Find in Model View		Select this command to locate the selected element in the Model View tree.

Shortcut Menu Item	Icon	Description
Properties		
Loop Type		Lists all available loop types in the pull-right menu. Select a type from the list to change it.
Transaction		This option determines whether or not the behavior of the Sub-Process follows the behavior of a Transaction.
Display Properties		Opens the Properties dialog for the selected element.

## Gateways

A Gateway controls the divergence and convergence of the Sequence Flow. It determines branching, forking, merging, and joining of paths.





Shortcut Menu Item	Icon	Description
Show Name		This is a toggle command. If it is selected the element label shows.
Gateway Type		Lists all available gateway types in the pull-right menu. Select a type from the list to change it.
Appearance		Opens the Appearance tab in the Property View where you can edit the font and color options, horizontal alignments, Diagram display options, and Line display options of the object.
Connections		This command shows or hides the following connection objects: All, Associations, Line Shapes, Links, Message Flows, Sequence Flows, or Usages.
<a href="#">Grouping</a>		Group: Groups two or more selected elements into a single entity that can be moved around a diagram in a block. Ungroup: Removes the selected grouping. This command is available only if the element selected is in a group.
Align Objects		When two or more objects are selected, the <a href="#">alignment</a> commands are available on a pull-right menu.
Order		This is a pull-right menu displaying two commands that control stacking of elements in the Diagram View: Bring to Front and Send to Back.
Edit		This opens a pull-right menu allowing you to cut, copy, paste, delete, or select all elements in the diagram.
Links		If you are creating a new link, click Links>New and the <a href="#">Create Link</a> wizard opens. If you are editing an existing link, click Links>Edit. If there are multiple links, the pull-right menu displays a list of the existing links. Click the name on the pull-right and the <a href="#">Edit Link</a> wizard opens. If there is only one link the command is Links>Edit. You can also select to show or hide the link in the Diagram View.
Usage (CRUD)		If you are creating a new usage, click Usage>New and the <a href="#">Usages</a> wizard opens. If you want to edit or view an existing usage, click Usage (CRUD)>Edit or View. The Usage (CRUD) tab opens in the Property View for the selected element. You can also select to show or hide the Usage in the Diagram View.

Shortcut Menu Item	Icon	Description
Impact Analysis		You have two commands available from the pull-right menu: You can generate an <a href="#">Impact Analysis Diagram</a> which graphically displays all the associated relationships and elements. You can also show the <a href="#">Impact Analysis Report</a> .
Find in Model View		Select this command to locate the selected element in the Model View tree.
<a href="#">Properties</a>		Opens the Property View dialog for the selected element.

## Pools

A Pool represents a participant in a [Process](#). It is also called a “swimlane” and is a graphical container for partitioning a set of activities from other pools.

Shortcut Menu Item	Icon	Description
Show Name		This is a toggle command. If it is selected the element label shows.
Appearance...		Opens the Appearance tab in the Property View where you can edit the font and color options, horizontal alignments, Diagram display options, and Line display options of the object.
Connections		This command shows or hides the following connection objects: All, Associations, Line Shapes, Links, Message Flows, Sequence Flows, or Usages.
<a href="#">Grouping</a>		Group: Groups two or more selected elements into a single entity that can be moved around a diagram in a block. Ungroup: Removes the selected grouping. This command is available only if the element selected is in a group.
Align Objects		When two or more objects are selected, the <a href="#">alignment</a> commands are available on a pull-right menu.
Order		This is a pull-right menu displaying two commands that control stacking of elements in the Diagram View: Bring to Front and Send to Back.
Edit		This opens a pull-right menu allowing you to cut, copy, paste, delete, or select all elements in the diagram.
Insert Lane		Inserts a lane in the pool. You can select where you want the lane placed in the pool from the pull-right menu.
Remove All Lanes (Black Box)		When all lanes are removed from a pool it becomes a black box pool. The pool header label remains, but the lane area is blank.
Show All Lanes		This is a toggle of the Remove All Lanes command. All hidden lanes in the pool are shown.
Links		If you are creating a new link, click Links>New and the <a href="#">Create Link</a> wizard opens. If you are editing an existing link, click Links>Edit. If there are multiple links, the pull-right menu displays a list of the existing links. Click the name on the pull-right and the <a href="#">Edit Link</a> wizard opens. If there is only one link the command is Links>Edit. You can also select to show or hide the link in the Diagram View.





Shortcut Menu Item	Icon	Description
Usage (CRUD)		If you are creating a new usage, click Usage>New and the <a href="#">Usages</a> wizard opens. If you want to edit or view an existing usage, click Usage (CRUD)>Edit or View. The Usage (CRUD) tab opens in the Property View for the selected element. You can also select to show or hide the Usage in the Diagram View.
<a href="#">Create Diagram from Selected Elements...</a>		This function gives you the ability to create a diagram from the Pool that exists on the diagram.
<a href="#">Grid Editor...</a>		The Grid Editor is an spreadsheet-like display format that is an alternative to the Model View tree view. This is valuable for large objects or business-related objects, such as business rules. The Grid Editor can be printed or exported as a report.
Impact Analysis		You have two commands available from the pull-right menu: You can generate an <a href="#">Impact Analysis Diagram</a> which graphically displays all the associated relationships and elements. You can also show the <a href="#">Impact Analysis Report</a> .
Find in Model View		Select this command to locate the selected element in the Model View tree.
<a href="#">Properties</a>		Opens the Property View dialog for the selected element.

## Lanes

A Lane is a subpartition within a pool. Lanes organize and categorize activities. Lanes are often used to separate the activities associated with a specific company function or role.

Shortcut Menu Item	Icon	Description
Show Name		This is a toggle command. If it is selected the element label shows.
Appearance...		Opens the Appearance tab in the Property View where you can edit the font and color options, horizontal alignments, and Diagram display options of the object.
Connections		This command shows or hides the following connection objects: All, Associations, Line Shapes, Links, Message Flows, Sequence Flows, or Usages.
Edit		This opens a pull-right menu allowing you to cut, copy, paste, delete, or select all elements in the diagram.
Insert Lane		Inserts a lane in the pool.
Move Lane		Opens the Move Lane dialog where you can reorder the lanes.
Remove All Lanes (Black Box)		When all lanes are removed from a pool it becomes a black box pool. The pool header label remains, but the lane area is blank.
Show All Lanes		This is a toggle of the Remove All Lanes command. All hidden lanes in the pool are shown.
<a href="#">Grid Editor...</a>		The Grid Editor is a spreadsheet-like display format that is an alternative to the Model View tree view. This is valuable for large objects or business-related objects, such as business rules. The Grid Editor can be printed or exported as a report.







Shortcut Menu Item	Icon	Description
Links		If you are creating a new link, click Links>New and the <a href="#">Create Link</a> wizard opens. If you are editing an existing link, click Links>Edit. If there are multiple links, the pull-right menu displays a list of the existing links. Click the name on the pull-right and the <a href="#">Edit Link</a> wizard opens. If there is only one link the command is Links>Edit. You can also select to show or hide the link in the Diagram View.
Usage (CRUD)		If you are creating a new usage, click Usage>New and the <a href="#">Usages</a> wizard opens. If you want to edit or view an existing usage, click Usage (CRUD)>Edit or View. The Usage (CRUD) tab opens in the Property View for the selected element. You can also select to show or hide the Usage in the Diagram View.
Impact Analysis		You have two commands available from the pull-right menu: You can generate an <a href="#">Impact Analysis Diagram</a> which graphically displays all the associated relationships and elements. You can also show the <a href="#">Impact Analysis Report</a> .
Find in Model View		Select this command to locate the selected element in the Model View tree.
<a href="#">Properties</a>		Opens the Property View dialog for the selected element.

## Sequence Flows





A Sequence Flow shows the sequence of processes in an organization or department. When you use pools or lanes in your diagram, you use Sequence Flow lines to connect events, activities, and gateways within the pools or lanes.

Shortcut Menu Item	Icon	Description
Show Name		This is a toggle command. If it is selected the element label is shown.
Condition Type		None  Conditional  Default
Appearance...		Opens the Appearance tab in the Property View where you can edit the font and color options, Diagram display options, and Line display options of the object.
Connections		This command shows or hides the following connection objects: All, Associations, Line Shapes, Links, Message Flows, Sequence Flows, or Usages.
Edit		This opens a pull-right menu allowing you to delete, or select all elements in the diagram.

Shortcut Menu Item	Icon	Description
Layout		<p>You can change the layout on individual connections. The commands available on the pull-right menu are:</p> <p>Curved: orthogonal bend points with “curved” corners are placed on the line.</p> <p>Elbowed: orthogonal bend points are placed on the line.</p> <p><u>Straight</u>: the line is always straight. However there can be bend points on the connection.</p> <p>Remove Bend Points: Removes all bends so the line traverses the shortest distance between two elements.</p> <p>Reset to Default Docking Position: The docking position of the line/element intersection is reset to its default setting.</p>
Links		<p>If you are creating a new link, click Links&gt;New and the <a href="#">Create Link</a> wizard opens. If you are editing an existing link, click Links&gt;Edit. If there are multiple links, the pull-right menu displays a list of the existing links. Click the name on the pull-right and the <a href="#">Edit Link</a> wizard opens. If there is only one link the command is Links&gt;Edit. You can also select to show or hide the link in the Diagram View.</p>
Usage (CRUD)		<p>If you are creating a new usage, click Usage&gt;New and the <a href="#">Usages</a> wizard opens. If you want to edit or view an existing usage, click Usage (CRUD)&gt;Edit or View. The Usage (CRUD) tab opens in the Property View for the selected element. You can also select to show or hide the Usage in the Diagram View.</p>
Impact Analysis		<p>You have two commands available from the pull-right menu:</p> <p>You can generate an <a href="#">Impact Analysis Diagram</a> which graphically displays all the associated relationships and elements.</p> <p>You can also show the <a href="#">Impact Analysis Report</a>.</p>
Find in Model View		Select this command to locate the selected element in the Model View tree.
<a href="#">Properties</a>		Opens the Property View dialog for the selected element.





## Message Flows



Message Flows are used to show the flow of messages between two participants that are prepared to send and receive them. A Message Flow can connect directly to the boundary of a pool or it can cross the boundary of a pool and connect to an object within that pool.

Shortcut Menu Item	Icon	Description
Show Name		This is a toggle command. If it is selected the element label is shown.
Appearance...		Opens the Appearance tab in the Property View where you can edit the font and color options, Diagram display options, and Line display options of the object.
Connections		This command shows or hides the following connection objects: All, Associations, Line Shapes, Links, Message Flows, Sequence Flows or Usages.
Edit		This opens a pull-right menu allowing you to delete, or select all elements in the diagram.
Layout		You can change the layout on individual connections. The commands e available on the pull-right menu are: Curved: orthogonal bend points with "curved" corners are placed on the line. Elbowed: orthogonal bend points are placed on the line. Straight: the line is always straight. However there can be bend points on the connection. Remove Bend Points: Removes all bends so the line traverses the shortest distance between two elements. Reset to Default Docking Position: The docking position of the line/element intersection is reset to its default setting.
Links		If you are creating a new link, click Links>New and the <a href="#">Create Link</a> wizard opens. If you are editing an existing link, click Links>Edit. If there are multiple links, the pull-right menu displays a list of the existing links. Click the name on the pull-right and the <a href="#">Edit Link</a> wizard opens. If there is only one link the command is Links>Edit. You can also select to show or hide the link in the Diagram View.
Usage (CRUD)		If you are creating a new usage, click Usage>New and the <a href="#">Usages</a> wizard opens. If you want to edit or view an existing usage, click Usage (CRUD)>Edit or View. The Usage (CRUD) tab opens in the Property View for the selected element. You can also select to show or hide the Usage in the Diagram View.
Impact Analysis		You have two commands available from the pull-right menu: You can generate an <a href="#">Impact Analysis Diagram</a> which graphically displays all the associated relationships and elements. You can also show the <a href="#">Impact Analysis Report</a> .
Find in Model View		Select this command to locate the selected element in the Model View tree.
<a href="#">Properties</a>		Opens the Property View dialog for the selected element.

## Associations

An Association is used to associate information with events and activities. It can be used to associate reference objects, external data objects, shapes, and activities with textual information.





Shortcut Menu Item	Icon	Description
Show Name		This is a toggle command. If it is selected the element label is shown.
Directional Arrow		You can change the direction on an Association connecting object from the shortcut menu. When you select Direction Arrow, a pull-right menu displays the following options: None: (  ) No directional arrows are shown. To: (  ) Displays the arrow at the target element. From: (  ) Displays the arrow at the source element. Both: (  ) Directional arrows are shown at both ends of the connecting object.
Appearance...		Opens the Appearance tab in the Property View where you can edit the font and color options, Diagram display options, and Line display options of the object.
Connections		This command shows or hides the following connection objects: All, Associations, Line Shapes, Links, Message Flows, Sequence Flows, or Usages.
Edit		This opens a pull-right menu allowing you to cut, copy, paste, delete, or select all elements in the diagram.
Layout		You can change the layout on individual connections. The commands available on the pull-right menu are: Curved: orthogonal bend points with "curved" corners are placed on the line. Elbowed: orthogonal bend points are placed on the line. Straight: the line is always straight. However there can be bend points on the connection. Remove Bend Points: Removes all bends so the line traverses the shortest distance between two elements. Reset to Default Docking Position: The docking position of the line/element intersection is reset to its default setting.
Links		If you are creating a new link, click Links>New and the <a href="#">Create Link</a> wizard opens. If you are editing an existing link, click Links>Edit. If there are multiple links, the pull-right menu displays a list of the existing links. Click the name on the pull-right and the <a href="#">Edit Link</a> wizard opens. If there is only one link the command is Links>Edit. You can also select to show or hide the link in the Diagram View.

Shortcut Menu Item	Icon	Description
Usage (CRUD)		If you are creating a new usage, click Usage>New and the <a href="#">Usages</a> wizard opens. If you want to edit or view an existing usage, click Usage (CRUD)>Edit or View. The Usage (CRUD) tab opens in the Property View for the selected element. You can also select to show or hide the Usage in the Diagram View.
Impact Analysis		You have two commands available from the pull-right menu: You can generate an <a href="#">Impact Analysis Diagram</a> which graphically displays all the associated relationships and elements. You can also show the <a href="#">Impact Analysis Report</a> .
Find in Model View		Select this command to locate the selected element in the Model View tree.
<a href="#">Properties</a>		Opens the Property View dialog for the selected element.

### Data Objects, Groups, Annotations, and Off-Page Connectors

Artifacts provide additional information about the business process. Using artifacts allows you to add non-standard elements to satisfy a specific need. Since you do not want to alter the basic look-and-feel of a diagram, you can use artifacts to link to the existing events and activities through Associations. Artifacts do not affect the basic Sequence Flow or Message Flow, nor do they affect mapping to execution languages.

Shortcut Menu Item	Icon	Description
Show Name		This is a toggle command. If it is selected the element label shows. This command does not apply to the Annotation object.
Show State		This command applies to the Data Object element only.
Appearance...		Opens the Appearance tab in the Property View where you can edit the font and color options, horizontal alignment, and Diagram display options of the object.
Connections		This command shows or hides the following connection objects: All, Associations, Line Shapes, Links, Message Flows, Sequence Flows, or Usages.
<a href="#">Grouping</a>		Group: Groups two or more selected elements into a single entity that can be moved around a diagram in a block. Ungroup: Removes the selected grouping. This command is available only if the element selected is in a group.
Align Objects		When two or more objects are selected, the <a href="#">alignment</a> commands are available on a pull-right menu.
Order		This is a pull-right menu displaying two commands that control stacking of elements in the Diagram View: Bring to Front and Send to Back.
Edit		This opens a pull-right menu allowing you to cut, copy, paste, delete, or select all elements in the diagram.

Shortcut Menu Item	Icon	Description
Links		If you are creating a new link, click Links>New and the <a href="#">Create Link</a> wizard opens. If you are editing an existing link, click Links>Edit. If there are multiple links, the pull-right menu displays a list of the existing links. Click the name on the pull-right and the <a href="#">Edit Link</a> wizard opens. If there is only one link the command is Links>Edit. You can also select to show or hide the link in the Diagram View.
Usage (CRUD)		If you are creating a new usage, click Usage>New and the <a href="#">Usages</a> wizard opens. If you want to edit or view an existing usage, click Usage (CRUD)>Edit or View. The Usage (CRUD) tab opens in the Property View for the selected element. You can also select to show or hide the Usage in the Diagram View.
Impact Analysis		You have two commands available from the pull-right menu: You can generate an <a href="#">Impact Analysis Diagram</a> which graphically displays all the associated relationships and elements. You can also show the <a href="#">Impact Analysis Report</a> .
Find in Model View		Select this command to locate the selected element in the Model View tree.
<a href="#">Properties</a>		Opens the Property View dialog for the selected element.

## Conceptual objects





The commands on the shortcut menus for the Conceptual Modeling Objects are very similar. However additional commands appear on each of the objects. Shortcut menus are available for the following objects:

- [Subject Area](#)
- [Business Entity](#)
- [Business Attribute](#)
- [Interaction](#)
- [Relationship](#)

## Subject Area



Conceptual Modeling allows Business Users to create high-level designs of the core “concepts” and subject areas that drive the business, which can be passed onto data and process modelers to drive more detailed logical and physical design. A Subject Area can reference a collection of entities.

Shortcut Menu Item	Icon	Description
Show Name		This is a toggle command. If it is selected the element label shows.
Show As Expanded		Shows or hides the expand/contract control that appears in the right-hand corner of the object.
Show Expansion Control		You can hide or show the expander indicator located in the lower right-hand corner of the object. The expander is shown as the default setting.



Shortcut Menu Item	Icon	Description
Appearance...		Opens the Appearance tab in the Property View where you can edit the font and color options, horizontal and vertical alignment, Diagram display options, Line display options, and shape options of the object.
Connections		This command shows or hides the following connection objects: All, Relationships, Interactions, Line Shapes, Links, or Usages.
<a href="#">Grouping</a>		Group: Groups two or more selected elements into a single entity that can be moved around a diagram in a block. Ungroup: Removes the selected grouping. This command is available only if the element selected is in a group.
Align Objects		When two or more objects are selected, the <a href="#">alignment</a> commands are available on a pull-right menu.
Order		This is a pull-right menu displaying two commands that control stacking of elements in the Diagram View: Bring to Front and Send to Back.
Edit		This opens a pull-right menu allowing you to cut, copy, paste, delete, or select all elements in the diagram.
<a href="#">Create Mapping/Edit Mapping</a>		You can map a Subject Area to one or more Conceptual Model diagrams or Business Entities.
Diagram Mapping		This command is available once you have mapped a diagram to a Subject Area. When it is selected a pull-right menu opens displaying the mapped diagram(s).
Links		If you are creating a new link, click Links>New and the <a href="#">Create Link</a> wizard opens. If you are editing an existing link, click Links>Edit. If there are multiple links, the pull-right menu displays a list of the existing links. Click the name on the pull-right and the <a href="#">Edit Link</a> wizard opens. If there is only one link the command is Links>Edit. You can also select to show or hide the link in the Diagram View.
Usage (CRUD)		If you are creating a new usage, click Usage>New and the <a href="#">Usages</a> wizard opens. If you want to edit or view an existing usage, click Usage (CRUD)>Edit or View. The Usage (CRUD) tab opens in the Property View for the selected element. You can also select to show or hide the Usage in the Diagram View.
<a href="#">Create Diagram from Selected Elements...</a>		This function gives you the ability to create a diagram from the Subject Area element that exists on the diagram.
<a href="#">Grid Editor...</a>		The Grid Editor is an spreadsheet-like display format that is an alternative to the Model View tree view. This is valuable for large objects or business-related objects, such as business rules. The Grid Editor can be printed or exported as a report.
Impact Analysis		You have two commands available from the pull-right menu: You can generate an <a href="#">Impact Analysis Diagram</a> which graphically displays all the associated relationships and elements. You can also show the <a href="#">Impact Analysis Report</a> .
Find in Model View		Select this command to locate the selected element in the Model View tree.
<a href="#">Properties</a>		Opens the Property View dialog for the selected element.

## Business Entity

A Business Entity is a high-level “container” for businesses/organizations. They can stand alone or can be containers for other Business Entities or Business Attributes.



Shortcut Menu Item	Icon	Description
Show Name		This is a toggle command. If it is selected the element label shows.
Show As Expanded		Shows or hides the expand/contract control that appears in the right-hand corner of the object.
Show Expansion Control		You can hide or show the expander indicator located in the lower right-hand corner of the object. The expander is shown as the default setting.
Appearance...		Opens the Appearance tab in the Property View where you can edit the font and color options, horizontal and vertical alignment, Diagram display options, Line display options, and Business Attribute display options of the object.
Connections		This command shows or hides the following connection objects: All, Relationships, Interactions, Line Shapes, Links, or Usages.
<a href="#">Grouping</a>		Group: Groups two or more selected elements into a single entity that can be moved around a diagram in a block. Ungroup: Removes the selected grouping. This command is available only if the element selected is in a group.
Align Objects		When two or more objects are selected, the <a href="#">alignment</a> commands are available on a pull-right menu.
Order		This is a pull-right menu displaying two commands that control stacking of elements in the Diagram View: Bring to Front and Send to Back.
Edit		This opens a pull-right menu allowing you to cut, copy, paste, delete, or select all elements in the diagram.
Insert Attribute		Inserts a Business Attribute in the Business Entity.
Links		If you are creating a new link, click Links>New and the <a href="#">Create Link</a> wizard opens. If you are editing an existing link, click Links>Edit. If there are multiple links, the pull-right menu displays a list of the existing links. Click the name on the pull-right and the <a href="#">Edit Link</a> wizard opens. If there is only one link the command is Links>Edit. You can also select to show or hide the link in the Diagram View.
Usage (CRUD)		If you are creating a new usage, click Usage>New and the <a href="#">Usages</a> wizard opens. If you want to edit or view an existing usage, click Usage (CRUD)>Edit or View. The Usage (CRUD) tab opens in the Property View for the selected element. You can also select to show or hide the Usage in the Diagram View.
<a href="#">Create Diagram from Selected Elements...</a>		This function gives you the ability to create a diagram from the Business Entity element that exists on the diagram.
<a href="#">Grid Editor...</a>		The Grid Editor is a spreadsheet-like display format that is an alternative to the Model View tree view. This is valuable for large objects or business-related objects, such as business rules. The Grid Editor can be printed or exported as a report.





Shortcut Menu Item	Icon	Description
Impact Analysis		You have two commands available from the pull-right menu: You can generate an <a href="#">Impact Analysis Diagram</a> which graphically displays all the associated relationships and elements. You can also show the <a href="#">Impact Analysis Report</a> .
Find in Model View		Select this command to locate the selected element in the Model View tree.
<a href="#">Properties</a>		Opens the Property View dialog for the selected element.

## Business Attribute

Business Attributes are the low-level details (i.e., properties), of a Business Entity. You can reorder the Business Attributes within a Business Entity.



Shortcut Menu Item	Icon	Description
Unique Identifier		This is a toggle that turns the Unique Identifier setting (#) on or off for the selected attribute.
Data Type		The Data Types available are high level: binary, BLOB/Image, boolean, char, CLOB/Large Text, Decimal, Date, Integer, Time Stamp, Varchar, and XML. The data type selected appears in the Property View for the selected attribute.
Optionality		You can set the Optionality for an attribute. If you select Mandatory it becomes a "required" property and a plus sign (+) appears to the left of the attribute. If it is optional, a minus sign (-) appears to the left of the attribute. You can set a <a href="#">preference</a> under the Display Options for Business Entities to always show the optionality indicator for Business Attributes.
Appearance...		Opens the Appearance tab in the Property View where you can edit the font and color options and horizontal alignment of the object.
Connections		This command shows or hides the following connection objects: All, Relationships, Interactions, Line Shapes, Links, or Usages.
<a href="#">Grouping</a>		Group: Groups two or more selected elements into a single entity that can be moved around a diagram in a block. Ungroup: Removes the selected grouping. This command is available only if the element selected is in a group.
Edit		This opens a pull-right menu allowing you to cut, copy, paste, delete, or select all elements in the diagram.
Links		If you are creating a new link, click Links>New and the <a href="#">Create Link</a> wizard opens. If you are editing an existing link, click Links>Edit. If there are multiple links, the pull-right menu displays a list of the existing links. Click the name on the pull-right and the <a href="#">Edit Link</a> wizard opens. If there is only one link the command is Links>Edit. You can also select to show or hide the link in the Diagram View.
Usage (CRUD)		If you are creating a new usage, click Usage>New and the <a href="#">Usages</a> wizard opens. If you want to edit or view an existing usage, click Usage (CRUD)>Edit or View. The Usage (CRUD) tab opens in the Property View for the selected element. You can also select to show or hide the Usage in the Diagram View.

Shortcut Menu Item	Icon	Description
Impact Analysis		You have two commands available from the pull-right menu: You can generate an <a href="#">Impact Analysis Diagram</a> which graphically displays all the associated relationships and elements. You can also show the <a href="#">Impact Analysis Report</a> .
Find in Model View		Select this command to locate the selected element in the Model View tree.
<a href="#">Properties</a>		Opens the Property View dialog for the selected element.

## Interaction

An interaction represents an action, process, or transaction between two objects. These interactions are often expressed as action verb phrases.





Shortcut Menu Item	Icon	Description
Show		You can show the name, verb phrase and inverse verb phrase for the Interaction.
Appearance...		Opens the Appearance tab in the Property View where you can edit the font and color options, Diagram display options, and Line display options of the object.
Connections		This command shows or hides the following connection objects: All, Relationships, Interactions, Line Shapes, Links, or Usages.
Edit		This opens a pull-right menu allowing you to delete, or select all elements in the diagram.
Layout		You can change the layout on individual connections. The commands available on the pull-right menu are: Curved: Orthogonal bend points with "curved" corners are placed on the line. Elbowed: Orthogonal bend points are placed on the line. Straight: The line is always straight. However there can be bend points on the connection. Remove Bend Points: Removes all bends so the line traverses the shortest distance between two elements. Reset to Default Docking Position: The docking position of the line/element intersection is reset to its default setting.
Links		If you are creating a new link, click Links>New and the <a href="#">Create Link</a> wizard opens. If you are editing an existing link, click Links>Edit. If there are multiple links, the pull-right menu displays a list of the existing links. Click the name on the pull-right and the <a href="#">Edit Link</a> wizard opens. If there is only one link the command is Links>Edit. You can also select to show or hide the link in the Diagram View.

Shortcut Menu Item	Icon	Description
Usage (CRUD)		If you are creating a new usage, click Usage>New and the <a href="#">Usages</a> wizard opens. If you want to edit or view an existing usage, click Usage (CRUD)>Edit or View. The Usage (CRUD) tab opens in the Property View for the selected element. You can also select to show or hide the Usage in the Diagram View.
Impact Analysis		You have two commands available from the pull-right menu: You can generate an <a href="#">Impact Analysis Diagram</a> which graphically displays all the associated relationships and elements. You can also show the <a href="#">Impact Analysis Report</a> .
Find in Model View		Select this command to locate the selected element in the Model View tree.
<a href="#">Properties</a>		Opens the Property View dialog for the selected element.

## Relationship

Relationships can only be defined between common object types. For example two business entities can have a relationship, but a business entity and a subject area cannot.

Shortcut Menu Item	Icon	Description
Show		You can show the name, verb phrase inverse verb phrase, and unique identifier for the Relationship.
Relationship Type		Sets the Relationship type. You can view and/or change this setting in the Property View. Your choices are: <ul style="list-style-type: none"> <li>• Generic</li> <li>• Many-to-Many</li> <li>• Many to One</li> <li>• One to Many</li> </ul>
Optionality		Sets the Source to Target Optionality. You can view and/or change this setting in the Property View. You choices are: <ul style="list-style-type: none"> <li>• Optional to Optional</li> <li>• Optionality to Mandatory</li> <li>• None</li> <li>• Mandatory to Optional</li> <li>• Mandatory to Mandatory</li> </ul>
Appearance...		Opens the Appearance tab in the Property View where you can edit the font and color options, Diagram display options, and Line display options of the object.
Connections		This command shows or hides the following connection objects: All, Relationships, Interactions, Line Shapes, Links or Usage.
Edit		This opens a pull-right menu allowing you to delete, or select all elements in the diagram.

Shortcut Menu Item	Icon	Description
Layout		<p>You can change the layout on individual connections. The commands available on the pull-right menu are:</p> <p>Curved: orthogonal bend points with "curved" corners are placed on the line.</p> <p>Elbowed: orthogonal bend points are placed on the line.</p> <p>Straight: the line is always straight. However there can be bend points on the connection.</p> <p>Remove Bend Points: Removes all bends so the line traverses the shortest distance between two elements.</p> <p>Reset to Default Docking Position: The docking position of the line/element intersection is reset to its default setting.</p>
Links		<p>If you are creating a new link, click Links&gt;New and the <a href="#">Create Link</a> wizard opens. If you are editing an existing link, click Links&gt;Edit. If there are multiple links, the pull-right menu displays a list of the existing links. Click the name on the pull-right and the <a href="#">Edit Link</a> wizard opens. If there is only one link the command is Links&gt;Edit.</p> <p>You can also select to show or hide the link in the Diagram View.</p>
Usage (CRUD)		<p>If you are creating a new usage, click Usage&gt;New and the <a href="#">Usages</a> wizard opens. If you want to edit or view an existing usage, click Usage (CRUD)&gt;Edit or View. The Usage (CRUD) tab opens in the Property View for the selected element.</p> <p>You can also select to show or hide the Usage in the Diagram View.</p>
Impact Analysis		<p>You have two commands available from the pull-right menu:</p> <p>You can generate an <a href="#">Impact Analysis Diagram</a> which graphically displays all the associated relationships and elements.</p> <p>You can also show the <a href="#">Impact Analysis Report</a>.</p>
<a href="#">Impact Analysis Report...</a>		<p>An Impact Analysis Report can be generated for any node on the Model View tree. It shows the interrelationships between objects. Impact Analysis reports can be printed or exported.</p>
Find in Model View		<p>Select this command to locate the selected element in the Model View tree.</p>
<a href="#">Properties</a>		<p>Opens the Property View dialog for the selected element.</p>

## Reference Objects

The commands on the shortcut menus for the Reference Objects in a diagram are very similar. However additional commands appear on each of the objects. Since Domains are not visible in a diagram, no shortcut menu is available here.



Shortcut menus are available for the following objects:

- [Business Element](#)
- [Business Rule](#)
- [Business Unit](#)
- [Steward](#)
- [Links](#)
- [Usage](#)



## Business Element



Business Elements are often used by business users to document their list of “terms and/or definitions”. While from a business user’s point-of-view, this may be no more than a list of terms, they can be used by a modeler to seed attributes of semantically-rich models.



Shortcut Menu Item	Icon	Description
Show Name		This is a toggle command. If it is selected the element label shows.
Appearance...		Opens the Appearance tab in the Property View where you can edit the font and color options, horizontal alignment, and Diagram display options of the object.
Connections		This command shows or hides the following connection objects: All, Interactions, Line Shapes, Links, Relationships, or Usages.
<a href="#">Grouping</a>		Group: Groups two or more selected elements into a single entity that can be moved around a diagram in a block. Ungroup: Removes the selected grouping. This command is available only if the element selected is in a group.
Align Objects		When two or more objects are selected, the <a href="#">alignment</a> commands are available on a pull-right menu.
Order		This is a pull-right menu displaying two commands that control stacking of elements in the Diagram View: Bring to Front and Send to Back.
Edit		This opens a pull-right menu allowing you to cut, copy, paste, delete, or select all elements in the diagram.
<a href="#">Binding Business Attributes to Business Elements...</a>		Opens the Bindings tab for the selected Business Element. You can add, edit or delete bindings.
Links		If you are creating a new link, click Links>New and the <a href="#">Create Link</a> wizard opens. If you are editing an existing link, click Links>Edit. If there are multiple links, the pull-right menu displays a list of the existing links. Click the name on the pull-right and the <a href="#">Edit Link</a> wizard opens. If there is only one link the command is Links>Edit. You can also select to show or hide the link in the Diagram View.
Usage (CRUD)		If you are creating a new usage, click Usage>New and the <a href="#">Usages</a> wizard opens. If you want to edit or view an existing usage, click Usage (CRUD)>Edit or View. The Usage (CRUD) tab opens in the Property View for the selected element. You can also select to show or hide the Usage in the Diagram View.
<a href="#">Create Diagram from Selected Elements...</a>		This function gives you the ability to create a diagram from the Business Element that exists on the diagram.
Impact Analysis		You have two commands available from the pull-right menu: You can generate an <a href="#">Impact Analysis Diagram</a> which graphically displays all the associated relationships and elements. You can also show the <a href="#">Impact Analysis Report</a> .

Shortcut Menu Item	Icon	Description
Find in Model View		Select this command to locate the selected element in the Model View tree.
<a href="#">Properties</a>		Opens the Property View dialog for the selected element.

## Business Rule

A business rule is a policy, practice, or formula related to the operation and enforcement of business practices.

Shortcut Menu Item	Icon	Description
Show Name		This is a toggle command. If it is selected the element label shows.
Appearance...		Opens the Appearance tab in the Property View where you can edit the font and color options, horizontal alignment, and Diagram display options of the object.
Connections		This command shows or hides the following connection objects: All, Interactions, Line Shapes, Links, Relationships, or Usages.
<a href="#">Grouping</a>		Group: Groups two or more selected elements into a single entity that can be moved around a diagram in a block. Ungroup: Removes the selected grouping. This command is available only if the element selected is in a group.
Align Objects		When two or more objects are selected, the <a href="#">alignment</a> commands are available on a pull-right menu.
Order		This is a pull-right menu displaying two commands that control stacking of elements in the Diagram View: Bring to Front and Send to Back.
Edit		This opens a pull-right menu allowing you to cut, copy, paste, delete, or select all elements in the diagram.
Links		If you are creating a new link, click Links>New and the <a href="#">Create Link</a> wizard opens. If you are editing an existing link, click Links>Edit. If there are multiple links, the pull-right menu displays a list of the existing links. Click the name on the pull-right and the <a href="#">Edit Link</a> wizard opens. If there is only one link the command is Links>Edit. You can also select to show or hide the link in the Diagram View.
Usage (CRUD)		If you are creating a new usage, click Usage>New and the <a href="#">Usages</a> wizard opens. If you want to edit or view an existing usage, click Usage (CRUD)>Edit or View. The Usage (CRUD) tab opens in the Property View for the selected element. You can also select to show or hide the Usage in the Diagram View.
<a href="#">Create Diagram from Selected Elements...</a>		This function gives you the ability to create a diagram from the Business Rule element that exists on the diagram.



Shortcut Menu Item	Icon	Description
Impact Analysis		You have two commands available from the pull-right menu: You can generate an <a href="#">Impact Analysis Diagram</a> which graphically displays all the associated relationships and elements. You can also show the <a href="#">Impact Analysis Report</a> .
Find in Model View		Select this command to locate the selected element in the Model View tree.
<a href="#">Properties</a>		Opens the Property View dialog for the selected element.

## Business Unit

A business unit is an organizational area within or external to an enterprise, for example, Human Resources, Sales, Accounting, etc.

Shortcut Menu Item	Icon	Description
Show Name		This is a toggle command. If it is selected the element label shows.
Appearance...		Opens the Appearance tab in the Property View where you can edit the font and color options, horizontal alignment, and Diagram display options of the object.
Connections		This command shows or hides the following connection objects: All, Line Shapes, Links or Usages.
<a href="#">Grouping</a>		Group: Groups two or more selected elements into a single entity that can be moved around a diagram in a block. Ungroup: Removes the selected grouping. This command is available only if the element selected is in a group.
Align Objects		When two or more objects are selected, the <a href="#">alignment</a> commands are available on a pull-right menu.
Order		This is a pull-right menu displaying two commands that control stacking of elements in the Diagram View: Bring to Front and Send to Back.
Edit		This opens a pull-right menu allowing you to cut, copy, paste, delete, or select all elements in the diagram.
<a href="#">Creating as Pool</a>		This creates a pool and lane with the same name as the Business Unit. The Business Unit is automatically associated with the Pool as a participant. A conceptual link from the Pool to the Business Unit is also created. The name of the link is the name of the Business Unit. This command is enabled only when Business Process diagrams are open.
<a href="#">Detaching from Pool</a>		Once you have created a Business Unit or Steward as a pool you can eliminate the relationship between the reference object and the pool. This command is enabled only when Business Process diagrams are open.
Links		If you are creating a new link, click Links>New and the <a href="#">Create Link</a> wizard opens. If you are editing an existing link, click Links>Edit. If there are multiple links, the pull-right menu displays a list of the existing links. Click the name on the pull-right and the <a href="#">Edit Link</a> wizard opens. If there is only one link the command is Links>Edit. You can also select to show or hide the link in the Diagram View.







Shortcut Menu Item	Icon	Description
Usage (CRUD)		If you are creating a new usage, click Usage>New and the <a href="#">Usages</a> wizard opens. If you want to edit or view an existing usage, click Usage (CRUD)>Edit or View. The Usage (CRUD) tab opens in the Property View for the selected element. You can also select to show or hide the Usage in the Diagram View.
<a href="#">Create Diagram from Selected Elements...</a>		This function gives you the ability to create a diagram from the Business Unit element that exists on the diagram.
Impact Analysis		You have two commands available from the pull-right menu: You can generate an <a href="#">Impact Analysis Diagram</a> which graphically displays all the associated relationships and elements. You can also show the <a href="#">Impact Analysis Report</a> .
Find in Model View		Select this command to locate the selected element in the Model View tree.
<a href="#">Properties</a>		Opens the Property View dialog for the selected element.

## Steward

A steward is a person or organization responsible for or associated with a model element, for example: DBA, Auditor, Jeffrey Smith, etc.

Shortcut Menu Item	Icon	Description
Show Name		This is a toggle command. If it is selected the element label shows.
Appearance...		Opens the Appearance tab in the Property View where you can edit the font and color options, horizontal alignment, and Diagram display options of the object.
Connections		This command shows or hides the following connection objects: All, Interactions, Line Shapes, Links, Relationships, or Usages.
<a href="#">Grouping</a>		Group: Groups two or more selected elements into a single entity that can be moved around a diagram in a block. Ungroup: Removes the selected grouping. This command is available only if the element selected is in a group.
Align Objects		When two or more objects are selected, the <a href="#">alignment</a> commands are available on a pull-right menu.
Order		This is a pull-right menu displaying two commands that control stacking of elements in the Diagram View: Bring to Front and Send to Back.
Edit		This opens a pull-right menu allowing you to cut, copy, paste, delete, or select all elements in the diagram.
<a href="#">Creating as Pool</a>		This creates a pool and lane with the same name as the Steward. The Steward is automatically associated with the Pool as a participant. A conceptual link from the Pool to the Steward is also created. The name of the link is the name of the Steward. This command is enabled only when Business Process diagrams are open.

Shortcut Menu Item	Icon	Description
<a href="#">Detaching from Pool</a>		Once you have created a Business Unit or Steward as a pool you can eliminate the relationship between the reference object and the pool. This command is enabled only when Business Process diagrams are open.
Links		If you are creating a new link, click Links>New and the <a href="#">Create Link</a> wizard opens. If you are editing an existing link, click Links>Edit. If there are multiple links, the pull-right menu displays a list of the existing links. Click the name on the pull-right and the <a href="#">Edit Link</a> wizard opens. If there is only one link the command is Links>Edit. You can also select to show or hide the link in the Diagram View.
Usage (CRUD)		If you are creating a new usage, click Usage>New and the <a href="#">Usages</a> wizard opens. If you want to edit or view an existing usage, click Usage (CRUD)>Edit or View. The Usage (CRUD) tab opens in the Property View for the selected element. You can also select to show or hide the Usage in the Diagram View.
Impact Analysis		You have two commands available from the pull-right menu: You can generate an <a href="#">Impact Analysis Diagram</a> which graphically displays all the associated relationships and elements. You can also show the <a href="#">Impact Analysis Report</a> .
Find in Model View		Select this command to locate the selected element in the Model View tree.
<a href="#">Properties</a>		Opens the Property View dialog for the selected element.

## Links

With a link you create a representation of a relationship between elements. These elements can consist of reference objects, data objects, and elements within a diagram.

Shortcut Menu Item	Description
Show	Name (Type) Verb Phrase Inverse Verb Phrase
Appearance...	Opens the Appearance tab in the Property View where you can edit the font and color options, Diagram display options, and Line display options of the object.
Connections	If you right-click on a connection (for example a Sequence Flow) you get the following commands: Hide Selected: The selected connection no longer appears in the diagram. Show Attached/Hide Attached: <ul style="list-style-type: none"> <li>• If it is a Business Process diagram, the command shows or hides the following: All, Associations, Line Shapes, Links, Message Flows, Sequence Flows, or Usages.</li> <li>• If it is a Conceptual Model diagram, the command shows or hides the following: All, Interactions, Line Shapes, Links, Relationships, or Usages.</li> </ul>
Edit	This opens a pull-right menu allowing you to cut, copy, paste, delete, or select all elements in the diagram.

Shortcut Menu Item	Description
Layout	<p>You can change the layout on individual connections. The commands available on the pull-right menu are:</p> <p>Curved: Orthogonal bend points with "curved" corners are placed on the line.</p> <p>Elbowed: Orthogonal bend points are placed on the line.</p> <p>Straight: The line is always straight. However there can be bend points on the connection.</p> <p>Remove Bend Points: Removes all bends so the line traverses the shortest distance between two elements.</p> <p>Reset to Default Docking Position: The docking position of the line/element intersection is reset to its default setting.</p>
Find in Model View	Select this command to locate the selected element in the Model View tree.
<a href="#">Properties</a>	Opens the Property View dialog for the selected element.

## Usage





You can show the create, read, update, or delete database attributes on a connection. When this connection is created they are labeled with the attributes you selected at the time of creation. These elements can consist of reference objects, data objects, and elements within a diagram.

Shortcut Menu Item	Description
Show	Name (Type) Usage
Appearance...	Opens the Appearance tab in the Property View where you can edit the font and color options, Diagram display options, and Line display options of the object.
Connections	<p>If you right-click on a connection (for example a Sequence Flow) you get the following commands:</p> <p>Hide Selected: The selected connection no longer appears in the diagram.</p> <p>Show Attached/Hide Attached:</p> <ul style="list-style-type: none"> <li>• If it is a Business Process diagram, the command shows or hides the following: All, Associations, Line Shapes, Links, Message Flows, Sequence Flows, or Usages.</li> <li>• If it is a Conceptual Model diagram, the command shows or hides the following: All, Interactions, Line Shapes, Links, Relationships, or Usages.</li> </ul>
Edit	This opens a pull-right menu allowing you to delete, or select all elements in the diagram.
Layout	<p>You can change the layout on individual connections. The commands e available on the pull-right menu are:</p> <p>Curved: Orthogonal bend points with "curved" corners are placed on the line.</p> <p>Elbowed: Orthogonal bend points are placed on the line.</p> <p>Straight: The line is always straight. However there can be bend points on the connection.</p> <p>Remove Bend Points: Removes all bends so the line traverses the shortest distance between two elements.</p> <p>Reset to Default Docking Position: The docking position of the line/element intersection is reset to its default setting.</p>

Shortcut Menu Item	Description
Find in Model View	Select this command to locate the selected element in the Model View tree.
<a href="#">Properties</a>	Opens the Property View dialog for the selected element.





## External Data Objects

The shortcut menu for all of the External Data Objects contains the same commands.

Shortcut Menu Item	Icon	Description
Show Name		This is a toggle command. If it is selected the element label shows.
Appearance...		Opens the Appearance tab in the Property View where you can edit the font and color options, horizontal alignment, and Diagram display options of the object.
Connections		This command shows or hides the following connection objects: All, Interactions, Line Shapes, Links, Relationships, or Usages.
<a href="#">Grouping</a>		Group: Groups two or more selected elements into a single entity that can be moved around a diagram in a block. Ungroup: Removes the selected grouping. This command is available only if the element selected is in a group.
Align Objects		When two or more objects are selected, the <a href="#">alignment</a> commands are available on a pull-right menu.
Order		This is a pull-right menu displaying two commands that control stacking of elements in the Diagram View: Bring to Front and Send to Back.
Edit		This opens a pull-right menu allowing you to cut, copy, paste, delete, or select all elements in the diagram.
Links		If you are creating a new link, click Links>New and the <a href="#">Create Link</a> wizard opens. If you are editing an existing link, click Links>Edit. If there are multiple links, the pull-right menu displays a list of the existing links. Click the name on the pull-right and the <a href="#">Edit Link</a> wizard opens. If there is only one link the command is Links>Edit. You can also select to show or hide the link in the Diagram View.
Usage (CRUD)		If you are creating a new usage, click Usage>New and the <a href="#">Usages</a> wizard opens. If you want to edit or view an existing usage, click Usage (CRUD)>Edit or View. The Usage (CRUD) tab opens in the Property View for the selected element. You can also select to show or hide the Usage in the Diagram View.
Impact Analysis		You have two commands available from the pull-right menu: You can generate an <a href="#">Impact Analysis Diagram</a> which graphically displays all the associated relationships and elements. You can also show the <a href="#">Impact Analysis Report</a> .
Find in Model View		Select this command to locate the selected element in the Model View tree.
<a href="#">Properties</a>		Opens the Property View dialog for the selected element.

## Drawing Shapes

The shortcut menu for all the Drawing Shapes contains the same commands with the exception of the [Line](#).

Shortcut Menu Item	Icon	Description
Show Name		This is a toggle command. If it is selected the element label shows.
Appearance...		Opens the Appearance tab in the Property View where you can edit the font and color options, horizontal and vertical alignment, Diagram display options, and Line display options of the object.
Connections		This command shows or hides connection objects. For conceptual diagrams the following connections are listed: All, Line Shapes, Links, or Usages. For business process diagrams the following connections are listed: All, Associations, Line Shapes, Links, Message Flows, Sequence Flows, and Usages.
<a href="#">Grouping</a>		Group: Groups two or more selected elements into a single entity that can be moved around a diagram in a block. Ungroup: Removes the selected grouping. This command is available only if the element selected is in a group.
Align Objects		When two or more objects are selected, the <a href="#">alignment</a> commands are available on a pull-right menu.
Order		This is a pull-right menu displaying two commands that control stacking of elements in the Diagram View: Bring to Front and Send to Back.
Edit		This opens a pull-right menu allowing you to cut, copy, paste, delete, or select all elements in the diagram.
Links		If you are creating a new link, click Links>New and the <a href="#">Create Link</a> wizard opens. If you are editing an existing link, click Links>Edit. If there are multiple links, the pull-right menu displays a list of the existing links. Click the name on the pull-right and the <a href="#">Edit Link</a> wizard opens. If there is only one link the command is Links>Edit. You can also select to show or hide the link in the Diagram View.
Usage (CRUD)		If you are creating a new usage, click Usage>New and the <a href="#">Usages</a> wizard opens. If you want to edit or view an existing usage, click Usage (CRUD)>Edit or View. The Usage (CRUD) tab opens in the Property View for the selected element. You can also select to show or hide the Usage in the Diagram View.
Impact Analysis		You have two commands available from the pull-right menu: You can generate an <a href="#">Impact Analysis Diagram</a> which graphically displays all the associated relationships and elements. You can also show the <a href="#">Impact Analysis Report</a> .
Find in Model View		Select this command to locate the selected element in the Model View tree.
<a href="#">Properties</a>		Opens the Property View dialog for the selected element.

## Line

The Line has a different set of commands available because of its different characteristics.

Shortcut Menu Item	Description
Show Name	This is a toggle command. If it is selected the element label shows.
Appearance...	Opens the Appearance tab in the Property View where you can edit the font and color options, Diagram display options, and Line display options of the object.
Connections	<p>If you right-click on a connection (for example a Sequence Flow) you get the following commands:</p> <p>Hide Selected: The selected connection no longer appears in the diagram. Show Attached/Hide Attached:</p> <ul style="list-style-type: none"> <li>• If it is a Business Process diagram, the command shows or hides the following: All, Associations, Line Shapes, Links, Message Flows, Sequence Flows, or Usages.</li> <li>• If it is a Conceptual Model diagram, the command shows or hides the following: All, Interactions, Line Shapes, Links, Relationships, or Usages.</li> </ul>
Edit	This opens a pull-right menu allowing you to cut, copy, paste, delete, or select all elements in the diagram.
Layout	<p>You can change the layout on individual connections. The commands available on the pull-right menu are:</p> <p>Curved: Orthogonal bend points with “curved” corners are placed on the line. Elbowed: Orthogonal bend points are placed on the line. Straight: The line is always straight. However there can be bend points on the connection. Remove Bend Points: Removes all bends so the line traverses the shortest distance between two elements. Reset to Default Docking Position: The docking position of the line/element intersection is reset to its default setting.</p>
Find in Model View	Select this command to locate the selected element in the Model View tree.
<a href="#">Properties</a>	Opens the Property View dialog for the selected element.

## Keyboard commands

The application keyboard commands help you expedite your tasks by minimizing mouse clicks.

Command	Description
<a href="#">Hot-Key Object Movement</a>	You can move objects by pre-set increments using the specified hot keys.
<a href="#">Eclipse Hot-Key Object Movement</a>	You can use the hot-keys to move the elements or connections, but the key combination is different
<a href="#">Selecting Objects in Container Elements</a>	You can select objects in a container element such as a Subject Area by using the Alt key.
<a href="#">Key Assist Commands</a>	This is a list of “hot” keys or shortcuts used by ER/Studio BA.

## Hot-Key Object Movement

This allows you to move elements and connectors in the Diagram View using specified hot keys. You can change the default setting for the hot-key object movement in the [Preferences Editor](#).

1. From the main menu choose Windows > Preferences.
2. Select Diagrams. The default setting for "Override Eclipse hot-key object movement" is enabled.

When the hot-key movement is overridden you can move elements and connections in the Diagram View using the arrow keys.

Action	Key Combination
Directional arrow key only	Each time you click a directional arrow, the element or connection is moved one pixel in the direction of the arrow.
Shift + directional arrow	While holding down the Shift key, each time you click a directional arrow, the element or connection is moved ten pixels in the direction of the arrow.
Ctrl + directional arrow	While holding down the Ctrl key, each time you click a directional arrow, the element or connection is moved 20 pixels in the direction of the arrow.

**NOTE:** If this preference is not enabled, the directional arrow keys are used to move between elements on the diagram.

## Eclipse Hot-Key Object Movement

When the override preference is not selected, you can still use the hot-keys to move the elements or connections, but the key combination is different.

1. Select the element that you want to move.
2. Press the period key and a directional arrow.

**NOTE:** Notice that the element changes color when it is in the move mode.



3. Each time you click a directional arrow, the element is moved one pixel in the direction of the arrow.
4. When you press the period key again, you are taken out of the move function to the resize function.
5. Each time you press the period key, the resize cursor moves to a different resize point on the element.

## Selecting Objects in Container Elements

You can select multiple elements that have been placed in container elements.

1. To invoke the marquee cursor, hold down the ALT key while dragging the mouse around the items you want selected with the container.

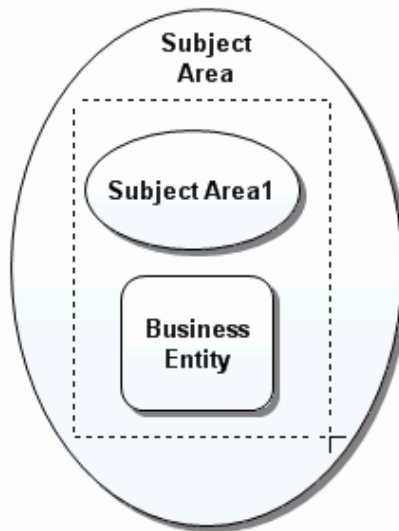

2. Release both the ALT key and the mouse button and the items within the frame are selected.

**NOTE:** The container elements used in ER/Studio BA consist of: Subject Area, Business Entity, Pool/Lane, and Embedded Subprocess.

### Key Assist Commands

ER/Studio BA offers the following general shortcuts/accelerators for the application. Select Ctrl + Shift + L to open the list of Key Assist Commands in the application. The table below describes the keyboard commands:

Result	Keyboard Command
Activate Editor	F12
Backward History	Alt+Left
Bold	Ctrl+B
Close	Ctrl+W
Close All	Ctrl+Shift+F4
Content Assist	Ctrl+Space
Context Information	Ctrl+Shift+Space
Console	Alt+Shift+Q, C
Copy	Ctrl+C
Cut	Shift+X
Group	Ctrl+Shift+G
Italics	Ctrl+I
Last Edit Location	Ctrl+Q



Result	Keyboard Command
Maximize Active View or Editor	Ctrl+M
New Workspace	Ctrl+N
New Menu	Alt+Shift+N
Next	Ctrl+.
Next Editor	Ctrl+F6
New Perspective	Ctrl+F8
Next View	Ctrl+F7
Open Editor Drop Down	Ctrl+E
Open Property View from Grid Editor	Alt+Enter
Open Resource	Ctrl+Shift+R
Open Workspace	Ctrl+0
Paste	Shift+V
Previous	Ctrl+,
Previous Editor	Ctrl+Shift+F6
Previous Perspective	Ctrl+Shift+F8
Previous View	Ctrl+Shift+F7
Print	Ctrl+P
Properties	Alt+Enter
Quick Fix	Ctrl+1
Redo	Ctrl+Y
Refresh	F5
Rename	F2
Save	Ctrl+S
Save All	Ctrl+Shift+S
Select All	Ctrl+A
Select All text in Notes and Description Fields	Ctrl+A
Select Element	Shift+Click
Show In Menu	Alt+Shift+W
Show Key Assist	Ctrl+Shift+L
Show System Menu	Alt+-
Show View (View: Outline)	Alt+Shift+Q, O
Show View (View: Problems)	Alt+Shift+Q, X
Show View Menu	Ctrl+F10
Switch to Editor	Ctrl+Shift+E
Underline	Ctrl+U
Undo	Ctrl+Z
Ungroup	Ctrl+Shift+U
Zoom In	Ctrl+=
Zoom Out	Ctrl+-

# Preferences

You can configure many of ER/Studio BA's properties to better suit your workflow and your work goals. The application offers a number of configuration options from different locations.

You can customize the application configuration to meet your specific needs. You do this using the Preferences Editor, where you set your preferences for the application's global defaults. You can also use this dialog to add, edit, and delete selected default values.

## Preferences Editor

You can use the Preferences Editor to make changes to defaults used application-wide. You can also edit default values.

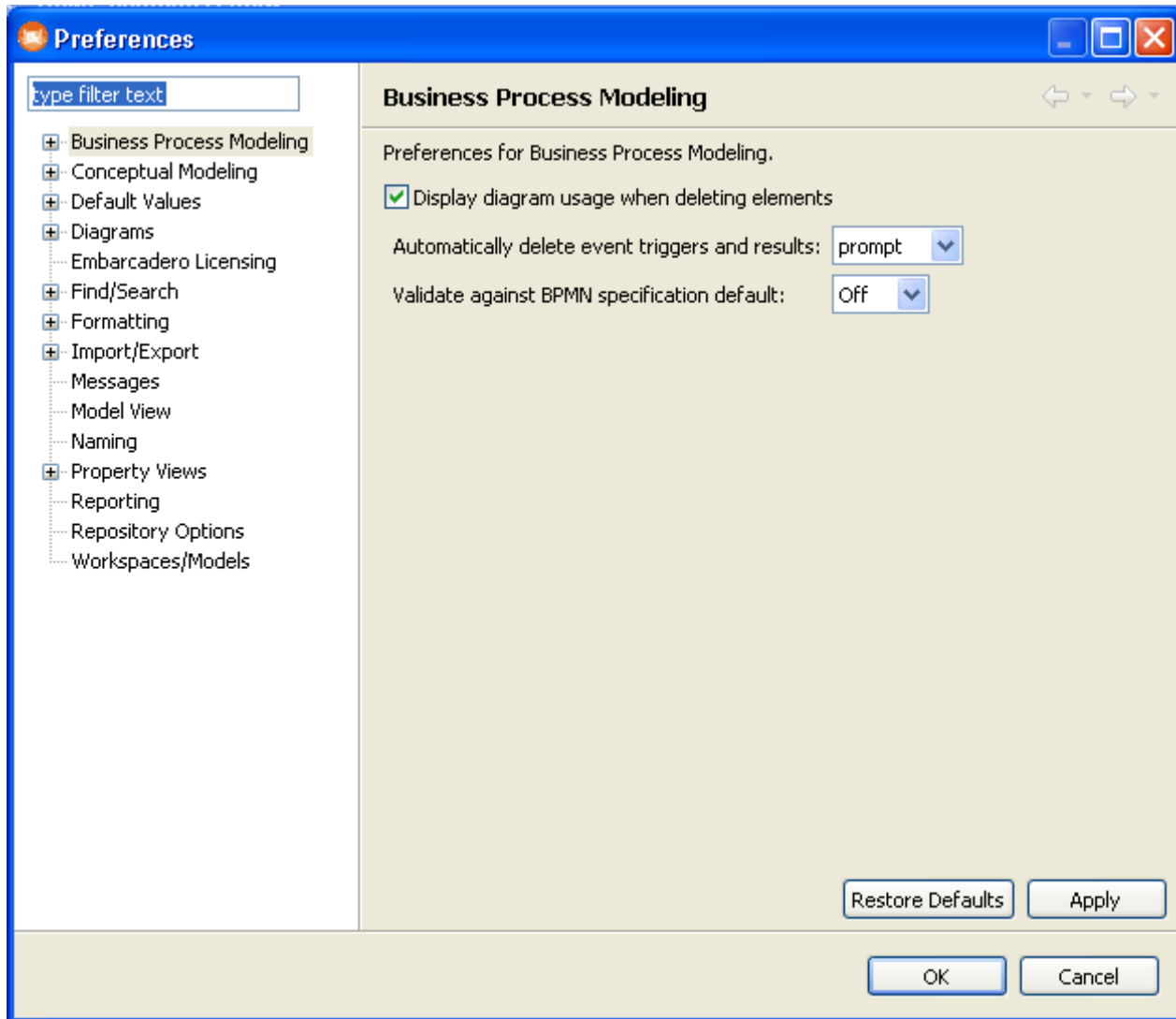

The table below describes the components in the Preferences Editor:

Component	Description
type filter text	This is a search text box which enables you to quickly locate the preference you want to change. The item you are searching for appears in the Categories tree.
Categories tree	Displays in tree form all preferences available for editing, adding, or deleting. Expand the nodes of this tree to display each node's defaults in the Details grid.
Details pane	Lists all options and their default values for any node selected in the Categories tree.
Apply to Diagram	This button is available on applicable preferences (for example Formatting). It applies the changes immediately to the open diagram. <b>Note:</b> The Apply to Diagram function does not apply to the Display Options command for existing elements in a diagram.
Restore Defaults	Restores the default values for all preferences on the opened preference page, and displays a warning message explaining the repercussions of the restoration.
Apply	Click Apply to institute the changes you made in the Preferences dialog.
OK	Accepts all the changes made and closes the dialog.
Cancel	Cancels all changes made and closes the dialog.

### Opening the Preferences Editor

1. On the main menu, click Window > Preferences....
2. To locate the preference you want to change, you can type the preference name in the Type Filter Text box and press Enter. The preference appears in the Categories tree.  
OR  
Expand the nodes in the Categories tree and select the preference you want to edit.
3. In the Details pane, edit the settings you want to change.  
**NOTE:** When working Formatting Preferences, if you are changing preferences in multiple panes, you must click Apply before going to the next pane or all formatting changes to the object is lost.
4. Click OK and ER/Studio BA saves your changes and the Preferences dialog closes. You can set preferences for behavior and appearance in the ER/Studio BA application.

The nodes available are:

- [Business Process Modeling](#)
- [Conceptual Modeling](#)
- [Default Values](#)
- [Diagrams](#)
- [Find/Search](#)
- [Formatting](#)
- [Import/Export](#)
- [License Manager](#)
- [Messages](#)

- [Model View](#)
- [Naming](#)
- [Property Views](#)
- [Reporting](#)
- [Repository Options](#)
- [Workspaces/Models](#)

## Business process modeling

In this node you can set preferences that directly affect the Business Process Modeling Notation elements. The table below describes the details available for the Business Process Modeling node.

Detail	Description
Display Diagram Usage When Deleting Elements	If you select this preference, the Delete dialog displays the following option: "Click here to see the diagrams on which the elements appear." When you click  , a box opens showing a list of the other diagrams that are using this object.
Automatically Delete Event Triggers and Results	You have two options when deleting a trigger/result from an event: Prompt: A Delete dialog will always open warning you that all event triggers/results along with their associated information will be deleted. When you select OK, the trigger/result(s) are removed from the event. Always: The trigger/result(s) are deleted without a warning dialog. The default setting is Prompt.
<a href="#">Validating Against BPMN Specification</a>	When you create a new project, this validation preference sets the default value (on or off) in the New Project Wizard dialog.

There are two subnodes listed in the Business Processing Modeling node: [Pools](#) and [Processes](#).

### Pools

The Pools preference has one setting:

Detail	Description
Adjust pool size when resizing lanes	When this option is selected (default setting) if you increase the size of a lane, the pool increases in size as well. If you deselect this preference, you won't see the pool grow in size and the lane above or below it will shrink.

### Processes

The Processes preference has one setting:

Detail	Description
Show <a href="#">Processes</a> in Application	Select this option to display elements in a diagram or pool under the Process node (  ) in the Model View. If this option is not selected, all elements are displayed under the Pool node.

## Conceptual modeling

Expand the Conceptual Model node to gain access to the subnode Bindings. The table below describes the preferences available for bindings.

Detail	Description
Duplicate attribute warning options	
Automatically create business attributes from business elements	<p>You have two settings on how you want to handle the binding of business elements to business attributes:</p> <p>Prompt: A Binding Creation Warning dialog will always open prompting you for a decision on how to handle business attributes that already exist with the same name.</p> <p>Always: If a bound business attribute with the same already exists in the business entity, a new bound business attribute will always be created with a unique name. When this option is selected, the second preference is made available.</p> <p>The default setting is Prompt.</p>
Create the new attribute with a unique name and bind it to the business element	This option is enabled if the "Always" preference is selected. Select it if you want all newly created attributes to have unique names and automatically bound to the business element.
Create the new attribute with a unique name but do not bind it to the business element	This option is enabled if the first preference is selected. Select it if you want all newly created attributes to have unique names, but do not want it automatically bound to the business element.
Display warning when attempting to bind a business element and domain to an attribute	You cannot bind both a Business Element and a Domain to an attribute. A warning dialog opens giving you an opportunity to resolve the conflict. You can deselect this option to hide this warning.

## Default values

The preferences in this section set default values for metadata objects. You can set these values for [Attributes](#), [Business Attributes](#), [Business Elements](#), [Columns](#), and [Domains](#).

### Attributes

The table below describes the preference available for the Attributes node:

Detail	Description
Data Type	Select the default value you want to always appear for Attributes. You can select: None, Binary, Boolean, Char, Date, Decimal, Float, Integer, Long Binary, Money, Timestamp, Varchar, and XML.
Width	Set the default length of the attribute/domain datatype.
Scale	Set the default number of digits after a decimal (for those data types that imply a decimal).

## Business attributes

The table below describes the preference available for the Business Attributes node:

Detail	Description
Data Type	Select the default value you want to always appear for Business Attributes. You can select: None, Binary, Boolean, Char, Date, Decimal, Float, Integer, Long Binary, Money, Timestamp, Varchar, and XML.
Width	Set the default length of the attribute/domain datatype.
Scale	Set the default number of digits after a decimal (for those data types that imply a decimal).

## Business elements

The table below describes the preference available for the Business Elements node:

Detail	Description
Data Type	Select the default value you want to always appear for Business Elements. You can select: None, Binary, BLOB/Image, Boolean, Char, CLOB/Large Text, Date, Decimal, Integer, Timestamp, Varchar, and XML.

## Columns

The table below describes the preference available for the Columns node:

Detail	Description
Data Type	Select the default value you want to always appear for Columns You can select: None, Binary, Boolean, Char, Date, Decimal, Float, Integer, Long Binary, Money, Timestamp, Varchar, and XML.
Width	Set the default length of the attribute/domain datatype.
Scale	Set the default number of digits after a decimal (for those data types that imply a decimal).

## Domains

The table below describes the preferences available for the Domains node:

Detail	Description
Data Type	Select the default value you want to always appear for Domains. You can select: None, Binary, BLOB/Image, Boolean, Char, CLOB/Large Text, Date, Decimal, Integer, Timestamp, Varchar, and XML.
Width	Set the default length of the attribute/domain datatype.
Scale	Set the default number of digits after a decimal (for those data types that imply a decimal).
Optionality	Select the optionality you want to always appear for Domains. Your choices are: None, Mandatory, or Optional.

## Diagrams

You can set global preferences for three main diagram preferences. You can also set a preference for the generation of [Impact Analysis Diagrams](#). The table below describes the preferences available for the Diagrams node:

Detail	Description
Options for All Diagrams	
Automatically perform diagram layout	You have two options for the type of notification you get when right-clicking in a diagram and selecting one of the Layout options: prompt, and always. The default setting is Prompt.
Enable multi-drop on object creation	Select this preference to enable the multi-drop mode. When you select an element from the Palette view, the cursor is in the multi-drop mode  . So, you can place as many elements as you need. This preference is selected as the default setting.
Override Eclipse hot-key object movement	Select this option to override the Eclipse <a href="#">Hot-Key Object Movement</a> . This allows you to use the directional keys to move elements in the Diagram View.
Options for New Diagrams	
Default Line Layout	When creating a new diagram, you can set the default line style used when you create a connecting object between two objects. Your three options are curved, elbowed, or straight. The default setting is curved.
Default Case Shift	When creating a new diagram, you can set the default case shift for all element labels. You have three options: Lower: All text appears in lower case lettering, including the initial letter of the label. Preserve: Text is preserved as it was entered. Upper: All text appears in upper case lettering. The default setting is "Preserve."
Show Grid Lines	Changes the default setting so that each time a diagram is opened or a new diagram is created, the grid lines automatically appear.
Show parent objects as transparent when grid lines are displayed	When a parent object such as a pool or lane is placed on a diagram, the grid lines appear in the object, i.e. the object is transparent.
Snap Objects to Grid	Changes the default setting so that when an element is placed in the Diagram View, it automatically snaps to the nearest grid. When an element is moved, it also snaps to the nearest grid line.
General Preferences	
Open last used diagram when starting application	The last used diagram opens when the workspace is opened. This option is selected by default.

## Impact Analysis diagrams

The table below describes the preference available for Impact Analysis diagrams:

Detail	Description
Automatically generate large Impact Analysis Diagrams	Select this option if you always want Impact Analysis Diagrams of any size automatically generated. If this option is not selected you are given the option whether to generate a large diagram or not.

## Find/Search

There are two sets of preferences you can set: Search Dialog and Search Results.

### Search dialog

The one preference for the Search Dialog lets you set the number of entries you want to appear in the search history list.

### Search results

There are two preferences you can set for the Search Results view:

Preference	Description
Maximum number of elements to return	Enter the maximum number of returns to show for a search. The preference would be helpful if you are search large models with many elements.
Display Options	You can select which columns you want to appear in the Search Results view. Your options are: Name, Type, Description, Notes, Parent, and Project Hierarchy.

## Formatting

You can set global preferences for the following element types:

- [Business Process Modeling Formatting](#)
- [Conceptual Modeling Formatting](#)
- [External Data Objects Formatting](#)
- [Reference Objects Formatting](#)
- [Shapes Formatting](#)

The changes you make in these preference dialogs are then applied to all future elements you place in the Diagram View. For example, if you change the fill color of a gateway to red. Now all gateways you place in the diagram View will be red. The preferences you can set are fonts and colors, text justification, rendering, display option settings, and line display options.

To open the Formatting Preferences dialog, do the following:

1. From the main menu select Windows > Preferences.
2. Expand the Formatting node and select element types you want to format (i.e., Business Process Modeling, Conceptual Modeling, External Data Objects, etc.).



Once you select the type of elements you want to format, additional information appears where you can specify display format defaults for a selected element. The formatting options are explained below:

Detail	Description
Tree	The Tree contains the set of business processing modeling elements which have visual formatting preferences set. This is anything which can be viewed in a diagram and printed. When you open the Formatting Preferences, all available elements are listed.
<a href="#">Font and Color Options</a>	Once you select an object in the List Pane, you can change the following settings: font type, font size, font style, and font color. You can also change an element's fill color and line color.
<a href="#">Horizontal Alignment</a>	You can set the justification style for text in a selected element.
<a href="#">Vertical Alignment</a>	You can set the top to bottom alignment of text in a selected element.
<a href="#">Rendering</a>	You can set the appearance of a selected element using the shadowed and gradient settings.
Display Options	The Show Name on Creation option displays an element's name when that element is placed on a diagram.  Note: This only applies to newly created elements on a diagram. Existing elements are not updated when you click the Apply to Diagram button.
<a href="#">Line Display Options</a>	Depending on the element you are formatting, you can change the following: line width, source decorator, source decorator size, line style, target decorator, and target decorator size.

Each dialog offers action buttons. The table below describes each button:





Button	Description
Apply to Diagram	Applies the changes immediately to elements in an open diagram.  Note: The Apply to Diagram function does not apply to the Display Options command for existing elements in a diagram.
Restore Defaults	Restores formatting of the element to the application defaults.
Apply	Applies your specifications without closing the dialog box.
OK	Applies your specifications, and then closes the dialog box.
Cancel	Closes the Preferences dialog and cancels all changes made in the Formatting dialog, unless something has been applied earlier.

## Business Process Modeling formatting



This is where you can set global preferences for Business Process Modeling Notation (BPMN) elements. You can set [Font and Color Options](#), [Horizontal Alignment](#), [Vertical Alignment](#), [Rendering](#), [Display Options](#), and [Line Display Options](#). The availability of the formatting elements depends on the element you select.

## Font and color options

You can change the font style, font size, and font colors. You can also change the fill and line colors of a selected element in the Font and Color portion of the Formatting dialog.



Command	Icon	Description
Front Style		Select a new font style from the drop- down list.
Front Size		Select a new font size from the drop- down list.
Bold		Applies bold formatting to the label text.
Italics		Italicizes the label text.
Underline		Underlines the label text.
Strikeout		A line is drawn through the label text.

You can also change the font color, element outline color, and element fill color.

Command	Icon	Description
Change Font Color		Opens the Color dialog. You can select an existing color or create a custom color for the color of the label font.
Change Line Color		Opens the Color dialog. You can select an existing color or create a custom color for the border of the element.
Change Fill Color		Opens the Color dialog. You can select an existing color or create a custom color for the background of the element.



## Horizontal alignment

You can change the justification setting for the text label in an element.

Command	Icon	Description
Left Justify Text		Justifies the text on the left side of the text box.
Center Text		Centers the text within the text box.
Right Justify Text		Justifies the text on the right side of the text box.

## Vertical alignment

You can change the top to bottom alignment settings for the text label in an element.

Command	Icon	Description
Top		Places the text in the top portion of the element.
Center		Centers the text within the element.
Bottom		Places the text in the bottom portion of the element.

## Rendering

There are two commands available that affect the appearance of elements in the Diagram View:

Command	Description
Shadowed	When this option is selected the element has a slight shadowed background. The Shadowed option is the default setting.
Gradient	When this option is selected the element has gradient shading. If it is not selected the element is a solid color. The Gradient option is the default setting.

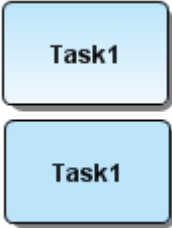

## Display options

The Show Name on Creation option displays an element's name when that element is placed on a diagram.

**NOTE:** This only applies to newly created elements on a diagram. Existing elements are not updated when you click the Apply to Diagram button.

## Line display options

You can set the line display preferences for the Sequence Flow, Message Flow, and Association objects. Not all preferences are available for all objects.





Command	Description
Line Width	This preference sets the width of an interaction or relationship in a diagram. Select 1 through 5 pixels from the drop-down list box. This preference is available for the Sequence Flow, Message Flow, and Association.
Line Style	Choose a line style from the drop-down list. You can select from one of five different styles from the drop down list. The list includes solid, dash, dot, dash-dot, and dash-dot-dot.
Source Decorator Size	You can set the size of the target decorator. This option is available for the Message Flow element.
Target Decorator Size	You can set the size of the target decorator. This option is available for the Sequence Flow, and Message Flow elements.

## Conceptual Modeling formatting



This is where you can set global preferences for conceptual Data Modeling elements. The following preferences can be set: [Font and Color Options](#), [Horizontal Alignment](#), [Vertical Alignment](#), [Rendering](#), [Diagram Display Options](#), [Shape](#), and [Line Display Options](#). The availability of the formatting elements depends on the element you select.

### Font and color options

You can change the font style, font size, and font colors. You can also change the fill and line colors of a selected element in the Fonts and Colors portion of the Formatting dialog.



Command	Icon	Description
Front Style		Select a new font style from the drop- down list.
Front Size		Select a new font size from the drop- down list.
Bold		Applies bold formatting to the label text.
Italics		Italicizes the label text.
Underline		Underlines the label text.
Strikeout		A line is drawn through the label text.

You can also change the font color, element outline color, and element fill color.

Command	Icon	Description
Change Font Color		Opens the Color dialog. You can select an existing color or create a custom color for the color of the label font.
Change Line Color		Opens the Color dialog. You can select an existing color or create a custom color for the border of the element.
Change Fill Color		Opens the Color dialog. You can select an existing color or create a custom color for the background of the element.



### Horizontal alignment

You can change the justification setting for the text label in an element.

Command	Icon	Description
Left Justify Text		Justifies the text on the left side of the text box.
Center Text		Centers the text in the text box.
Right Justify Text		Justifies the text on the right side of the text box.

## Vertical alignment

You can change the top to bottom alignment settings for the text label in an element.

Command	Icon	Description
Top		Places the text in the top portion of the element.
Center		Centers the text within the element.
Bottom		Places the text in the bottom portion of the element.

## Rendering

There are two commands available that affect the appearance of elements in the Diagram View:

Command	Description
Shadowed	When this option is selected the element has a slight shadowed background. The Shadowed option is the default setting.
Gradient	When this option is selected the element has gradient shading. If it is not selected the element is a solid color. The Gradient option is the default setting.

## Diagram display options

You can set the global preferences for the objects. Not all options are available for all objects.

Command	Description
Show Name on Creation	The Show Name on Creation option displays an element's name when that element is placed on a diagram. Applies to all Conceptual Modeling elements.
Show Unique Identifier	You can show or hide the Unique Identifier indicator (#) on Business Attributes. For a Relationship, you can control whether or not to display the unique identifier source decorator by default.
Show Expansion Control	This preference can be set for the Business Entity and Subject Area only. Select this option to display the "+" or "-" indicator in the element. This option is not selected by default.
Show Business Attributes	Displays the Business Attributes in a Business Entity element. This preference applies only to the Business Entity element.
Align Attributes to Top	As you add attributes they are stacked at the top of the Business Entity. If this preference is not selected, attributes are added from the bottom up. This preference applies only to the Business Entity element.
Show Optionality	If an <a href="#">Optionality</a> type is set for a Business Attribute, you can set the preference to always show the indicator. This preference applies only to the Business Entity element.

**NOTE:** This only applies to newly created elements on a diagram. Existing elements are not updated when you click the Apply to Diagram button.

## Shape

You can change the shape for a Subject Area element.

Command	Description
Oval	Element appears as an elongated circle in the Diagram View.
Rectangle	Element appears as a rectangle in the Diagram View.

## Line display options

You can set the line display preferences for the Business Entity, Subject Area, Interaction and Relationship objects.

Command	Description
Line Width	This preference sets the width of a border on an element, or an interaction or relationship in a diagram. Select 1 through 5 pixels from the drop- down list box.
Line Style	This preference sets the line style of an interaction or relationship in a diagram. You can select from one of five different styles from the drop down list. The list includes solid, dash, dot, dash-dot, and dash-dot-dot.
Source Decorator	Set the preference for the beginning or source of an interaction or relationship connection in a diagram. Your five options are None, Arrow, Diamond, Crows Feet, Triangle, or Hollow Circle.
Target decorator	Set the preference for the end or target of an interaction connection in a diagram. Your five options are None, Arrow, Diamond, Crows Feet, Triangle, or Hollow circle.
Target Decorator Size	You can set the size of the target decorator for the Interaction element.



## External Data Objects formatting

This is where you can set global preferences for External Data Object elements. For all External Data Objects you can set [Font and Color Options](#), [Horizontal Alignment](#), [Vertical Alignment](#), and [Display Options](#). The availability of the formatting elements depends on the element you select.



### Font and color options

You can change the font style, font size, and font colors. You can also change the fill and line colors of a selected element in the Fonts and Colors portion of the Formatting dialog.

Command	Icon	Description
Font Style		Select a new font style from the drop- down list.
Font Size		Select a new font size from the drop- down list.
Bold		Applies bold formatting to the label text.



Command	Icon	Description
Italics		Italizes the label text.
Underline		Underlines the label text.
Strikeout		A line is drawn through the label text.

You can also change the font color, element outline color, and element fill color.

Command	Icon	Description
Change Font Color		Opens the Color dialog. You can select an existing color or create a custom color for the color of the label font.
Change Line Color		Opens the Color dialog. You can select an existing color or create a custom color for the border of the element.
Change Fill Color		Opens the Color dialog. You can select an existing color or create a custom color for the background of the element.



### Horizontal alignment

You can change the justification setting for the text label in an element.

Command	Icon	Description
Left Justify Text		Justifies the text on the left side of the text box.
Center Text		Centers the text in the text box.
Right Justify Text		Justifies the text on the right side of the text box.

### Vertical alignment

You can change the top to bottom alignment settings for the text label in an element.

Command	Icon	Description
Top		Places the text in the top portion of the element.
Center		Centers the text within the element.
Bottom		Places the text in the bottom portion of the element.

## Display options

The Show Name on Creation option displays an element's name when that element is placed on a diagram.

**NOTE:** This only applies to newly created elements on a diagram. Existing elements are not updated when you click the Apply to Diagram button.





## Reference Objects formatting

This is where you can set global preferences for Reference Object elements. For all Reference Objects you can set [Font and Color Options](#), [Horizontal Alignment](#), [Vertical Alignment](#), and [Diagram Display Options](#). You can also set [Line Display Options](#) for the Link and Usage Reference Objects. The availability of the formatting elements depends on the element you select.



**NOTE:** Since Domains are not visualized on a diagram, you cannot set formatting preferences for them.

## Font and color options

You can change the font style, font size, and font colors. You can also change the fill and line colors of a selected element in the Fonts and Colors portion of the Formatting dialog.

Command	Icon	Description
Front Style		Select a new font style from the drop- down list.
Front Size		Select a new font size from the drop- down list.
Bold		Applies bold formatting to the label text.
Italics		Italicizes the label text.
Underline		Underlines the label text.
Strikeout		A line is drawn through the label text.



You can also change the font color, element outline color, and element fill color.

Command	Icon	Description
Change Font Color		Opens the Color dialog. You can select an existing color or create a custom color for the color of the label font.
Change Line Color		Opens the Color dialog. You can select an existing color or create a custom color for the border of the element.
Change Fill Color		Opens the Color dialog. You can select an existing color or create a custom color for the background of the element.





## Horizontal alignment

You can change the justification setting for the text label in an element.

Command	Icon	Description
Left Justify Text		Justifies the text on the left side of the text box.
Center Text		Centers the text in the text box.
Right Justify Text		Justifies the text on the right side of the text box.

## Vertical alignment

You can change the top to bottom alignment settings for the text label in an element.

Command	Icon	Description
Top		Places the text in the top portion of the element.
Center		Centers the text within the element.
Bottom		Places the text in the bottom portion of the element.

## Diagram display options

You can set preferences for what you want displayed on creation of a reference object.

Command	Description
Show Name on Creation	Displays an element's name when that element is placed on a diagram. This preference is available for all reference objects.
Show Usage on Creation	Displays the Usage settings when a usage is created on the diagram (C=Create, R=Read, U=Update, and D=Delete). This preference is available only for the Usage reference object.

**NOTE:** These only apply to newly created elements on a diagram. Existing elements are not updated when you click the Apply to Diagram button.

## Line display options

You can set preferences for the Link and Usage Reference objects.

Command	Description
Line Width	This preference sets the width of an interaction or relationship in a diagram. Select 1 through 5 pixels from the drop-down list box. This is the only line display option you can set for a Link.
Line Style	This preference sets the line style of an interaction or relationship in a diagram. You can select from one of five different styles from the drop down list. The list includes solid, dash, dot, dash-dot, and dash-dot-dot. This applies only to a Usage.

Command	Description
Source Decorator	Set the preference for the beginning or source of an interaction or relationship connection in a diagram. Your five options are None, Arrow, Diamond, Crows Feet, Triangle, or Hollow Circle. This applies only to a Usage.
Target decorator	Set the preference for the end or target of an interaction connection in a diagram. Your five options are None, Arrow, Diamond, Crows Feet, Triangle, or Hollow circle. This applies only to a Usage.





## Shapes formatting

This is where you can set global preferences for drawing shapes. For all Shapes you can set [Font and Color Options](#), [Horizontal Alignment](#), [Vertical Alignment](#), [Rendering](#), [Display Options](#) and [Line Display Options](#). The availability of the formatting elements depends on the element you select.



### Font and color options

You can change the fonts, font size, font colors, and the fill and line colors of a selected element in the Colors and Fonts portion of the Formatting dialog.

To change the font, select a font from the drop-down menu in the Font text box. You can also change the font size by selecting a size from the drop-down menu in the size text box. You can edit the font settings of all element labels. The following commands are available:

Command	Icon	Description
Front Style		Select a new font style from the drop- down list.
Front Size		Select a new font size from the drop- down list.
Bold		Applies bold formatting to the label text.
Italics		Italicizes the label text.
Underline		Underlines the label text.
Strikeout		A line is drawn through the label text.



You can also change the font color, element outline color, and element fill color with the following.

Command	Icon	Description
Change Font Color		Opens the Color dialog. You can select an existing color or create a custom color for the color of the label font.
Change Line Color		Opens the Color dialog. You can select an existing color or create a custom color for the border of the element.
Change Fill Color		Opens the Color dialog. You can select an existing color or create a custom color for the background of the element.

## Horizontal alignment



You can change the justification settings for the text label in an element.

**NOTE:** These commands do not justify the text labels on elements that use text boxes outside the element.

Command	Icon	Description
Left Justify Text		Justifies the text on the left side of the text box.
Center Text		Centers the text in the text box.
Right Justify Text		Justifies the text on the right side of the text box.

## Vertical alignment

You can change the top to bottom alignment settings for the text label in an element.

Command	Icon	Description
Top		Places the text in the top portion of the element.
Center		Centers the text within the element.
Bottom		Places the text in the bottom portion of the element.

## Rendering

There are two commands available that affect the appearance of elements in the Diagram View:

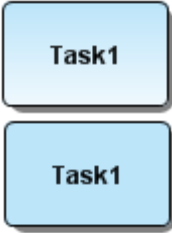
Command	Description
Shadowed	When this option is selected the element has a slight shadowed background. The Shadowed option is the default setting.
Gradient	When this option is selected the element has gradient shading. If it is not selected the element is a solid color. The Gradient option is the default setting. 
Transparent	The shapes have a transparent background when this preference is selected.
Transparent Line	This preference refers to the border of the text box. When placed in a pool, you can set the preference so the border does not show.

## Display options

The Show Name on Creation option displays an element's name when that element is placed on a diagram.

**NOTE:** This only applies to newly created elements on a diagram. Existing elements are not updated when you click the Apply to Diagram button.

## Line display options

You can set the line display preferences for the Line object.

Command	Description
Line Width	This preference sets the width of an interaction or relationship in a diagram. Select 1 through 5 pixels from the drop-down list box.
Line Style	This preference sets the line style of an interaction or relationship in a diagram. You can select from one of five different styles from the drop down list. The list includes solid, dash, dot, dash-dot, and dash-dot-dot.
Source Decorator	Set the preference for the beginning or source of an interaction or relationship connection in a diagram. Your five options are None, Arrow, Diamond, Crows Feet, or Triangle.
Target decorator	Set the preference for the end or target of an interaction or relationship connection in a diagram. Your five options are None, Arrow, Diamond, Crows Feet, or Triangle.

## Import/Export

You can set the default locations for importing workspaces and exporting workspaces, diagrams, and grid editors. Click Browse to open the Browse for Folder dialog.

Preference	Description
Default Export Location	Select the location where you want the exported files placed. The default location that appears in the Browse for Folder dialog is the My Documents folder.
Default Import Location	Select the location where the imported files reside. The default location that appears in the Browse for Folder dialog is the My Documents folder.

You can also set the following preferences:

- [Comma Separated Values Preferences](#)
- [ER/Studio Data Architect Preferences](#)
- [Impact Analysis Preferences](#)
- [Usage\(CRUD\) Preferences](#)
- [Visio Preferences](#)



## Comma Separated Values preferences

You can set import options when you are importing comma Separated Value files.

Preference	Description
Default Import Location	Select the location where the imported files reside. The default location that appears in the Browse for Folder dialog is the My Documents folder.

## ER/Studio Data Architect preferences

You can set export options when you are importing from and exporting to ER/Studio:

Preference	Description
Export Options	
Default export location	Select the location where you want the exported model placed. The default location that appears in the Browse for Folder dialog is the My Documents folder.
Installed version of ER/Studio Data Architect	You have three options: None, 7.0, and 7.1, 7.5. Choose 7.5 for versions 7.5 and later ER/Studio 7.0 does not support an XML data type. If this option is selected and the exported file contains a business attribute with an XML data type, it will be exported as VARCHAR. ER/Studio 7.1 supports XML data type and will be exported intact.
Automatically Open Generated Models in ER/Studio Data Architect	Select this option if you want ER/Studio Data Architect to open automatically after the export of a Conceptual Model. When this option is selected, the option in the Export to ER/Studio Data Architect dialog is also selected.
Import Options	
Default Import Location	Select the location where the ER/Studio Data Architect models reside. The default location that appears in the Browse for Folder dialog is the My Documents folder.
Import Domains as	Select the type of element you want domains imported as. Your choices are: Business Elements, Domains, and Business Elements Referencing Domains.

## Impact Analysis preferences

You can set import options when you are importing Impact Analysis report files.

Preference	Description
Default Import Location	Select the location where the imported files reside. The default location that appears in the Browse for Folder dialog is the My Documents folder.

## Usage (CRUD) preferences

You can set import options when you are importing Usage (CRUD) report files.

Preference	Description
Default Import Location	Select the location where the imported files reside. The default location that appears in the Browse for Folder dialog is the My Documents folder.

## Visio preferences

You can set import options when you are importing from Microsoft Office Visio®.

Preference	Description
Automatically Save Main Object Type Mapping	The Instance-level mappings are not saved as part of the custom mapping file. You have two options:  Prompt: The “Unable to Save Instance-Level Mappings” dialog always appears when you click Save, giving you the option to save or reject the current object type mappings.  Always: The current object type mappings are automatically saved without any warning.
Default Import Location	Select the location where the imported Visio files reside. The default location that appears in the Browse for Folder dialog is the My Documents folder.
Default Custom Mapping File Location	Select the location where you want to save your custom mapping settings when importing Visio models.
Retain Visio object sizes when creating presentation elements	Select this option to ensure that if a presentation element is resized in Visio, that resizing is carried over to ER/Studio BA.

## License Manager

You can set preferences for what licensing information you want logged.

Preference	Description
File Location	Set the file location of the License Manager log. You can change the location by clicking Browse to go to the Open dialog.
Mag Log Size (bytes)	The default log size is 1048576.
Log Options	You can select to display the following message types: Error, Information, and Debug. The options you select determine what messages appear in the <a href="#">Error Logging View</a> .

## Messages

The Messages Preference settings display the default location of the application log file and what type of error logging messages are displayed.

Preference	Description
Log File Location	Displays the location of the log file. This location cannot be edited.
Error Logging Options	You can select to display the following message types: Debug, Error, Fatal, Information, Trace, and Warning. The options you select determine what messages appear in the <a href="#">Error Logging View</a> .

## Model view

There are two different preferences you can set for the Model View:

Preference	Description
Automatically Expand when Clicking Expand All Button	If you have large models and click the Expand All icon in the Model View, you will get a dialog warning you that this action may take an extended length of time. Prompt: The warning dialog will always appear. Always: The Expand All action happens without the warning dialog.
Display Tooltips	When "On" is selected, a descriptive text box appears when the cursor is placed on an icon or node in the Model View tree.
Group Objects by Type	Objects within a model are displayed in the tree grouped by type (for example, a Task node will contain all of the tasks within the model).
Select presentation nodes when using the Find In Model View Feature	If this preference is set, both the presentation element node (designated by a small arrow placed on the element  ) as well as the element node are highlighted in the Model View tree.

## Naming

Select this option if you want to include the source and target in the relationship names.

If you select this option the relationship names are displayed as follows in the Model View tree and diagram:

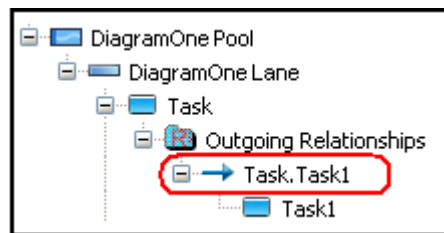

If this option is not selected, the target/source relationship names are displayed as follows in the Model View tree and diagram:

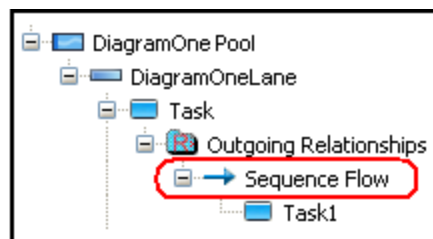



## Property views

You can set a preference for opening [Property Views](#) for each created object. When this preference is selected, each time you create an object, either in the Model View or from the palette, the associated Property View is opened as well.

**NOTE:** You can close all Property Views by selecting File > Close > All Property Views from the main menu or the Close All menu on the Property View toolbar.

Preference	Description
Open Property View on object creation	If you select this option, whenever you place a new object on the diagram window the property view pane displays so you can enter property values for the new object.

## Reporting

You have two options for the Web Report:

Preference	Description
Launch report upon completion	If you select this option, once you select the command to generate reports on all diagrams in an opened workspace, a web browser is launched showing the report.
Default report location	Click Browse to select the folder where you want your Web Reports stored. You can also create a new folder in the Browse For Folder dialog.

## Repository options

You have three options for the Repository:

Preferences	Description
Server Machine	Specify the URL or hostname of ER/Studio Repository.
Server Port	Specify the port ER/Studio BA uses to communicate with the repository server. The default is 54333.
Check out model when checking out diagram	Choose what action, if any, you want the system to perform with respect to the models in a diagram, when a diagram is checked out; <i>always</i> check out the models, <i>never</i> check out the models, or <i>prompt</i> the user to decide what to do each time a diagram is checked out.

## Workspaces/Models

The table below describes the preferences available for the Workspaces/Models node:

Detail	Description
Workspace Options	
Default workspace directory	Click the browse button to open the Browse For Folder dialog. You can change the existing default directory or create a new folder to be the default directory.
Entries in recently used workspace list	Set the number of previous workspaces you want to appear in the File > History menu. The default setting is 4.
Prompt for workspace when starting application	If this option is selected, the <a href="#">Welcome</a> dialog opens when you first start the application. It allows you to create a new workspace, open the last used workspace, import a compressed-format workspace, or open an existing workspace. If it is not selected, ER/Studio BA opens to the last used workspace.
Model Options	
Default Model Type	When you create a model, the default model type can be set so the preferred type always appears in the Model Type list box.



# Using ER/Studio Business Architect

The ER/Studio BA workflow enforces a hierarchical approach to help you manage large design projects. To use the application effectively, it is important that you understand the product's scope and the relationship between Workspaces, Projects, Models, Diagrams, and Diagram Elements (objects) before using the product. This section of Help gives you information on how to use the ER/Studio BA features listed below:

- [Workspaces and Projects](#)
- [Using Models](#)
- [Processes - Business Process Modeling](#)
- [Diagrams and Elements](#)
- [Reference Objects](#)
- [External Data Objects](#)
- [Drawing Shapes](#)

## Workspaces and projects

A [workspace](#) is a unit of storage used for any collection of data modeling projects, reference objects, and data source projects. In ER/Studio BA you can only open and work with one workspace at a time, but you can collect any number of projects in a single workspace.

A [project](#) is used to create a collection of user-created data models or subprojects. Data sources and reference objects also exist as their own projects within the workspace. A Project is a collection of items including models, diagrams, model elements, documents, business rules, etc. For example, a "Human Resources" project might contain a business process model describing the main functions of the Human Resources department, and a data model describing the data structures used by these processes, and business rules describing prescribed behavior of the organization. You can also create nested projects where a project is a parent of another project.

The graphic below shows both a Business Process Modeling workspace and project in the Model View tree.

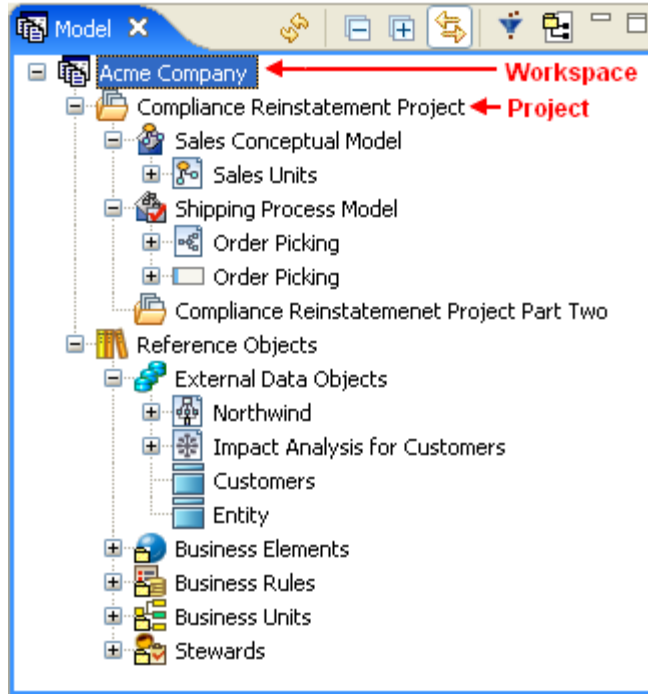

## Using workspaces

In the Model View tree, your workspace occupies the root node under which all projects and their associated elements appear in a hierarchical format. On creation, you can specify the name and location of your workspace and save it as an \*.exw file.

It is easy to create a workspace from the [Welcome](#) page that opens when you first start the application. Once you create a workspace you can insert a [project](#) or a [model](#). You can then [save](#), [open](#), [close](#), [rename](#), and [delete](#) it. You can also open a workspace in [read-only mode](#). You can open the [Property View](#) for the workspace.

## Using the Workspace dialog

When you first start ER/Studio BA the splash screen opens followed by the *Welcome to ER/Studio Business Architect* dialog. You have four options available:

Option	Description
Create a new workspace (with optional project, model, and diagram)	Opens the New Workspace dialog where you create a new workspace, project, model, and diagram. For more information, see <a href="#">Creating a New Workspace</a> .
Express create	You can quickly create a workspace, project, model, and diagram. Select the type of model and enter a name, which is used for the workspace, project, model and diagram that are created. For more information, see <a href="#">Using Express Create</a> .

Option	Description
Import a compressed workspace	You can import and open an existing workspace that you have <a href="#">exported</a> and stored as a compressed file. For more information, see <a href="#">Importing a Compressed Workspace</a> .
Open My Last Used Workspace	Opens the last workspace you worked on. This is the default setting if a previous workspace exists.
Open an Existing Workspace	Click Browse to open the Browse for a workspace file dialog. The default path is x:/My Documents/ EStudioBusinessArchitect/
Get a workspace from the Repository	When selected and OK has been clicked, the ER/ Studio Repository log in dialog appears where you can log in and then copy a workspace from the ER/ Studio Repository to your local desktop.
Always use last workspace on startup	If you select this option, each time you open ER/ Studio BA, the last workspace you worked on automatically opens.

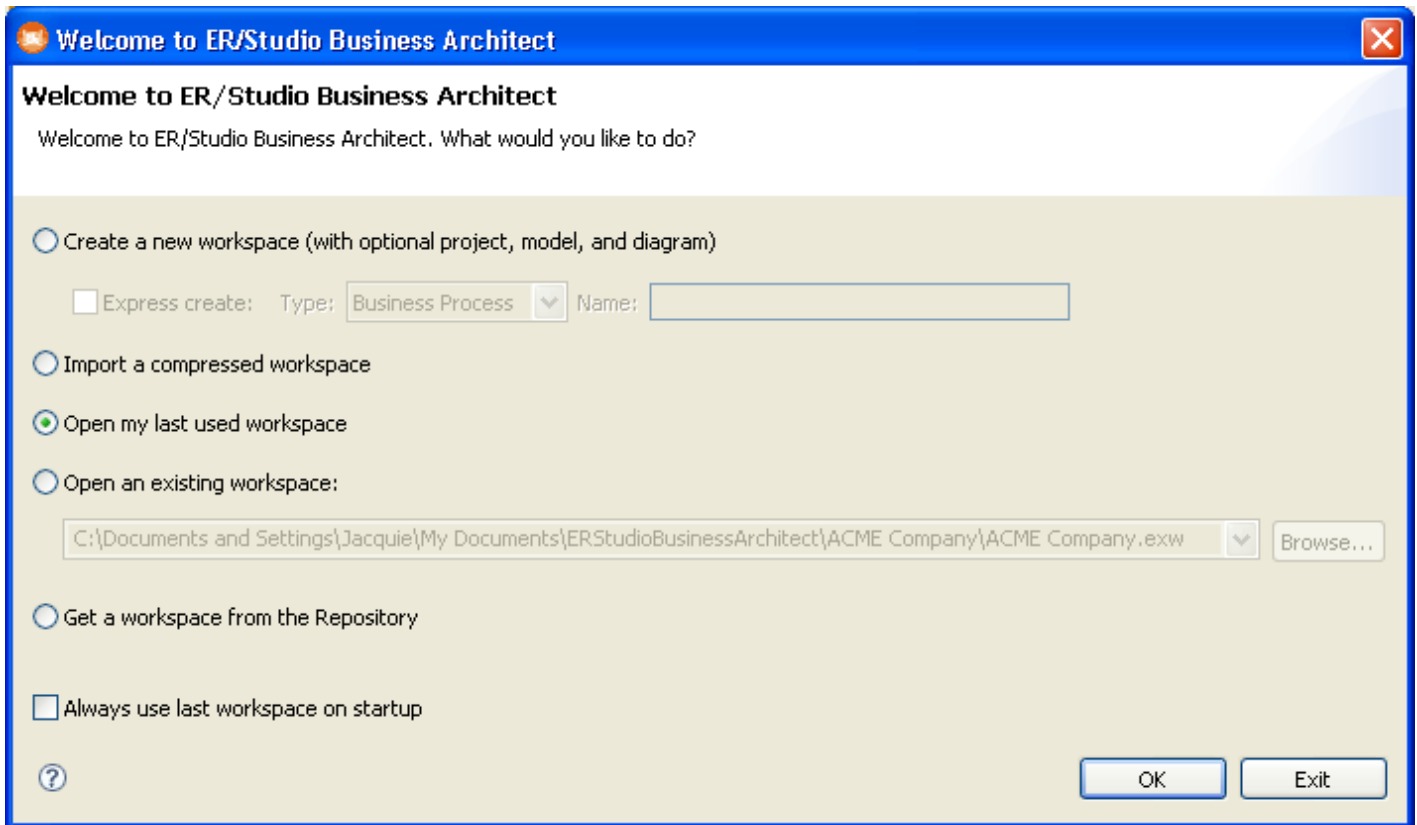

## Creating a new workspace

You can create a Workspace, and if desired, a Project, a Model, and a Diagram as well using the *Create a New Workspace* dialog. The file extension of a workspace is *.exw*.

1. On the File menu, select *New > Workspace*. The *New Workspace* dialog opens.

**NOTE:** When creating a new workspace, if an existing workspace is open, you get a *Save Workspace* dialog asking if you want to save the current workspace. Click *Yes* and it is closed. When the previous workspace is closed, all projects, models, and diagrams associated with the workspace are also saved and closed.

2. Enter the workspace name in the first text box.

The default path for workspaces is *... \My Documents\IDERA\ERStudioDataArchitect*. You can click the drop-down arrow in this text box to display a list of last used locations.

3. If you want to change the path, click *Browse* to open the *Browse For Folder* dialog and select another folder.

**NOTE:** You can also create a new folder by clicking *Make New Folder*.

4. If you want to create an associated project at this time, click *Create a project* within this workspace. You can now enter the name of that project in the *Project Name* text box.

Next, you can create a model and associate it with either the project or the workspace. A model is a specific collection of elements related to a modeling notation such as Business Process Modeling Notation or Conceptual Modeling.

5. Click *Create a model within this...* and then select either *Project* or *Workspace* from the drop-down list.

6. Enter the name of your model in the *Model Name* text box.

7. Select either *Business Process* or *Conceptual* from the *Model type* drop-down list.

8. If you are creating a Business Process model, you can select *On* in the *Validate against BPMN specification* box, to enable the validation option.

The validation checks compliance to the Business Process Modeling Notation specifications. For example, if validation is enabled and you draw a message flow from a start event to a task, you get a dialog stating that this is an invalid relationship. If validation is set to *Off*, it is drawn without notification.

**NOTE:** When you select *On* the following icon is displayed  next to the model node in the tree. If you select *Off*, a different icon  is displayed.

9. To create a diagram associated with the model click *Create a diagram within this model* and enter the name of your diagram in the *Diagram Name* text box.

**NOTE:** If you are creating a Business Process model, notice that the diagram name, the *Name of pool with invisible boundary* and *First lane name* text boxes are populated with the same name as the Model name. You can then rename the diagram, the pool, and the lane if desired. If you are creating a Conceptual model, these fields are not available.

In the Business Process Modeling Notation Specification, all business process diagrams must contain at least one pool and each pool is a container for one process. In ER/Studio BA, when you create a diagram, a pool and lane with an invisible boundary are automatically created.

10. Click *OK*. ER/Studio BA creates the workspace (with the file extension of *.exw*), project, model, and diagram and adds them to the Model View tree.

## Related Topics:

- [Creating a Project](#)
- [Upgrading Workspaces](#)

## Upgrading workspaces

If you have upgraded ER/Studio BA to a newer version your workspace must be upgraded before it can be used. The first time you open an existing workspace, or if you are importing a compressed workspace, the Workspace Upgrade dialog opens. This process updates the version number in the workspace, project(s), model(s), and data source files. It also [updates](#) business attribute optionality and connection label justification.

**CAUTION:** When upgrading workspaces that have elements created by importing an ER/Studio model, if the ER/Studio model is imported again in version 1.6, new elements are added instead of updating the existing ones.

1. Click **Details** to view a list of what the upgrade process includes. The upgrades include the following:
  - o Business Process Modeling process information
  - o Shape transparency
  - o Mandatory Property of conceptual modeling relationships
  - o Unique identifier options for conceptual model business attributes
  - o Bound element properties for conceptual model business attributes
  - o Enforcement options for business elements.
2. The hierarchy that appears in the list box includes the workspace and all projects and models. It also includes any reference and external data objects. Clear the check box of any items you want excluded from the upgrade.

**NOTE:** Excluded items are removed from the workspace and are automatically upgraded if they are inserted back into the workspace.

3. You have the option to back up your workspace before performing the upgrade. Browse to the location where you want to store your backup. The workspace name is appended with "backup" and has a file extension of .exz.

**NOTE:** If the upgrade fails you can [import](#) the backup file.

4. Click **OK** and a progress dialog opens telling you the workspace is being upgraded. A dialog opens telling you that the upgrade was successful.
5. Click **Details** and a list of all upgraded files open. You can print or save these details.
6. Click **OK** to close this dialog and the upgraded workspace opens in ER/Studio BA.

**CAUTION:** Workspaces created in ER/Studio BA's beta versions are not upgraded.

## Updating business elements and business attributes

The upgrade processes business attributes first and then business elements, based on rules below.

- For business elements, if the enforce/propagate properties are cleared in the 1.0/1.1 version, the enforcement options should be cleared after upgrade. If the enforce/propagate properties are selected in the 1.0/1.1 version, the enforcement options should be selected after upgrade.

- For business attributes:
  - If the “enforce name” property is selected on the original business element, a comparison will be done on each business attribute bound to the business element. If the attribute name matches the business element name, the override property is not set. If the names don’t match, the override property is set.
  - If the “propagate data type” property is selected on the original business element, a comparison will be done on each business attribute bound to the business element. If the data type matches the business element data type, the override property is not set. If the data types don’t match, the override property is set.
  - If the “propagate description” property is selected on the original business element, a comparison will be done on each business attribute bound to the business element. If the attribute description matches the business element description, the override property is not set. If the descriptions don’t match, the override property is set.
  - If the “propagate notes” property is selected on the original business element, a comparison will be done on each business attribute bound to the business element. If the attribute’s notes match the business element’s notes, the override property is not set. If the notes don’t match, the override property is set.

### Exporting a workspace

You can export your workspaces in a compressed format. You can then import that compressed workspace into another ER/Studio BA application on another computer. The file extension for this compressed file is .exz.

1. Open the workspace you want to export in the Model View tree.
2. Select File > Export > Workspace from the main menu and the Export dialog opens.

OR

Right-click the workspace node in the Model View tree and select  Export....

**NOTE:** If your workspace has been modified and has not been saved, you will get a warning dialog asking you to save it.

3. Select the location where you want to save the compressed file and enter a new file name if desired.

**NOTE:** You will get a warning if the compressed files already exist in that location.

4. Click Save and the file is saved to your chosen location. The workspace name is appended with “\_backup” and has a file extension of .exz.

### Importing a compressed workspace

You can import and open a compressed workspace in ER/Studio BA.

1. In the Welcome to ER/Studio BA dialog (which is available when you first start the application), select Import a Compressed Workspace.

OR

From the main menu select File > Import > Workspace.... The Import a Compressed Workspace dialog opens.

2. Enter or browse to the location where you stored your compressed workspace.

**NOTE:** The file extension for the compressed workspace is .exz.



3. Enter or browse to the location where you want to extract the selected workspace.  
**CAUTION:** You will get a warning in the dialog if you attempt to extract a compressed workspace file to a folder that already contains one or more files included in the compressed file.
4. Click OK and compressed workspace is opened in the Model View tree.  
**NOTE:** If you are importing a workspace into a newer version of ER/Studio BA, a [Workspace Upgrade](#) dialog opens.

### Using Express Create

When you first open ER/Studio BA a *Welcome to ER/Studio Business Architect* dialog opens. Instead of using the Create a New Workspace option, you can use the Express Create which streamlines the creation process by creating a workspace, project, model, and diagram all named the same.

**NOTE:** The Express Create option is only available in the Welcome to ER/Studio Business Architect dialog.

1. Select the Express Create option in the Welcome dialog.
2. Select the Type from the drop-down list box. Your choices are Business Process and Conceptual.
3. Enter the name you want to use for your new workspace, project, model, and diagram.
4. When you click OK the created workspace, project, model and diagram appear in the Model View tree. The diagram is also opened in the Diagram View as a tabbed view. The palette associated with the model (i.e., either Business Process or Conceptual) is available in the Palette view.

### Saving a workspace

A workspace is saved under the following conditions:

- When a workspace is created, it is automatically saved.
- When you close a workspace or exit the application, you are prompted to save your current workspace.
- When you open an existing workspace or create a new workspace, if another workspace is open, you are prompted to save that workspace.

When you make additions or changes in a workspace, you can save your workspace by: Clicking Save () on the main toolbar.

OR

Right-clicking the workspace name in the Model View tree and selecting Save Workspace.

OR

From the main menu, select File > Save.

## Opening a workspace

Only one workspace can be opened at a time in the Model View tree.

1. Choose File > Open Workspace.
2. Press Ctrl +O.
3. Right-click in the Model View and select Open Workspace. The Open dialog appears listing all available workspaces in the default location.
4. Expand the Workspace folder you want to open and double-click the file with the extension .exw. This is the file extension for all workspaces.

**NOTE:** If you have another workspace open, you are prompted to save the current workspace.

When you click Yes, that workspace is saved and the newly selected workspace is opened in the Model View tree.

## Closing a workspace

1. Choose File > Close>Workspace.
2. Right-click the workspace node in the Model View and select Close.

**NOTE:** If you have made additions or changes to your workspace you are prompted to save your current workspace. Click Yes and the workspace and all the project, model, and diagram data is saved and closed.

## Renaming a workspace

1. Right-click the workspace node in the Model View tree and select Rename Workspace.

**NOTE:** If your workspace is unsaved a Save Workspace dialog opens telling you that you must save your workspace before it can be renamed.

2. In the Rename Workspace dialog, enter the new name in the text box and click OK.

## Deleting a workspace

When you create a new workspace, a folder with the workspace name is created in your default location, for example ...My Documents\ERStudioBusinessArchitect\*workspace name*.

To delete a workspace:

1. Right-click the Workspace name in the Model View tree and select Delete.
2. In the Confirm Workspace Delete dialog you have three choices.

No, I do not want to delete the workspace.	The delete action is canceled and no action is taken.
Yes, and also delete the associated files under x:\.Documents and Settings\...	This option lists the entire path where the workspace files are stored. When you choose this option, the workspace is deleted from the Model View tree and the folder containing the workspace information is also deleted.
Yes, but do not delete the associated files.	The reference to the workspace in the Model View tree is removed but the workspace folder still remains in the directory.

3. Select the option you want and click OK.

**NOTE:** If you select the third option, reopen the workspace by going to the location where the workspace is stored, for example ...My Documents\ERStudioBusinessArchitect\*workspace name*, and double-click the name.

## Using read-only workspaces

A workspace will be opened as read-only under the following conditions

- Open the same workspace on the same computer
- Open the same workspace on a network

When you open a workspace that is already open, you will be informed that the workspace is in use but that it can be opened as read-only. You can then choose to open the workspace as read only or cancel the operation..

When you open workspace as read-only, the workspace name is shown in the title bar with a read-only indicator. You can view the models in the workspace, generate reports, but can't make any changes to the workspace data or diagrams. All import mechanisms are also disabled.

**NOTE:** A temporary marker file is used to track the open status of a workspace (~MyWorkspace.etwtemp), created in the workspace's folder on the file system.

The following actions are NOT allowed in a read-only workspace:

- Import of Visio, CSV, or ER/Studio
- Deleting from menus, diagrams, model views, or property views
- Create actions from menus, diagrams, model view, property views
- Cut/copy and paste
- Accessing Property Views
- Diagram creation
- Editing a Diagram (moves, deletes, editing, show/hide)
- Dropping elements from toolbars or palettes
- Drag/drop in model view within metadata or diagram nodes
- No drag/drop from model view to diagram
- Any save actions
- Setting of properties from right-click menus

The following actions are allowed in a read-only workspace:

- Export
- Generation of a new web report
- Rename - Project, Model, Diagram, Independent Sub-process, Invisible Pool.
- Insert Project/Model, Insert Model.
- Creating Impact Analysis Diagram.





## Using projects

A Project is a collection of items including models, documents, business rules, etc. For example, a “Human Resources” project might contain a business process model describing the main functions of the Human Resources department, and a data model describing the data structures used by these processes, and business rules describing prescribed behavior of the organization. The file extension of a project is .exp. You can:

- [Creating a Project](#)
- [Inserting a Project](#)
- [Reparenting a Project](#)
- [Renaming a Project](#)
- [Closing a Project](#)
- [Saving a Project](#)
- [Deleting a Project](#)

**NOTE:** You can have multiple Projects open simultaneously. You can then easily switch back and forth between them.

Right-click a Project in the Model View tree to gain access to additional functions:

Command	Icons	Description
<a href="#">Links</a>		This command opens the Create Link wizard which allows you to create links between elements.
<a href="#">Usages</a>		This command opens the Create Usage wizard which allows you to create usage connections between elements.
Impact Analysis		You have two commands available from the pull-right menu: You can generate an <a href="#">Impact Analysis Diagram</a> which graphically displays all the associated relationships and elements. You can also show the <a href="#">Impact Analysis Report</a> .
Refresh		Updates the currently displayed information in the Model View with new data or changes.
Properties		Opens the <a href="#">Property View</a> for the selected element.

### Creating a project

When you create a workspace, you can create a new project at that time in the [New Workspace](#) dialog. But you can also create other new projects in that workspace to store your models and diagrams using the New Project dialog.

1. On the File menu, select New > Project.  
OR  
In the Model View tree right-click the workspace and select New > Project. The New Project dialog opens.
2. In the Project name box, type the name of the new project.
3. You can enter a description of the new project in the Description text box. Press Enter to add a CRLF in the text box.

**NOTE:** If you press Ctrl+Enter the New Project dialog closes and the new project name appears in the Model View tree.

4. You can then select where to create the project: in the existing workspace or nested in the existing project.
  5. Click OK. The project is created and the dialog box closes.
- NOTE:** The default storage directory for the new project is set when you create the workspace.

### Inserting a project

If you have deleted a project or model but did not [delete the associated files](#) you can select this command to “restore” the deleted project or model. You can:

- insert a model in a model
- insert a model in a project
- insert a project in a workspace
- insert a data source project under External Data Objects node.

The following actions are NOT allowed when inserting projects and models:

- insert a project from another workspace
- insert a project under a model
- insert a reference object project under a workspace, project, or model
- insert a data source project under a workspace, project, or model
- insert a project or model under the External Data Objects node
- insert a reference project under the External Data Objects node

**CAUTION:** The undo/redo function is not available for the insert project command.

To insert a project:

1. Right-click the Workspace node in the Model View tree and select Insert Project/Model.
2. In the Insert Project or Model dialog open the folder that is labeled with the project’s name that you want to restore.

**CAUTION:** If you attempt to insert a project into another workspace you will get a warning dialog. A project can only be inserted into the workspace it was created in.

3. Select the file labeled `meta-model.exp`, click Open and the selected project is placed in the Model View tree.

### Reparenting a project

You can reparent a project within a workspace by dragging and dropping the project from one location to another. Basically you will be removing the project from the current workspace location and immediately reinserting the project into the workspace at another location. When you reparent the project, all associated files including models, diagrams, and elements are also reparented.

**CAUTION:** It is recommended you [back up](#) your workspace before doing a reparenting action.

The following rules apply to the reparenting action. If any of the error conditions listed below occurs, you will get a dialog warning you that the reparenting is not valid and will not be allowed.

- Projects can be reparented to workspace.
- A project will be allowed to be reparented to another project, but not to one of its own child projects.
- A project will not be allowed to be reparented to the following: (1) Reference Object project; (2) External Data Object project; (3) a data source; or (4) a model.
- A model will be allowed to be reparented to a project.
- A model will be allowed to be reparented to a model of its same nature (i.e., Conceptual or Business Process) as long as it isn't one of its own child models.
- Models can be reparented to workspace.
- You cannot reparent a Reference Object project or an External Data Object project.
- A data source:
  - will be allowed to be reparented to another data source as long as it isn't one of its own children.
  - will be allowed to be reparented to the External Data Objects project.
  - will not be allowed to be reparented to the Reference Object project.
  - will not be allowed to be reparented to a project or model.

To Reparent a Project:

1. In the Model View, select the project you want to reparent and drag it to its new location.

**NOTE:** When dragging the node, the destination node must be highlighted as illustrated in the following screen shot.

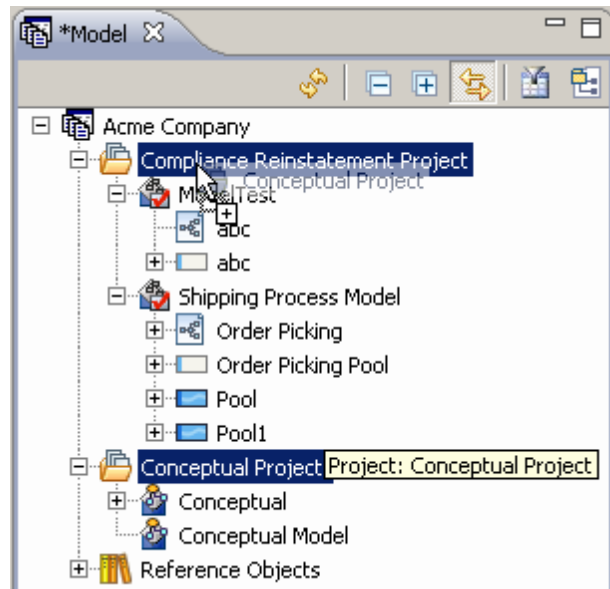

**NOTE:** If you have not saved your workspace you will get a warning dialog telling you that you must save the workspace and all associated diagrams must be closed. If you click Yes the workspace is saved, all associated diagrams are closed, and the project is reparented.



2. Release the node and the project and all associated files are reparented to its new location.

### Renaming a project

You can rename a project by using the Rename Project command. When you rename a project you are changing the name of the project and the associated project's folder on the file system.

In the Model View tree, select the project node you want to rename.

1. Right-click the node and select Rename Project.
2. Enter the new name in the text box and press Enter. The project's name changes.

### Closing a project

1. Right-click the project node in the Model View and select Close.

**NOTE:** If you have made additions or changes to your project you are prompted to save it. Click Yes and the project, model, and diagram data are saved and closed.

### Saving a project

A project is saved under the following conditions:

- When a project is created, it is automatically saved.
- When you close a project, you are prompted to save it.

When you make additions or changes to a model or diagram in a project, you can save your project by:

1. Clicking Save (  ) on the main toolbar.
2. Right-clicking the project name in the Model View tree and selecting Save Project.
3. On the main menu, choose File > Save.

### Deleting a project

1. Right-click the Project name in the Model View tree and select Delete.
2. In the Confirm Project Delete dialog you have three choices:

No, I do not want to delete the project.	The delete action is canceled and no action is taken.
Yes, and also delete the associated files under x:\.Documents and Settings\....	This option lists the entire path where the Project files are stored. When you choose this option, the project is deleted from the Model View tree and the folder containing the project information is also deleted.
Yes, but do not delete the associated files.	The reference to the project in the Model View tree is removed but the project folder still remains in the directory.

3. Select the option you want and click OK.

**CAUTION:** The undo/redo function is not available for the remove command, which is the third option in the Confirm Project Delete dialog.



## Using models

A model is a specific collection of elements/objects related to a modeling notation (BPMN, Conceptual, etc.). For example, the Human Resources BPMN model would contain those objects associated with the business processes of HR: tasks, swimlanes, gateways, etc. A model is where the object “lives”. i.e., objects are stored within a model, but can be visualized in other formats such as a visual diagram, grid editor, etc. In Business Process Modeling you can choose whether to create a model in “Validation” mode, which enforces the rules of the specified notation, or with validation off, which allows you to use the visual objects without being constrained by the rules of the notation. Nested models are allowed. The file extension of a model is .exm.

When you [create a workspace](#) or project in ER/Studio BA you are given the opportunity to create a new model. You can have “nested” models with a model. These nested models can also contain diagrams as shown in the following graphic.

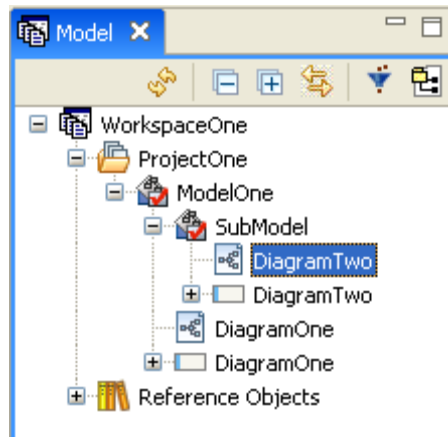

Elements within a model can be displayed two different ways in the Model View tree:

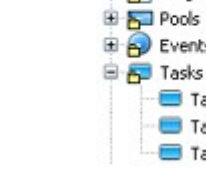
Command	Description	Example
<a href="#">Grouping by Object Type</a>	When you click the Group by Object type icon (  ), elements are sorted by type, for example, a Task node contains all of the tasks within the model. Under each node the items are sorted alphabetically, unless there is a sequence associated with an object (lanes, for example).	

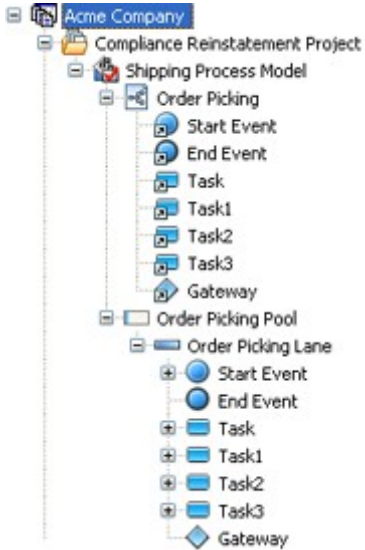



Command	Description	Example
<a href="#">Model View Hierarchy</a>	This is a hierarchal representation of all elements in a model, in a diagram node, and in the model node.	



## Working with models

You can create a new Model at the time you [create a workspace](#) or by using the [menu command](#). Once you create it, you can do the following to a model:

- [Open/close](#)
- [Save](#)
- [Rename](#)
- [Reparent](#)
- [Insert](#)
- [Delete](#)



Right-click a model node in the Model View tree to gain access to the following additional functions:



Command	Icon	Description
<a href="#">Links</a>		This command opens the Create Link wizard which allows you to create links between elements.
<a href="#">Usages</a>		This command opens the Create Usage wizard which allows you to create usage connections between elements.
<a href="#">Grid Editor</a>		This is a table-like editor which is an alternative to the Model View. Content in the Grid Editor can be printed or exported as a report.
Impact Analysis		You have two commands available from the pull-right menu: You can generate an <a href="#">Impact Analysis Diagram</a> which graphically displays all the associated relationships and elements. You can also show the <a href="#">Impact Analysis Report</a> .

Command	Icon	Description
Refresh		Updates the currently displayed information with new data or changes.
Properties		Opens the <a href="#">Property View</a> for the selected model.

### Creating a model using the Menu command

1. On the File menu, select New > Model.  
OR  
In the Model View tree, right-click the workspace and select New > Model to open the New Model dialog.  
**NOTE:** You can also create a new model by right-clicking the project node or the model node in the Model View tree.
2. Enter the model name in the Model Name text box.
3. In the Model Type drop-down list, select the type of model you want to create. You have the following options:

Model Icon	Model Type	Description
	<a href="#">Conceptual Modeling</a>	Conceptual modeling is used by enterprise architects, business users, and data architects to model information about the business as it relates to data, data flow, process, or information assets.
	<a href="#">Business Process Modeling</a>	Uses the Business Process Modeling Notation (BPMN) specification to graphically express business processes.

4. If you are creating a Business Process model, select On in the Validate against BPMN specification box to enable the validation option. If you are creating a Conceptual Model, this option is unavailable.  
  
The validation checks compliance to the Business Process Modeling Notation specifications. For example, if validation is enabled and you draw a message flow from a start event to a task, you get a dialog stating that this is an invalid relationship. If validation is off, it is drawn without notification. When you select On, the following icon is displayed  next to the model node in the tree. If you select Off, a different icon  is displayed.  
**NOTE:** The default [preference](#) for validation can be set. When creating a new model, the New Model Wizard displays the preference set, which you can change.
5. You can enter a description of the new model in the Description text box. Press Enter to add a CRLF in the text box.  
**NOTE:** If you press Ctrl+Enter the New Model dialog closes and the new model name appears in the Model View tree.
6. Select where to create the model: either in the workspace, or in a project. You can also nest a model within a model.  
**NOTE:** The default storage directory for the new model is set when you create the workspace.

7. To create a diagram associated with the model click Create a diagram within this model and enter the name of your diagram in the Diagram Name text box.

**NOTE:** If you are creating a Business Process model, notice that as you enter the diagram name, the Name of pool with invisible boundary and First lane name text boxes are populated with the same name. You can then rename both the pool and the lane if desired. If you are creating a Conceptual model, these fields are not available.

In the Business Process Modeling Notation Specification, all business process diagrams must contain at least one pool and each pool is a container for one process. In ER/Studio BA, when you create a diagram, a pool and lane with an invisible boundary are automatically created.

8. Click OK. The new model is created and placed in the location you selected.

### Saving a model

A model is saved under the following conditions:

- When a model is created, it is automatically saved.

When you make additions or changes in a model, you can save your model by:

- Clicking Save () on the main toolbar.

OR

- Right-clicking the model name in the Model View tree and selecting Save Model.

### Renaming a model

You can rename a model in the Model View tree.

1. In the Model View tree, right-click the model node you want to rename and select Rename Model.
2. In the Rename Model dialog enter the new name in the text box and click OK. The model is renamed in the Model View tree and in the file folder.

### Reparenting a model

You can reparent a model within a workspace by dragging and dropping the model from one location to another. Basically you will be removing the model from the current workspace location and immediately reinserting the model into the workspace at another location. When you reparent the model, all associated files including diagrams and elements are also reparented.

**CAUTION:** It is recommended you [back up](#) your workspace before doing a reparenting action.

The following rules apply to the reparenting action. If any of the error conditions listed below occurs, you will get a dialog warning you that the reparenting is not valid and will not be allowed. Note that these rules apply to both projects and models.

- Projects can be reparented to workspace.
- A project will be allowed to be reparented to another project, but not to one of its own child projects.
- A project will not be allowed to be reparented to the following: (1) Reference Object project; (2) External Data Object project; (3) a data source; or (4) a model.

- A model will be allowed to be reparented to a project.
- A model will be allowed to be reparented to a model of its same nature (i.e., Conceptual or Business Process) as long as it isn't one of its own child models.
- Models can be reparented to workspace.
- You cannot reparent a Reference Object project or an External Data Object project.
- A data source:
  - will be allowed to be reparented to another data source as long as it isn't one of its own children.
  - will be allowed to be reparented to the External Data Objects project.
  - will not be allowed to be reparented to the Reference Object project.
  - will not be allowed to be reparented to a project or model.

To Reparent a Model:

1. In the Model View, select the model you want to reparent and drag it to its new location.

**NOTE:** When dragging the node, the destination node must be highlighted as illustrated in the following screen shot.

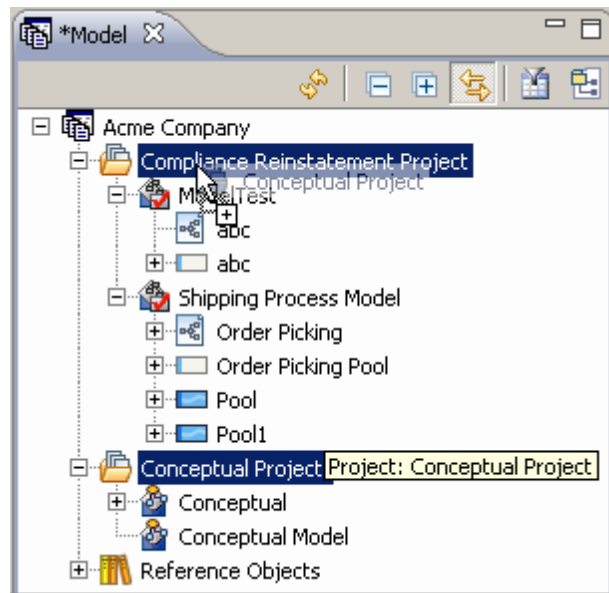

**NOTE:** If you have not saved your workspace you will get a warning dialog telling you that you must save the workspace and all associated diagrams must be closed. If you click Yes the workspace is saved, all associated diagrams are closed, and the model is reparented.

2. Release the node and the model and all associated files are reparented to its new location.

### Deleting a model

When you delete a model, you are presented with three different options in the *Confirm Model Delete* dialog.

1. In the Model View tree, right-click the model node you want to delete and select Delete.
2. In the Confirm Model Delete dialog you have three choices:

No, I do not want to delete the model.	The delete action is canceled and no action is taken.
Yes, and also delete the associated files under x:\.Documents and Settings\...	This option lists the entire path where the model files are stored. When you choose this option, the model is deleted from the Model View tree and the folder containing the model information is also deleted.
Yes, but do not delete the associated files.	The reference to the model in the Model View tree is removed but the model folder still remains in the directory.

3. Select the option you want and click OK.

### Opening and closing a model

When you first open a workspace the model is closed. You can open the model and all associated diagrams and elements:

1. Right-click the model in the Model View tree.
2. Click Open. The Model View tree expands displaying all associated diagrams and diagram elements.

**NOTE:** You can also open the model by clicking the plus icon (+) next to the model node.

You can close the model as well. This action collapses the model node in the Model View tree.

3. Right-click the model in the Model View tree.
4. Click Close. The Model node of the Model View tree collapses hiding all associated diagrams and diagram elements.

### Inserting a model

If you have deleted a model but did not [delete the associated files](#), you can select this command to “restore” the deleted model.

1. Right-click the Model node in the Model View tree and select Insert Project/Model.
2. In the Insert Model dialog open the folder that is labeled with the model’s name that you want to restore.
3. Select the file labeled `meta-model.edsp`, click Open and the selected model is placed in the Model View tree.

## Processes – Business Process modeling

When working in ER/Studio BA, you have two different types of models, Conceptual and Business Process. When working with Business Process models, you work with Processes. This section discusses how processes are used when working with Business Process models.

A Process is a collection of flow objects connected by flows that is executed in a sequence (usually depicted on a diagram). In ER/Studio BA, all processes are contained by a pool. A pool contains only one process, but you can have multiple pools in a diagram which can then collaborate via messages.

You can set a [preference](#) to display elements in a diagram or pool under the Process node (  ) in the Model View. If this option is not selected, all elements are displayed under the Pool node.

In the Business Process Modeling Notation Specification, all Business Process Diagrams must contain at least one pool. In ER/Studio BA, when you [Diagram](#), a pool and lane with an invisible boundary are created as well. In ER/Studio BA, when you place an object in the diagram, that object is automatically placed in the pool.

Initially when you create the diagram, the pool and lane are given a default name. You can rename both the created pool and its associated lane.

In the following example, the diagram contains a pool with an invisible boundary (named Order Picking Pool) and is indicated by the  icon in the Model View tree. The lane, named Order Picking Lane, is "owned" by the pool. The event is owned by the process, but since the process is hidden, it appears under the pool.

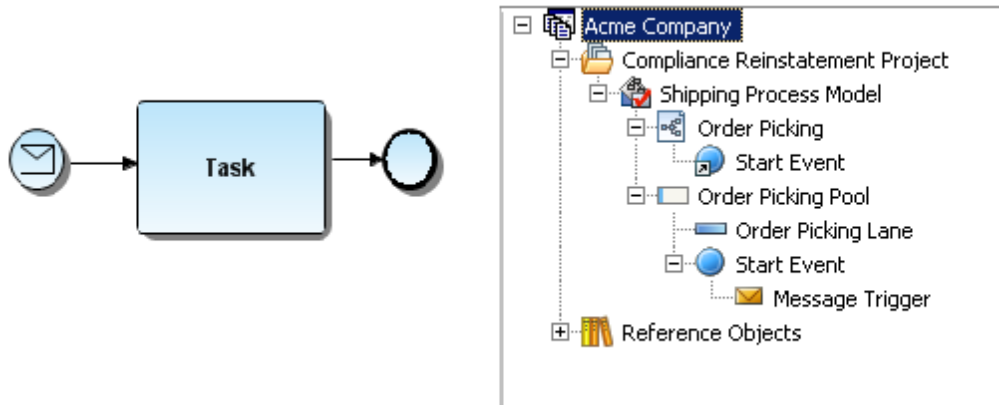

- When you place an element, for example a Start Event, that start event is shown as a presentation element under the Diagram node (this is indicated by an arrow symbol placed on the icon ).

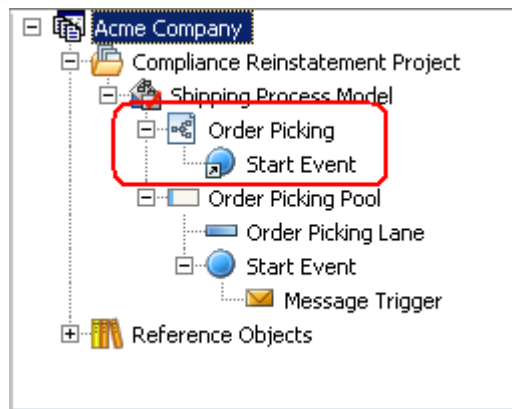

In the following example, the model contains one visible pool/lane and one invisible pool/lane. The Model View tree displays the elements under the pool. However, in the diagram node, the presentation elements are displayed under the lane node to show their location within the lanes depicted on the diagram.

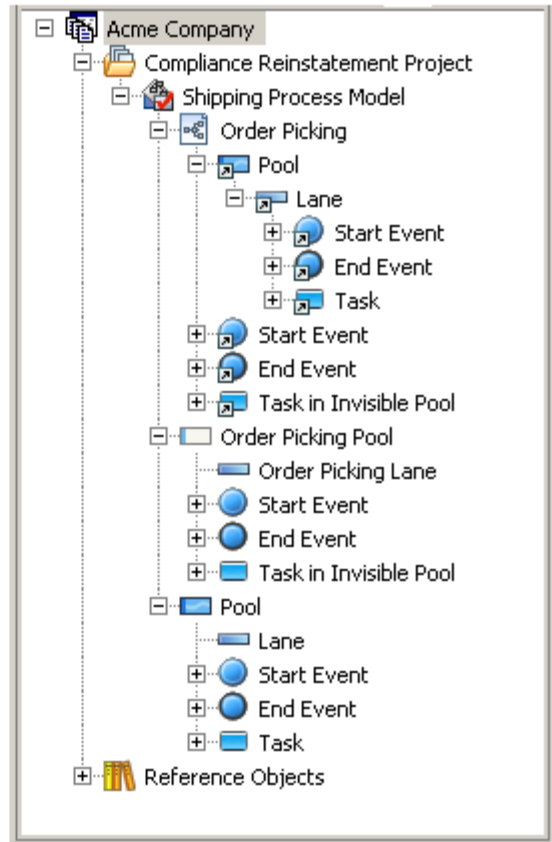
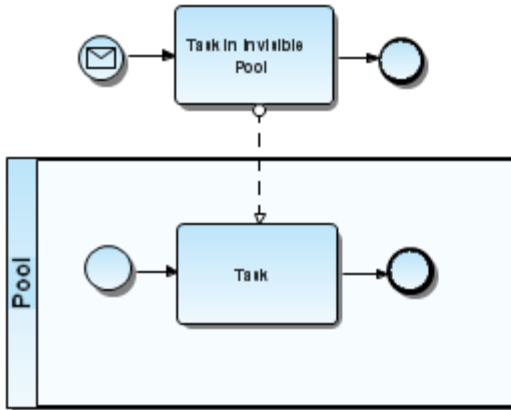

- If you select the preference to show process in the application the elements in a pool are displayed under the Process node.

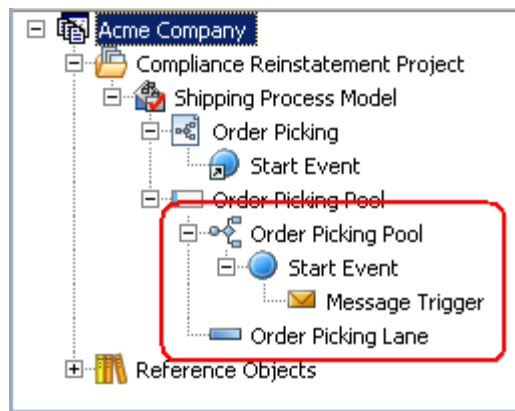



## Diagrams and elements

This section outlines how to work with diagrams and diagram elements and covers the following topics:

- [Using diagrams](#)
- [Using diagram elements](#)

### Using diagrams

In ER/Studio BA, you can model two different types of diagrams: Business Process and Conceptual.

#### Business Process diagrams

A Business Process Diagram (BPD) uses a flowcharting technique which is tailored for creating graphical models of business process operations. A Business Process Model is a network of graphical elements, which track the flow of activities and their order of performance.

A BPD is made up of a set of graphical elements that enable the easy development of simple diagrams. The elements utilize shapes that are familiar to most modelers. For example, activities are rectangles and decisions are diamonds. The end result is a mechanism used for creating business process models which are able to handle complex business processes.

The graphical aspects of the notation are separated into specific categories. This provides a small set of notation categories so that the reader of a BPD can easily recognize the basic types of elements and understand the diagram. Within the basic categories of elements, additional variation and information can be added to support the requirements for complexity without dramatically changing the basic look-and-feel of the diagram.

#### Conceptual diagrams

Conceptual modeling is used by enterprise architects, business users, and data architects to model information about the business as it relates to mostly to data. However it could include other things like data flow, process, or information assets. The conceptual model is used to drill down into more detail which would be Process models and Logical/Physical data models. It simplifies the organization of hundreds if not thousands of physical objects. It is powerful enough to link to further technical (or physical) detail, but simple enough to communicate to non-technical users.

#### Diagram Basics

- The Diagram View contains visual displays of elements.
- The Model View tree contains element nodes which are separate definitional metadata for those elements. Therefore, you can create an element without needing a graphical representation of it on the diagram.
- Elements can be reused or referenced in multiple models, regardless of model type, i.e. a database element from a data model can be reused/referenced in a business process model.
- The file extension of a diagram .exd.

The following sections discuss creating and working with diagrams, editing diagrams, and using the zoom features. Related Topics:

- [Using Diagram Elements.](#)

## Working with diagrams

You can create two different types of diagrams: Business Process Diagrams and Conceptual Diagrams. In the Business Process Diagram, you can create graphic business process models based on the Business Process Modeling Notation. When you create a business process diagram, a pool and a lane with an invisible boundary are automatically created. In the Business Process Modeling Notation Specification, all business process diagrams must contain at least one pool and each pool is a container for one process.

In the Conceptual Diagram, you model information about a business as it relates to data, data flow, process, or information assets.

When you create a diagram, the application opens a new diagram view, which you can use to arrange the elements and links of your diagram.

You have the following actions available with diagrams: [create](#), [open and close](#), [export](#), [delete Business Process diagrams](#), [delete Conceptual Model diagrams](#), [rename](#), and [print](#). You can also have a [Diagram Usage](#) dialog that helps you locate an element on multiple diagrams.

Right-click the newly created diagram to gain access to additional functions:

Command	Description
<a href="#">Grid Editor</a>	This is a table-like editor which is an alternative to the Model View. Content in the Grid Editor can be printed or exported as a report.
Refresh	Updates the currently displayed information with new data or changes.
Properties	Opens the <a href="#">Property View</a> for the selected element.

## Creating a diagram

You can create a new diagram at the time you [create a workspace](#) or by using the menu command.

1. On the File menu, select New > Diagram. The pull-right menu displays the type of diagram to be created. For example if you are creating a new diagram in a Conceptual Model, only Conceptual is available from the pull-right menu.  
OR  
Right-click the model name in the Model View tree and select New > Diagram.
2. In the New Diagram dialog, enter the diagram name in the Diagram name text box.
3. You can enter a description of the new diagram in the Description text box. Press Enter to add a CRLF in the text box.  
**NOTE:** If you press Ctrl+Enter the New Diagram dialog closes and the new diagram name appears in the Model View tree.
4. You can then select which model to place the diagram in from the models appearing in the list box.  
**NOTE:** If you are creating a Business Process diagram, when you entered the diagram name in the Diagram Name text box, the Pool Name and Lane Name text boxes were populated with the same name. You can rename both the pool and the lane.  
If you are creating a Conceptual model, this option is not available.
5. Press OK to close the dialog. The new diagram appears in the Model View tree and a tabbed view opens in the Diagram View.

## Opening and closing diagrams

You can open and close diagrams to better manage system resources. When you open a project, all its diagrams remain closed. You can only work with a diagram and its elements when it is open.

### Opening diagrams

Do one of the following options to open a diagram:

- In the Model View tree, right-click the diagram node and click Open.

OR

- In the Model View tree, double-click the diagram.

OR

- In the Model View tree, select the diagram you want to open and press Enter.

### Closing diagrams

The following describe the various ways used to close diagrams.

- [Closing a Single Diagram](#)
- [Closing Other Diagrams](#)
- [Closing All Diagrams](#)

#### Closing a single diagram

To close any single diagram, do one of the following:

- In the Model View tree, right-click the diagram node, and then click Close. The diagram is closed and automatically saved.

OR

- On the Diagram window, right-click the Diagram View tab, and then click Close. A Save Resources dialog opens asking you if you want to save the changes. Click Yes and the diagram closes.

OR

- Click the  in the Diagram View tab for the opened diagram. A Save Resources dialog opens asking you if you want to save the changes. Click Yes and the diagram closes.

#### Closing other diagrams

You can close all the opened diagrams except the active one.

1. Right-click the Diagram View tab of the active diagram.
2. Click Close Others from the menu. If the other diagrams you are closing have been modified a Save Resources dialog opens asking you if you want to save the changes. Click Yes and all the 'diagrams close with the modifications saved.

#### Closing all diagrams

1. To close all open diagrams, right-click any Diagram View tab, and then click Close All.
2. If any of the diagrams you are closing have been modified a Save Resources dialog opens asking you if you want to save the changes. Click Yes and all the other diagrams close with the modifications saved.

## Exporting diagrams

You can export both Business Process and Conceptual diagrams in three different formats: rtf, pdf, and jpg. You can also export a [Conceptual](#) diagram to ER/Studio. Take the following steps to export a diagram:

1. Open the diagram you want to export in the Model View tree.
2. Once the diagram is opened, right-click the diagram node in the Model View tree and select Export....  
OR  
From the main menu, select File > Export > Diagram....
3. In the Export dialog, select the directory where you want to save the exported diagram, enter the file name, and select the type of file (jpg, rtf, or pdf).
4. Click Save and the exported file is saved in the selected file format. You can then open the exported file in the appropriate application.

## Deleting Business Process Diagrams

You can permanently delete any Business Process diagram listed in the Model View tree. To delete a diagram, do the following:

In the Model View tree, right-click the diagram, and then click Delete. If it is a Business Process diagram, it is associated with a pool having an invisible boundary which can also be deleted. So, in the Delete Diagram with Associated Pool dialog you are given two options.

Do you want to delete the associated pool, along with the elements it contains?	Click Yes the diagram, and all associated pools and lanes are deleted.
Do you want to delete only the diagram?	Click No. When this option is selected the invisible pool, its associated lane, and all elements in the lane are still in the Model View tree.

**NOTE:** You can undo the deletion by clicking Undo Delete Elements from the Edit menu. The diagram and all associated elements are restored in the Model View tree.

## Deleting Conceptual Model Diagrams

You can permanently delete any Conceptual Model diagram listed in the Model View tree. To delete a diagram, do the following:

1. Right-click the diagram node in the Model View tree and select Delete.  
OR  
Select the diagram node you want to delete in the Model View tree and click  on the toolbar.  
OR  
Select the diagram node you want to delete in the Model View tree and click the Delete key.
2. The Delete Items dialog box opens. Clicking Yes completely removes the selected diagram from the workspace.

**NOTE:** You can undo the deletion by clicking Undo Delete Elements from the Edit menu. The diagram and all associated elements are restored in the Model View tree.

## Renaming diagrams

You can rename a diagram in the Model View tree.

1. In the Model View tree, right-click the diagram node you want to rename and select Rename Diagram. If your diagram is unsaved, a warning dialog opens asking if you want to continue with the renaming process.
2. Click Yes and the Rename Diagram dialog opens.
3. Enter the new name in the text box and click OK. The diagram is renamed in the Model View tree.

## Printing diagrams

You can print the diagram you have created using ER/Studio BA. You can also save the print settings for the opened diagram. To open the Print dialog:

1. Open the diagram you want to print in the Diagram View.

Click  on the main menu.

OR

On the main menu, click File > Print.

OR

Press Ctrl+P. The Print dialog opens. The following settings are available:

Setting	Description
Printer...	When you click the Printer button the Print dialog opens where you can select the Printer you want to use.
Preferences	In this dialog, you can select the printer, set a page range, and set the number of copies you want to print. <b>Note:</b> Once you set your print options in this dialog, click <i>Print</i> to close this dialog. However, the diagram does not print until you click the <i>OK</i> button in the first <i>Print</i> dialog.
Scale	
Actual Size	The page is printed as is with no zoom.
Fit Page	All elements in the diagram are reduced to fit on one page.
Custom	You can set the percentage of the page you want printed. As you change the percentage in the combo box, notice that the information in the preview pane changes. As you increase the percentage a grid appears in the preview pane indicating where the page divisions appear.

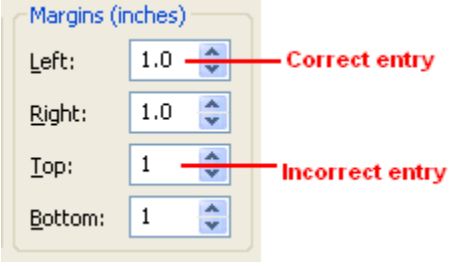
Setting	Description
Margins	
Inches	<p>Sets the margins for the page. As you increase the size of the margin, notice that the preview pane shows where the page divisions appear based on the margin size.</p> <p><b>Note:</b> The value you enter for the margin must contain the decimal separator. For example if you want one inch margins, you must enter 1.0, not 1.</p> 
Copies	
Number of Copies	Select the number of copies you want printed of the selected diagram.
Collate	Multiple copies are printed in order.
Options	
Center to Page	Centers the diagram in the center of the printed page.
Print Page Numbers	A page number is placed on each page as it is printed.
Print Border	When you select this option a border is placed around the printed diagram. You can set the width of this border.
Width	When you select the Print Border option, you can then set the width of the border.

- After you make any changes to the print options, click OK. The diagram is printed and any changes you made to the print options are saved with the diagram.

**NOTE:** Click Save Settings if you make print option changes and want to save these options without printing the diagram.

### Using the Diagram Usage dialog

The Diagram Usage dialog helps you quickly locate elements on one or more diagrams. There are two different ways of using this dialog:

- When you right-click on an element in the Model View, a pull-right menu lists the diagram(s). This allows you to quickly locate and open the diagram where the element appears. If the element appears on more than ten diagrams the *More...* option appears, opening a dialog listing all the diagrams.
- Right-click on an element in the [Search Results View](#) and select *Find In > All Diagrams*. The Diagram Usage dialog opens where you can select and open a diagram from those listed. You can also click  on the *Search Results* toolbar.

## Edit diagrams

When you select *Diagram* on the main menu, you gain access to four commands that help you edit diagrams:

- [Case Shift](#)
- [Grid](#)
- [Layout](#)
- [Connections](#)

### Case shift

You can set the case format for all element labels. When you make a selection, all labels in the diagram conform to the new selection. You have three options:

Command	Description
Lower Case	All text appears in lower case lettering, including the initial letter of the label.
Preserve Case	All text appears as it was entered for the label.
Upper Case	All text appears in upper case lettering.

### Grid

Rather than guessing at the alignment of your elements, you can use the lines of the grid as a guide. The grid, which you can turn on or off, is a network of lines that covers your diagram. The Snap Objects to Grid command is a toggle command that you can turn on or off as well.

Command	Description
Show Grid Lines	Select this command and grid lines appear in the diagram. You can change the <a href="#">preferences</a> so that the appearance of grid lines is the default setting for the application. The grid also displays in a pool, sub-process, or subject area. You can change the <a href="#">preferences</a> for this so the grid lines don't display.
Show Parent Objects as Transparent	When a parent object such as a pool, lane, or subject area is placed on a diagram, the grid lines appear in the object. You can change the <a href="#">preferences</a> to make it the default setting.
Snap Objects to Grid	Changes the default setting so that when an element is moved, it snaps to the nearest grid. This feature is active whether the grid lines are showing or not. You can change the <a href="#">preferences</a> so that the snap to grid action is the default setting for the application.

## Layout

When you change this setting you get a Change Diagram Layout dialog warning you that this selection overrides any changes you have made to individual relationships. For example, if the setting was *elbowed* when you created your diagram and you then change to *straight*, all connections are changed to the selected layout style.

Command	Description
Elbowed	All connections are drawn with ninety degree bends in the line. This is the default setting.
Straight	All connections are drawn as the shortest distance between the two elements you are connecting.

## Connections

Once you have created a link in the Diagram View, select this command to show or hide the links for the entire object in the diagram.

## Using Zoom In diagrams

You can change the scale of any diagram displayed in a Diagram View. The application offers several zooming features which are described in the following table:

Feature	Description
<a href="#">Preset Percentages</a>	You can enlarge or reduce a diagram using a present percentage. Note: You also have the option of setting a <a href="#">Custom</a> on the Standard Toolbar.
<a href="#">Custom Zooming</a>	Custom zoom into and out of any Diagram window by specifying a zoom percentage on the Formatting toolbar. When you use the custom zoom feature, you type a specific zoom percentage, or select a preset percentage from the custom zoom drop-down list. The higher the specified percentage value, the closer the zoom.
<a href="#">Zooming In and Out</a>	Incrementally zoom into and out of any Diagram window, enlarging or reducing the size of your diagram gradually with the click of a button.
<a href="#">Fit to Page</a>	Reduces the size of all elements in the Diagram View so that the entire diagram fits on one page.

**TIP:** ER/Studio BA also offers an [Overview Window](#), where you can zoom into and out of specific parts of any Diagram window from a single, unscalable window.

## Preset p ercentages

To enlarge or reduce a diagram using a preset percentage, do the following:

- 1 On the View menu, click Zoom Level.
- 2 From the pull-right menu, select the percentage amount that you want to enlarge or reduce your diagram. The available percentages are: 25, 50, 75, 100, 200, and 400.





## Custom zooming

You can gain access to the Custom Zoom feature three different ways:

- On the View menu, click Zoom Level > Custom to open the Zoom Level dialog.

OR

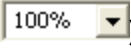
- On the Standard toolbar, click the Custom Zoom box (). In the Custom Zoom box, do one of the following:
  - Type a zoom percentage value.
- OR
- Select a preset zoom value from the list to display the diagram at the specified zoom percentage.

**TIP:** The custom zoom drop-down list also offers the option to [Fit to Page](#).

## Zooming in and out

To zoom in (enlarge the diagram), do one of the following:

- On the Standard toolbar, click .

OR

- In the Diagram View, right-click, and then click Zoom In.

To zoom out (reduce the diagram), do one of the following:

- On the Standard toolbar, click .

OR

- In the Diagram View window, right-click, and then click Zoom Out to redraw the diagram according to the zoom size specified.

## Fit to page

Fit to Page reduces or enlarges the diagram so all elements appear in the visible view area of the diagram.

- On the View menu, click Zoom Level > Fit to Page.

OR

- On the Standard toolbar, click the drop-down arrow in the Custom Zoom box  and click Fit to Page.







All elements in the Diagram View are reduced or enlarged so the entire diagram now fits on one page.

## Using diagram elements

The table below describes the different functions available when working with the diagram elements in ER/Studio BA.

Diagram Element Function	Description
<a href="#">Create New Elements</a>	Explains how to create and place elements in the diagram from both the Model View and the palette.
<a href="#">Label Diagram Elements</a>	Explains how to label elements placed in a diagram. You can also edit those labels.
<a href="#">Edit Diagram Elements</a>	Explains how to cut, copy, paste, select all diagram elements, select all similar diagram elements, delete elements, and change the diagram element size.
<a href="#">Format Diagram Elements</a>	You can format an individual element or a group of elements using the Formatting toolbar.

Right-click an element in the Model View tree to gain access to the following functions:

Command	Icon	Description
<a href="#">New</a>		You can create new elements from a lane node in a Business Process diagram, and from a Subject Area or Business Entity in a Conceptual Model diagram.
<a href="#">Rename</a>		You can rename elements two different ways.
<a href="#">Delete</a>		There are several different ways to delete elements.
<a href="#">Create Mapping</a>		This command is only available for a Subject Area element in a Conceptual Model. You can map a Subject Area to one or more Conceptual Model diagrams.
Diagram Mapping		This command is available if you have mapped a Subject Area to a Conceptual Model. Click this command and a pull-right displays the name of the diagram the Subject Area is mapped to.
<a href="#">Grid Editor</a>		This is a table-like editor which is an alternative to the Model View. Content in the Grid Editor can be printed or exported as a report.
<a href="#">Links</a>		This command opens the Create Link wizard which allows you to create links between elements.
<a href="#">Usages</a>		This command opens the Create Usage wizard which allows you to create usage connections between elements.
Impact Analysis		You have two commands available from the pull-right menu: You can generate an <a href="#">Impact Analysis Diagram</a> which graphically displays all the associated relationships and elements. You can also show the <a href="#">Impact Analysis Report</a> .
Refresh		Updates the currently displayed information with new data or changes.
Properties		Opens the <a href="#">Property View</a> for the selected element.



## Create new elements

ER/Studio BA offers two methods for creating new elements in the Diagram View: from the [palette](#), and from the Model View tree. How you create elements in the Model View tree depend on whether you are working the [Business Process Models](#) or [Conceptual Models](#). You can also create [multiple existing elements](#) from the Model View.

Creating new elements from the palette

To create any type of element in the Diagram View, do the following:

- 1 On the Palette, click the element icon you want to use.
- 2 In the Diagram View, click a location in the view to place the element.

**NOTE:** The cursor is in the multi-drop mode  so you can place as many elements as you need. Press ESC to exit the multi-drop mode. The cursor changes from  to . You can also set a [preferences](#) to disable the multi-drop mode globally.

Creating new elements in the Model view for a Business Process model

You can create a new element in the Model View tree from the lane node. Once you have created the element, you can drag the element onto an open diagram in the Diagram View.

To create any type of element in the Diagram drawing area, do the following:

- 1 In the Model View tree, right-click the lane node where you want to place the new element.  
**NOTE:** You can also create a new lane from the Pool node.
- 2 Select New and click the element you want created from the pull-right menu. The selected element is placed in the lane node.

You can then drag the elements that are not nested onto an open diagram.

Creating new elements in the Model view for a Conceptual model

You can create a new element in the Model View tree from several different nodes. Once you have created the element, you can drag the element onto an open diagram in the Diagram View.

To create any type of element in the Diagram drawing area, do the following:

- 1 To create a specific element:
  - o For a *Business Entity* or *Subject Area* element for a model, right-click the model node where you want to place the new element.
  - o For a new *Subject Area* to be nested in an existing *Subject Area*, right-click the *Subject Area* node where you want to nest the new element.
  - o For a *Business Attribute*, right-click the *Business Entity* where you want the new attribute to reside.
  - o For a new *Business Entity* to be nested in an existing *Business Entity*, right-click the *Business Entity* node where you want to nest the new element.

- 2 Select New and click the element you want created from the pull-right menu. The selected element is placed in the lane node.
- 3 You can then drag the elements that are not nested onto an open diagram.

### Creating multiple existing elements from the Model view

To place multiple diagram elements listed in the Model View tree on the Diagram View, do the following:

- 1 On the Model View, click the first element.
- 2 Press CTRL and click all remaining elements.
- 3 Drag the elements on the Diagram View and the elements are placed in the Diagram window. The application displays any links shared between elements.

### Label diagram elements

When you label the elements in a diagram you can use [autotype feature](#) for quick and easy labeling. You can also [edit existing labels](#).

### Using the Autotype feature

Once you have placed an element on a diagram you can use the autotype feature to label it. This feature enables you to start typing immediately in a text box that opens automatically.

The autotype feature has the following functions:

- As you enter text, it autowraps in the text box.
- You can use returns in the text box by pressing Ctrl+Enter. As you enter text, the text box continues to expand downward.
- The autotype text box is closed by clicking the mouse button in the diagram or by pressing Enter.

### Editing existing labels

You can edit existing labels for elements three ways:

- If it is a label outside the element, for example a start event, select the element you want to edit in the Diagram View and then click the label. An editable text box opens allowing you to change or replace the existing label.
- If the element itself is labeled, for example a task, select the element and just start entering text. It automatically goes into the autotype mode.
- Double-click the element and the Property View opens. You can change the label in the Name text box.
- Right-click an element in the Model View tree and select Rename from the context menu. The new label appears on the selected element and in the Model View tree.

## Edit diagram elements

Once you place a diagram element, you edit them in the following ways:

- [Renaming elements](#)
- [Deleting elements](#)
- [Cutting elements](#)
- [Copying elements](#)
- [Pasting elements](#)
- [Selecting all elements](#)
- [Selecting all similar elements](#)
- [Grouping elements](#)
- [Changing diagram element size](#)

### Renaming elements

You have two different ways of renaming an element in the Model View tree:



- Right-click the element node and select Rename.

OR

- Select the element and press F2. The element node name becomes editable.

### Deleting elements

You can delete elements from the [Model View tree](#) and the [Diagram View](#) area. When you delete elements you have different options presented to you in the Delete Element dialog depending on whether you are deleting the element from the Model View tree or from the Diagram View. The table lists the options available:

Location	Description
Remove	This command is available when you delete the element from the diagram only. The element and its associated metadata remain in the project to be used by this or other diagrams (the remove command affects the display only).
Delete	This action permanently removes the element from the project, including the visual display on the diagram, the element itself, and its associated metadata. <b>Note:</b> Because this delete action may include other diagrams sharing this element, click  in the Delete Items dialog to list all the diagrams that are affected by this deletion. You can set a <a href="#">preference</a> to turn this listing option off.
View diagrams on which the elements appear.	When you click  in the Delete Element dialog, a window opens displaying the diagram where the element resides as well as its connecting elements.
Cancel	No action is taken and the element remains in the project and on the diagram. The Delete Element dialog is closed.

**NOTE:** ER/Studio BA does not place deleted elements on the clipboard for future pasting.

## Deleting elements from the Model view tree

Do one of the following options to delete elements:

- 1 In the Model View tree, select the diagram element.
  - o From the main menu, select Edit and then click Delete.
- OR
- o Right-click the element and click Delete. The Delete Elements dialog opens.

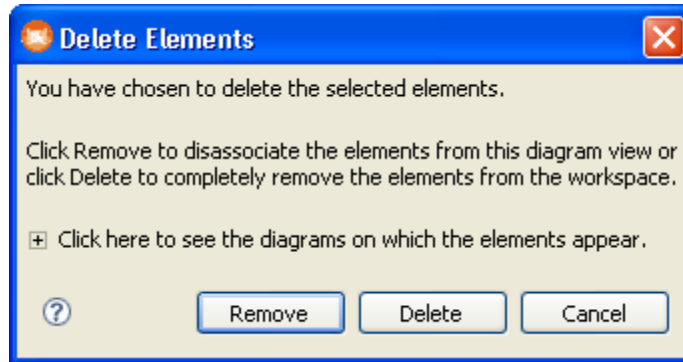

- 2 Click  to view all the diagrams on which the element(s) appear.

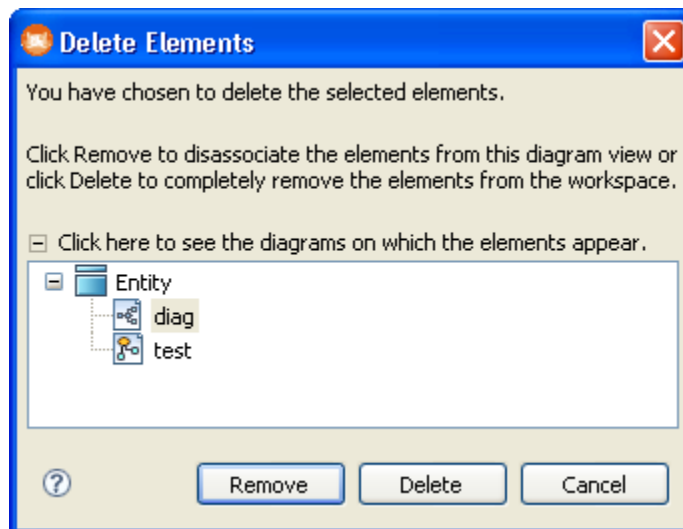

- 3 Click Yes to delete the selected element from the Model View tree.

**NOTE:** If you delete an element that resides on both the Model View tree and the diagram, and the diagram isn't open, when you open the diagram the deleted element no longer appears in the diagram.

## Deleting elements from the Diagram view

Do one of the following options to delete elements:

- 1 In the Diagram View, select the diagram element.
    - o On the Standard toolbar click .
- OR
- o Right-click the element, and, under Edit, click Delete.

The Delete Elements dialog opens.

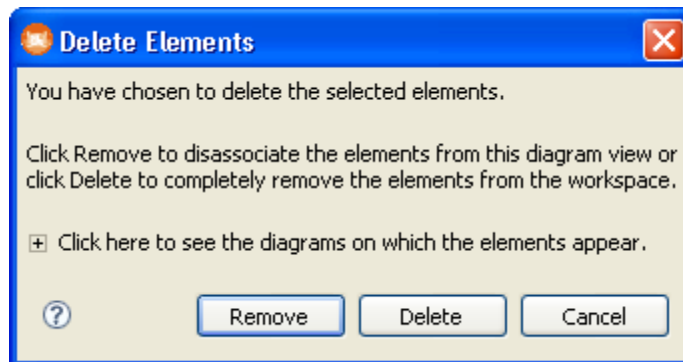

**NOTE:** The default preference setting is to display a list of the other diagrams that are using this element in the Delete Element dialog. When you click in the Delete Element dialog a window opens displaying the diagram where the element resides as well as its connecting elements. You can change this preference so this list no longer appears in the Delete Elements dialog.

- 2 Click  to view all the diagrams on which the element(s) appear.

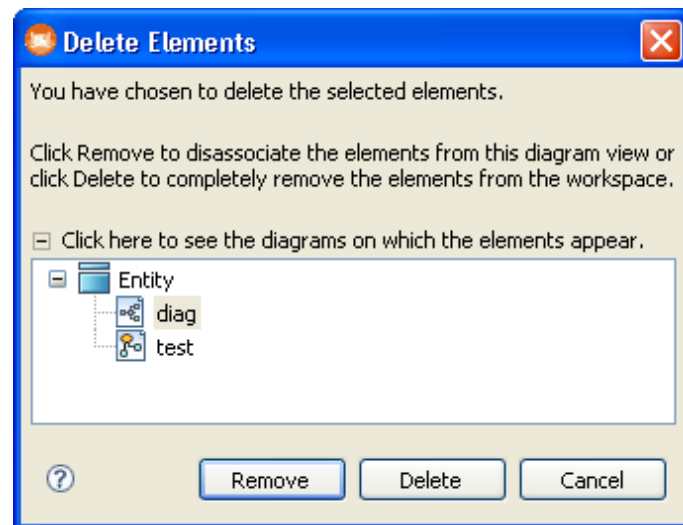



### 3 Click one of three choices:

- o Remove: Disassociates the element from the Diagram View.
- o Delete: Completely removes the element from the workspace.
- o Cancel: Cancels the actions and the element is not deleted.

### Cutting elements

You can cut most elements displayed in the Diagram View. When you cut an element, the application removes it from the window and places it on a clipboard. You can then [paste](#) the cut element in the same Diagram window, or in a different Diagram window in the same workspace, or in selected third-party applications like Microsoft Word®. The cut item remains on the clipboard until you cut or copy another selection.

**NOTE:** You cannot cut a lane within a pool.

To cut a selected element

- Right-click the element and select Edit > Cut.

OR

- Select the element and select Edit > Cut from the main menu.

OR

- Select the element and press Ctrl+X.

OR

- Select the element and click  on the Standard toolbar.

ER/Studio BA removes the element from the Diagram window, placing it on a clipboard for pasting.

### Copying elements

You can copy most elements displayed in a Diagram View. When you copy an element, the application leaves the original on the diagram and places a copy of it on a clipboard.

**NOTE:** You cannot copy a lane within a pool.

You can then [paste](#) the copied element in the same Diagram window, or in a different Diagram window in the same workspace, or in selected third-party applications like Microsoft Word® or Microsoft Visio®. The copied item remains on the clipboard until you cut or copy another selection.

**NOTE:** ER/Studio BA fully utilizes Window's copy buffer, letting you copy elements from any model for placement in Microsoft applications. Because the application automatically pastes copied graphics into third-party applications, you do not need to export images from ER/Studio BA for import into these applications.

To copy an element

- Right-click the element and select Edit > Copy.

OR

- Select the element and select Edit > Copy from the main menu.

OR

- Select the element and press CTRL+C.

OR

- Select the element and click  on the Standard toolbar.

ER/Studio BA copies the element, placing the duplicate on a clipboard for pasting.

Pasting elements

You can paste any cut or copied element into the following:

- same diagram
- different diagram in the same workspace
- different diagram in a different workspace
- external document such as Microsoft® Word.

**NOTE:** Pasting to an external application is done using the .jpg format so the image only appears in applications that supports the .jpg format.

When you cut or copy an element, the application places it on a clipboard for you to paste. The copied item remains on the clipboard until you cut or copy another selection. You can paste a symbol from the clipboard as many times as you want.

**TIP:** Cut or copied elements cannot be pasted into different model types. For example if you copied a Start Event from a Business Process model diagram, you cannot paste that event onto a Conceptual Model diagram.

**NOTE:** When you cut or copy an element in a diagram, when it is pasted to an external application, it is done using the .jpg format. Therefore the image will only appear in applications that can handle the jpg format.

To paste an element

- Right-click the background of the destination window, and then select Edit > Paste.

OR

- On the Standard toolbar, click .

OR

- From the main menu, select Edit > Paste.

OR

- Press CTRL+V.

## Selecting all elements

You can select all elements in a Diagram View. When you select a single element (by clicking the element), ER/Studio BA displays handles around the selected graphic. Likewise, when you select all elements, the application displays handles around every element in the window, letting you cut, copy, delete, or otherwise work with all elements at once.

To select all elements in a Diagram View

- On main menu select Edit > Select All.

OR

- Press CTRL+A.

OR

- Right-click an element in the diagram and select Edit > Select All.

## Selecting all similar elements

You can select all elements or links of a given type in the Diagram View. When you select a single element or link (by clicking it), ER/Studio BA displays handles around the selected graphic. Likewise, when you select all similar elements or links, the application displays handles around every element or link of the same type in the window, letting you cut, copy, delete, or otherwise work with them all at once. For example, when you click a task in a diagram, and then click Select All Similar Elements, ER/Studio BA selects all other tasks in the Diagram View.

To select all similar elements in a Diagram window

- Select the element, and on the main menu select Edit > Select All Similar Elements.

OR

- Select the element and press Ctrl+Shift+A.

## Grouping elements

This feature provides the ability to group elements together into a single entity that can be moved around a diagram in the Diagram View. Once items are grouped, a bounding box appears around the group items. They move together in a block and are essentially “locked” together, movement-wise. The Ungroup feature removes the grouping and allows the elements to be moved separately again.

The Group/Ungroup command is available on the Format main menu, the Alignment and Layout Toolbar, and on the shortcut menus of all elements (except the connecting elements). You can also use Ctrl+Shift+G to group and Ctrl+Shift+U to ungroup.

The following rules and constraints apply to the Grouping functionality:

- The Group command is only available if more than one item selected.
- The Ungroup command is only available if the item selected is in a group.
- If you select both the source and target elements, the connecting flow is also selected. If you select just one of the ends, the flow is not selected. However, when you move the grouped elements, the connecting flow remains connected to both the source and target and adjusts to the move accordingly.
- When doing a Copy and Paste, all grouped objects are copied and they are grouped together upon paste.
- The grouping is removed if only one presentation element remains in a group.

To group elements:

- 1 Select the elements you want to group by clicking and dragging a box around the select items. You can also select each item by holding down the left mouse button and clicking on each element in the diagram.
- 2 Right-click in any of the selected elements and click Grouping>Group. A bounding box appears around the selected elements.
- 3 Place the cursor on the bounding box and the cursor changes to the move cursor (↕).
- 4 Hold down the left mouse button and move the grouped items in the diagram.

**NOTE:** You can move elements within the group box. Click on the element you want to move and handles appear around the element. You can then move the selected element within the box. Note that the box stays in the same location.

### Changing diagram element size

You can change the size of any element in a Diagram window.

- 1 To change the size of an element, in the element’s Diagram view, click the element.
- 2 Drag the element handles to change its size.

### Format diagram elements

You can format an individual element or a group of elements using the Formatting toolbar.

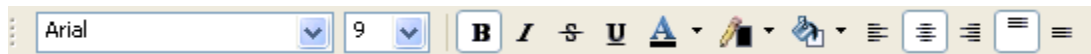

**NOTE:** You can also set global formatting preferences for both the Business Process Modeling and Conceptual elements by selecting Windows > Preferences. For more information, see [Formatting](#).



### Font and color options

You can change the font style, font size, font colors, and the fill and line colors of a selected element in the Colors and Fonts portion of the Formatting dialog.

To change a selected font, select a font from the drop-down menu in the Font text box. You can also change the font size by selecting a size from the drop-down menu in the size text box. You can edit the font settings of all element labels. The following toolbar commands are available:

Command	Icon	Description
Bold	<b>B</b>	Applies bold formatting to the label text.
Italics	<i>I</i>	Italicizes the label text.
Strikeout	<del>S</del>	A line is drawn through the label text.
Underline	<u>U</u>	Underlines the label text.



You can also change the font color, element outline color, and element fill color with the following commands.

Command	Icon	Description
Change Font Color		Click the drop-down arrow to select an existing color or click "Other" to open the Color dialog where you can create a custom color for the color of the label font.
Change Line Color		Click the drop-down arrow to select an existing color or click "Other" to open the Color dialog where you can create a custom color for the border of the element.
Change Fill Color		Click the drop-down arrow to select an existing color or click "Other" to open the Color dialog where you can create a custom color for the background of the element.

### Justification



You can change the justification settings for the text label in an element.

**NOTE:** These commands do not justify the text labels on elements that use text boxes outside the element.

Command	Icon	Description
Left Justify Text		Justifies the text on the left side of the text box.
Center Text		Centers the text in the text box.
Right Justify Text		Justifies the text on the right side of the text box.

### Font size









You can incrementally increase or decrease the text size of a selected element in the diagram.

Command	Icon	Description
Increase Font Size		Each time you click this icon, the font of the selected label increases by one point size.
Decrease Font Size		Each time you click this icon, the font of the selected label decreases by one point size.

## Reference objects

When you create a new workspace, reference objects are automatically created as well. You can create new reference objects three different ways: (1) in the [Model View](#); (2) by using the Reference Objects [Palette](#); or (3) by using the Reference Objects [Toolbar](#).

The table below lists the reference objects created when you create a new workspace:

Reference Object	Icon	Definition
<a href="#">External Data Objects</a>		You can import or create new external data objects and then <a href="#">link</a> those objects to business processes and tasks.
<a href="#">Business Element</a>		Elements are often used by business users to document their list of "terms and/or definitions". While from a business user's point-of-view, this may be no more than a list of terms, they can be used by a modeler to seed attributes of semantically-rich models. An element can be bound to different business attributes across conceptual models to enforce naming and definition standards. It is the The business element allows an organization to achieve a common meaning and lineage around core business concepts such as "customer", "customer identifier", "trade", etc.
<a href="#">Business Rule</a>		A business rule is a policy, practice, or formula related to the operation and enforcement of business practices.
<a href="#">Business Unit</a>		A business unit is an organizational area within or external to an enterprise.
<a href="#">Domains</a>		A reusable attribute template that promotes consistent domain definitions. You construct domains as you would attributes, specifying a name, datatype properties, null status, default values and validation rules.
<a href="#">Stewards</a>		A steward is a person or organization responsible to, or associated with a model element.
Link		This link displays high-level views of information requirements. This type is used to simply relate objects together.
Usage		When you select this option you create a link that enables you to designate a usage type: create, read, update, or delete database records. The link you create is labeled "usage"

Creating a reference object in the Model view

- 1 Right-click a reference object in the Model View tree and select New. The command that appears depends on the reference object clicked. For example, if you right-click on Business Rules, the command will be New Business Rule.

**NOTE:** If you right-click on [External Data Objects](#) and click New, a pull-right menu opens listing all available data objects.

- 2 The newly created reference object appears nested below the selected object in the Model View tree.

**NOTE:** Once you create the reference object, you can then drag that object onto the Diagram View. A representative icon is placed in the diagram. You can then link these objects to processes and tasks in the diagram.

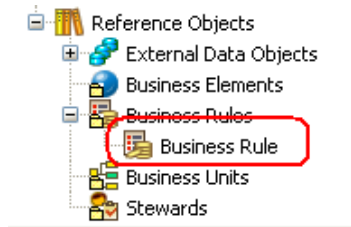

- 3 Right-click the newly created object to gain access to the following functions:



Command	Icon	Description
Rename		When you select this command or press F2, the text label for the object can be edited.
Delete		When this command is selected, the Delete Elements dialog opens asking you to confirm the delete action.
<a href="#">Links</a>		This command opens the Create Link wizard which allows you to create links between elements.
<a href="#">Usages</a>		This command opens the Create Usage wizard which allows you to create usage connections between elements.
Impact Analysis		You have two commands available from the pull-right menu: You can generate an <a href="#">Impact Analysis Diagram</a> which graphically displays all the associated relationships and elements. You can also show the <a href="#">Impact Analysis Report</a> .
Refresh		Updates the currently displayed information with new data or changes.
Properties		Opens the <a href="#">Property View</a> for the selected reference object.

Creating a reference object using the Reference Objects palette

- 1 Expand the Reference Objects portion of the Palette and select the reference object you want in your diagram.
- 2 Click once in the Diagram View and the object is placed in both the Model View tree and the diagram.

**NOTE:** The cursor is in the multi-drop mode so you can place as many elements as you need. Press ESC to exit the multi-drop mode. The cursor changes from to .

3 Right-click the newly created object to gain access to the following functions:

Command	Icon	Description
Connections		Once you have <a href="#">created a link</a> , select this command to show or hide all the links on the diagram.
Edit		The available commands are: cut, copy, delete, or select all.
<a href="#">Links</a>		This command opens the Create Link wizard which allows you to create links between elements.
<a href="#">Usages</a>		This command opens the Create Usage wizard which allows you to create usage connections between elements.
Impact Analysis		You have two commands available from the pull-right menu: You can generate an <a href="#">Impact Analysis Diagram</a> which graphically displays all the associated relationships and elements. You can also show the <a href="#">Impact Analysis Report</a> .
<a href="#">Creating as Pool</a>		This command is available only for the business Units and Stewards reference objects. This command creates a pool that is semantically linked to either a Business Unit or Steward.
<a href="#">Detaching from Pool</a>		This command is available only for the business Units and Stewards reference objects. This command deletes the link between the reference object and the pool.
Properties		Opens the <a href="#">Property View</a> for the selected reference object.

### Creating a reference object using the toolbar

1 Click the Reference Object you want to place in the Diagram View from the toolbar.

**NOTE:** If this toolbar is available, select View > Toolbars > Reference Objects from the main menu.

2 Click once in the Diagram View to place the object.

Note that the object you just placed also appears in the Model View tree under the appropriate Reference Object node. For example, if you placed a Business Rule object in the diagram, a new Business Rule node appears under the main Business Rules node.

### Using business elements

Business Elements are often used by business users to document their list of “terms and/or definitions”. While from a business user’s point-of-view, this may be no more than a list of terms, they can be used by a modeler to seed attributes of semantically-rich models. A “business element” can be bound to different business attributes across conceptual models to enforce naming and definition standards. An organization can achieve a common meaning and lineage around core business concepts such as “customer”, “customer identifier”, “trade”, etc. by using the business element concept.

In Conceptual Modeling, a business element can be used like a domain is used at the logical level. Business Elements can be “[bound](#)” to business attributes to seed a conceptual model and enforce standards.



## Using business rules

A business rule is a policy, practice, or formula related to the operation and enforcement of business practices. You can create a new business rule in the Reference Objects node:

- 1 Right-click on the Business Rules node in the Model View tree and select New. The command that appears depends on the reference object clicked. So when you right-click on Business Rules, the command will be New Business Rule.

The newly created reference object appears nested below the selected object in the Model View tree. When you right-click the newly created object you gain access to a shortcut menu where you can rename or delete the Business Rule. You can also view the [Impact Analysis Report](#). You can [create a link](#), and open the [Property View](#) for the selected business rule. You can also double-click an object to open the Property View.

- 2 Once you create the reference object, you can then drag that object onto the Diagram View. A representative icon is placed in the diagram. You can then link these objects to processes and tasks.

## Using business units

A business unit is an organizational area within or external to an enterprise, for example, Human Resources, Sales, Accounting, etc. You can create a new business unit in the Reference Objects node. You can create a [pool](#) from a Business Unit or [detach](#) a pool from a Business Unit.

### Creating a new business unit

- 1 Right-click on the Business Units node in the Model View tree and select New. The command that appears depends on the reference object clicked. So when you right-click on Business Units, the command will be New Business Unit.

The newly created reference object appears nested below the selected object in the Model View tree. When you right-click the newly created object you gain access to a shortcut menu where you can rename or delete the Business Unit. You can also view the [Impact Analysis Report](#). You can [create a link](#), and open the [Property View](#) for the selected business unit. You can also double-click an object to open the Property View.

- 2 Once you create the reference object, you can then drag that object onto the Diagram View. A representative icon is placed in the diagram. You can then link these objects to processes and tasks.

### Creating as a pool

Conceptually a pool represents the participant in a process - the “who” of the action. Since a list of Business Units and Stewards is maintained in the Reference Objects, which also represent the “who”, you can semantically link the two objects. For example, you can keep track of the business units in your organization in the Reference Objects, for example Sales, Documentation, Engineering, etc. You then want to show the process that Documentation goes through to get ready for a software release.

Rather than create a new pool called “Documentation”, it’s better to use the existing object to semantically link them so that we understand that it’s the same business unit we’re talking about. This avoids redundancy because you can define it once and use it multiple times. Because the two objects are “bound” if you change the name of the business unit/steward you also change the name of the pool.

## Detaching from a pool

Once you have created a Business Unit or Steward as a pool you can eliminate the relationship between the reference object and the pool.

Right-click the reference object either in the Model View tree or in the diagram and select Detach from Pool. The link is deleted between the reference object and the pool. Any changes you make to the reference object are no longer propagated to the pool. However both the reference object and the pool remain on the diagram.

## Using domains

Domains are reusable attribute templates that promote consistent domain definitions. You construct domains as you would attributes, specifying a name, datatype properties, null status, default values, and validation rules. After creating domains, you can re-use them in your data model by applying them to attributes and table columns.

For more information see

- Dragging and Dropping Domains on Business Entities
- Importing ER/Studio Data Architect Domains as ER/Studio BA Domains

By defining a Domain, you can then propagate changes to the underlying domain definition to all attributes and table columns that reference it.

**NOTE:** Domains are not visualized on diagrams so the Domain element icon is not available on the Reference Object's toolbar or palette.

One important method for enforcing business rules is to define and to apply domain restrictions. Domain integrity refers to the rules governing what values an attribute can take. By restricting and validating an attribute's values, you can implement important business rules such as ensuring that a checking account maintains a positive balance, or preventing the entry of invalid phone numbers.

### Dragging and dropping domains on business entities

Dragging/dropping of Domains to Business Entities are allowed. A Business Attribute is created using the domain name if an attribute with that name doesn't already exist. If an attribute with that name already exists, a unique name is assigned to the attribute.

### Importing ER/Studio Data Architect domains as ER/Studio Business Architect domains

- The ER/Studio DA domain data type will be created as the ER/Studio BA domain's data type.
- The ER/Studio DA width will be created as the ER/Studio BA domain's width.
- The ER/Studio DAscale will be created as the ER/Studio BA domain's scale.
- The ER/Studio DA "allow nulls" property will be created as the ER/Studio BA domain's "Optionality" property. Allow nulls is equivalent to 'optional'.
- The enforcement options on the domains will be set from the "allow override" options of the ER/Studio DA domain.
- The business attributes will be bound to the domains as per the ER/Studio DA model.
- Since domains do not enforce description/notes from the domains, the descriptions and notes will be set on the business attribute, but there is no enforcement from that point on. Same for attribute names.

## Importing ER/Studio domains as business elements referencing domains

- The domain's name will be created as both the business element's name and the ER/Studio BA domain's name. The "enforce name" option will be cleared on the business element (i.e. not enforced).
- The domain's description will be created as the business element's description.
- The domain's notes will be created as the business element's notes.
- The domain's data type will be created as the ER/Studio BA domain's data type.
- The ER/Studio DA width will be created as the ER/Studio BA domain's width.
- The ER/Studio DA scale will be created as the ER/Studio BA domain's scale.
- The ER/Studio DA "allow nulls" property will be created as the ER/Studio BA domain "Optionality" property.
- The enforcement options on the domains will be set from the "allow override" options of the ER/Studio DA domain.
- The business element will point to the domain.
- The business attributes will be bound to the business elements as per the ER/Studio DA model.

## Using stewards

A steward is a person or organization responsible for or associated with a model element, for example: DBA, Auditor, Jeffrey Smith, etc. You can create a new steward in the Reference Objects node. You can also create a pool from a Steward.

You can create a [pool](#) from a Steward or [detach](#) a pool from a Steward.

### Creating a new steward

1. Right-click on the Stewards node in the Model View tree and select New. The command that appears depends on the reference object clicked. So when you right-click on Steward, the command will be New Steward.

The newly created reference object appears nested below the selected object in the Model View tree. When you right-click the newly created object you gain access to a shortcut menu where you can rename or delete the Steward. You can also view the [Impact Analysis Report](#). You can [create a link](#), and open the [Property View](#) for the selected steward. You can also double-click an object to open the Property View.

2. Once you create the reference object, you can then drag that object onto the Diagram View.

A representative icon is placed in the diagram. You can then link these objects to processes and tasks. The example below shows a steward linked to a task via an association.

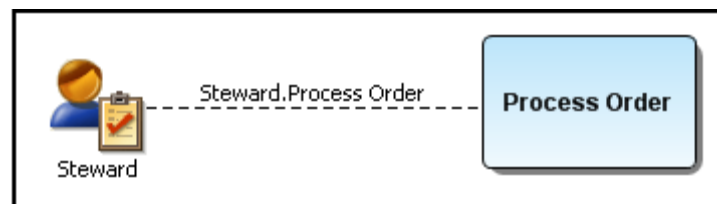

## Creating as a pool

Conceptually a pool represents the participant in a process - the “who” of the action. Since a list of Business Units and Stewards is maintained in the Reference Objects, which also represent the “who”, you can semantically link the two objects. For example, you can keep track of the business units in your organization in the Reference Objects, for example Sales, Documentation, Engineering, etc. You then want to show the process that Documentation goes through to get ready for a software release.

Rather than create a new pool called “Documentation”, it’s better to use the existing object to semantically link them so that we understand that it’s the same business unit we’re talking about. This avoids redundancy because you can define it once and use it multiple times. Because the two objects are “bound” if you change the name of the business unit/steward you also change the name of the pool.

## Detaching from a pool

Once you have created a Business Unit or Steward as a pool you can eliminate the relationship between the reference object and the pool.









- Right-click the reference object either in the Model View tree or in the diagram and select Detach from Pool. The link is deleted between the reference object and the pool. Any changes you make to the reference object are no longer propagated to the pool. However both the reference object and the pool remain on the diagram.

## External data objects

You can [import](#), [export](#), or [create](#) External Data Objects (EDOs). These objects can then be [shown](#) on a diagram. You can use an External Data Object (EDO) in a diagram for [reference](#) or for [data flow diagramming](#). You can then [link](#) to EDOs with a specific business process or task. You can also link the [Individual Elements](#) (attributes, columns, and data elements) contained in these External Data Objects.

There are two different types of EDOs: Logical and Physical. The Logical types are entities and attributes. The Physical types are tables and views.



The table below lists the different types of EDOs.

Type	Icon	Description
Logical		
Data Source		
Data Feed		
Data Store		A data store is a repository for data.
Entity		Distinguishable objects that can be represented in a database.
Flat File		A flat file is a file containing records, one record per line. Fields may have a fixed width with padding, or delimited by white space or tabs or commas (CSV) or other characters. There are no structural relationships.
Report		
Physical		
Table		A set of data in a database.
View		

### Individual elements

The Individual Elements only appear on the Impact Analysis Diagrams when they are linked to a source object. They cannot be displayed on a Business Process or Conceptual Modeling diagram. Also, these Individual Elements are not available on the External Data Objects Toolbar or Palette.

The table below lists the individual objects contained in External Data Objects:

Type	Icon	Description
Attribute		An Attribute is a subset of an Entity
Column		An individual column of data within a Table or View.
Data Element		An individual piece of data in a Data Store, Data Feed, Report, or Flat File

### External data objects on a diagram

Once you have imported or created External Data Objects, these objects can be visualized on a diagram by dragging the object from the tree to the diagram in the Diagram View, or from the tree to the diagram node on the tree. Representative icons are then placed in the Diagram View. Once on the diagram, you can open the [Property View](#) for that object.

### Instantiating data objects for reference

You can instantiate an External Data Object on a business process diagram. The following example shows that the customer data table is used and/or referenced by the Customer Pool through an association to a table object.

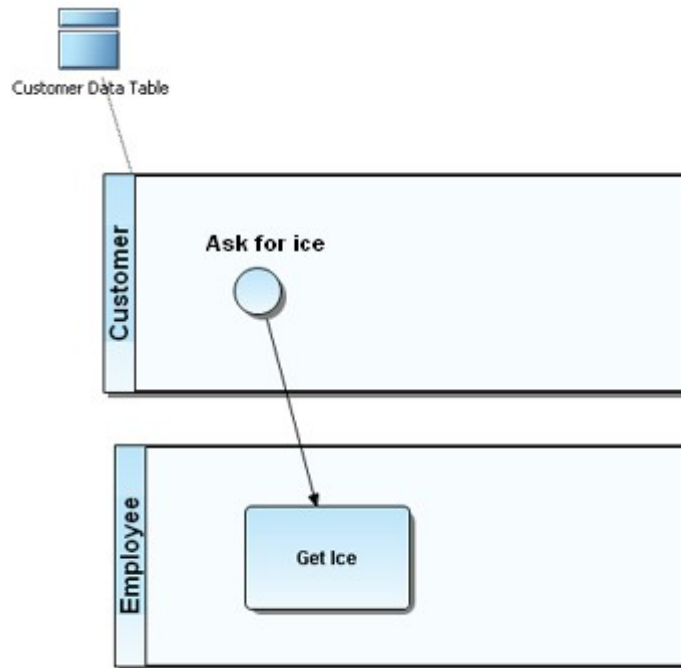

### Instantiating data objects for data flow diagramming

You can use combinations of data objects and Business Processing Modeling Objects to create data flow diagrams. In the following example there is no limitation/validation on how objects are used (for example, the data object can be either a source or a target for a sequence flow).

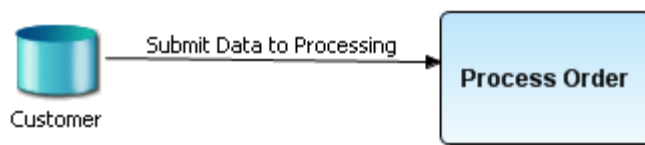

### Linking business processes to data

You can use the [create link wizard](#) to associate External Data Objects with other objects and then view it in an [Impact Analysis Diagram](#). For example, you may want to associate data objects with specific business processes or tasks.

### Creating external data objects

You can create and define generic External Data Objects to represent a high-level description of what data is accessed or data for which a model or database structure is not known (for example external data feeds from a company like JD Edwards). Once you create an external data object, you can [create](#) individual elements as well.

To create an external data object:

- 1 In the Model View, right-click the External Data Objects node in the Reference Objects node and select New. The pull-right menu lists all the available [types](#) that can be created.
- 2 Select the type from the list and the selected type is placed in the External Data Object node. The label, which you can edit, is the type name. You can then drag this object onto the diagram.

OR

Select the external data object icon from the External Data Objects Palette and click once in the Diagram View to place it. The object placed in the Diagram View automatically appears in the Model View tree.

OR

Select the external data object icon from the External Data Objects Toolbar and click once in the Diagram View to place it. The object placed in the Diagram View automatically appears in the Model View tree.

You can define all elements of the newly created external data object in the [Property View](#).

Creating individual elements

- 1 In the Model View, right-click the External Data Object you have created. For example, you can right-click on an Entity EDO and create an Attribute.
- 2 From the pull-right menu select the individual element (attributes/columns, or data) you want to create.

**NOTE:** You can also create an element from an External Data Object node by pressing insert, or by pressing insert on an existing individual element.

- 3 The individual element appears in the Model View in an editable mode. Rename the element.
- 4 Double-click on the element to open the Property View where you can set or change the element's properties.

Deleting external data objects

You can delete external data objects either from the Model View tree or from the Diagram View.

Deleting objects from the Model view

- 1 Right-click the external data object that you want to delete in the External Data Objects node.
- 2 Select Delete and the Delete Items dialog opens.
- 3 Click Yes and the item is removed completely from the workspace.





### Deleting objects from the Diagram view

- 1 Right-click the external data object that you want to delete in the Diagram View and select Edit > Delete.

In the Delete Elements dialog you have three choices:

Location	Description
Remove	This command is available when you delete the element from the diagram only. The element and its associated metadata remain in the project to be used by this or other diagrams (the remove command affects display only).
Delete	This action permanently removes the element from the project, including the visual display on the diagram, the element itself, and its associated metadata. Note: Because this delete action may include other diagrams sharing this element, click + in the Delete Items dialog to list all the diagrams that are affected by this deletion.
Cancel	No action is taken and the element remains in the project and on the diagram. The Delete Element dialog is closed.

- 2 Select the option you want and click OK.

## Drawing shapes

Drawing Shapes are used to provide additional information about the Process. There are [nine drawing shapes](#), one text label, and one line. You can use these shapes to create diagram objects without the semantic meaning implied by the modeling notations. The drawing shapes are displayed in the Model View tree. You can rename these shapes in the tree.

### Characteristics:

- The size of the shapes can be increased or decreased
- The line and fill colors can be changed
- The shapes can be labeled

When you right-click the drawing shapes you gain access to a shortcut menu where you can show the name of the shape, or edit it. You can also view the [Impact Analysis Report](#). You can [create a link](#), and open the [Property View](#) for the selected shape. You can also double-click an object to open the Property View.

### Setting preferences for shapes

You can set global preferences for the drawing shapes. The changes you make in this preferences dialog are then applied to all future elements you place in the Diagram View. For example, if you change the fill color of an octagon to red, from now on, all octagons you place in the Diagram View are red.

- 1 To open the Preferences dialog select Windows > Preferences on the main menu.
- 2 Expand the Formatting node and select Shapes.

# Working with ER/Studio Repository

The Repository provides access to workspaces for one person at a time. Modelers can update or delete model information simultaneously by working with ER/Studio® Business Architect in the normal fashion and by merging their changes into a single model.

To use Repository operations such as check in, check out, and get workspace, you must first specify the Repository connection details and then log in to the Repository.

When you are finished working with the Repository, you should log out. If you close ER/Studio Business Architect, you are automatically logged out of the Repository. This section provides usage information for Repository Users:

- [Specifying Repository connection details](#)
- [Logging in and out of the Repository](#)
- [Establishing security for the Repository](#)
- [Working with objects in the Repository](#)

**NOTE:** Repository architecture, setup, maintenance, control, and query options are covered in the “Administrator’s Reference” of the ER/Studio Data Architect Users Guide.

## Specifying Repository connection details

Using configurable Repository settings you can specify and modify server check out policy and communication settings.

### Setting Repository options

1. Click Window > Preferences.
2. Specify your connection details in the Repository Options and click Apply and then click OK to exit the editor.

The following describe options that require additional explanation:

- o Server Machine: Specify the URL or hostname of ER/Studio Repository.
- o Server Port: Specify the port ER/Studio BA uses to communicate with the Repository server. The default is 54333.
- o Check out model when checking out diagram: Choose what action, if any, you want the system to perform with respect to the models in a diagram, when a diagram is checked out; *always* check out the models, *never* check out the models, or *prompt* you to decide what to do each time a diagram is checked out.
- o Check out workspace when creating/deleting models: Choose what action, if any, you want the system to perform with respect to the workspace, when a model is checked out and deleted or when diagram is checked out and a new model is added to it; *always* check out the workspace, *never* check out the workspace, or *prompt* you to decide what to do each time a workspace is checked out.

## Logging in and out of the Repository

To log in to the Repository:

1. Click Repository > Log In.
2. Complete the log in dialog and then click OK.

The following describes the options that require additional explanation:

- o User Name: Enter your user name. This is case-sensitive.
- o Password: Enter your password. This is case-sensitive. You can change your password, click Repository > Security > Change Password.
- o Remember me: Select this option and ER/Studio BA will remember and then auto complete the User Name and Password for you when you choose to log in.

### Notes

- During the Repository Installation, a default user name and password `Admin` is set as the default. The Administrator should change the Admin password after the initial log in.
- The Admin user can't be deleted. This prevents an accidental lockout. In the ER/Studio Security Center, you can set up additional users with Roles and Privileges to maintain Repository security.
- If an administrator changes the repository security, users must log in again to update their permissions.

To log out of the Repository:

- To log out of the Repository, click Repository > Log Out.

## Establishing security for the Repository

Security of the Repository contents is managed through the Repository Security Center by creating and then assigning users particular Roles and Privileges.

**NOTE:** To prevent an accidental lockout, the Admin user can't be deleted.

The Administrator can restrict user access to Repository items at the workspace level. To restrict access to the Repository, the administrator creates users and then assigns the users a role, which grants specific permissions to the user, or the administrator creates new roles to assign to users. Then the Administrator can grant users full access to some Repository items and restrict or deny access to other items.

Before creating users and roles, the Administrator should understand the following Repository concepts:

- Client Side Security Caching: To promote the concept of detached modeling collaboration (e.g. being logged out of ER/Studio Repository and possibly detached from the network), all security associated with the user by diagram is cached on the client when the user logs into ER/Studio Repository.

**NOTE:** When security changes are made, users must re-login to update their permissions.

- **Super User:** Super User is a default Role created upon installation of ER/Studio Repository. The default 'Admin' user is assigned to the Super User role. This user can do anything to Repository objects, users and roles managed in the ER/Studio Repository as it is granted all privileges. It is not removable or editable, and is only found at the 'Repository' level of the Repository Security area of the Security Center.
- **No Access:** No Access is a role that can be applied only at the workspace level of the Repository. It is a quick and global mechanism to prevent any access whatsoever to certain workspaces.

#### Notes

- When a user checks out a workspace from the Repository, ER/Studio BA tracks the user and machine combination for that particular file. In addition, to enable users to model while they are "offline" or unable to connect to the Repository server, when a workspace is checked out, ER/Studio stores information about the security rights of the user and the workspace with the file, which has the following effects:
- When a user is logged into the Repository, and attempts to open a workspace that was retrieved from the Repository by a different user/machine combination than the currently logged in user, ER/Studio BA indicates that the file cannot be opened due to the conflict. This ensures that one user does not attempt to work on or check in changes to a workspace that was originally retrieved by a different user. Because the Repository keeps track of object check outs based on the user and machine, only the user on the machine that originally checked out an object can check it back in.
- Even if a user is not logged into the Repository, Repository files that have been checked out can be opened and worked on in ER/Studio BA. ER/Studio BA will load the security permission data for the user that originally retrieved the file from the Repository, and that security data will govern the rest of the working session until the user either logs in to the Repository or closes the file. If multiple files are open while the user is NOT logged in to the Repository they must all have been retrieved by the same user. Of course, this also applies when the user IS logged in.
- The cached security data stored with each diagram is updated whenever an open Repository file is saved while logged in to the Repository, but if the file is not saved before closing it, then any changes to the security permissions for that user and workspace will not be cached with the file. So, if you plan to work offline, and the security settings have changed since the file was last saved, then you should open each file while logged into the Repository and save it before taking the files to work offline.
- If an admin makes changes to the security UI, such as changing permissions on workspaces to grant or revoke access, users must re-login to update their permissions.

This section includes the following topics:

- [Creating and managing roles](#)
- [Creating and managing users](#)
- [Granting and prohibiting user access to Repository items](#)

See Also

Working with Objects in the Repository

## Creating and managing roles

ER/Studio BA supports customized roles with different sets of permissions. Repository Object Type Permissions are pre-defined privileges to operate on Repository items. You can assign them to a role, which gives users assigned to that role, permission to perform certain Repository operations. You can use the available privileges to create specific roles to suit your environment.

For example, you can create a role which has the Repository permissions to create, update, and delete workspaces. You can then assign a new user that role for the Repository and then create and assign another role to provide update privileges to existing workspaces the user may need to update.

**NOTE:** To access, create, update, and delete user and roles, a Repository administrator must have Access Security Info and Update Security Info privileges.

### Create, update, rename, and delete roles

- 1 Click Repository > Security > Security Center.
- 2 Select the Manage Roles tab.
- 3 *To create a new role, click New.*
  - o In the Create Repository Role dialog, enter a Name and a Description for the new role.
  - o In the Repository Object Type Permission area, select the permissions you want to assign to the role for the selected object type.
  - o Click Apply and continue changing security settings and then when finished, click OK to exit the security center.
  - o To apply the new role to existing users, see [Assigning Users Roles for Accessing Repository Items](#).

*To update a role, select a role from the list, select or clear the checkboxes to add or remove permission, click OK, and then click OK again to exit the security center.*

*To delete a role, select a role from the list and then click Delete.*

*To rename a role, select a role from the list and then click Rename.*

- o In the Rename Repository Role dialog, enter a new name, click OK, and then click OK again to exit the security center.
- 4 Inform affected users that they should log out of the Repository and then log in again to receive the security updates.

### Notes

- Once created, the Administrator can select the role and update, delete or rename it at any time. Renaming the role does not affect the privileges users have, but if you delete a role users who had access to Repository items through that role, will no longer have access to those items.
- Users cannot modify workspaces without the necessary permissions, regardless of whether the user has the workspace checked out.
- Once you delete a role from the Repository, it will no longer be in the database.

- The following lists the Repository Object Types, the permissions you can grant, and the common operations these permissions give access to:

Repository Object Types	Repository Object Type Permissions	Permitted Operations
Repository	Access Security Info	Security Center: View settings
	Update Security Info	Security Center: View and change settings
	Create Workspace	Add Workspace
	Update Workspace	Check Out Workspace, Check In Workspace Check Out Object(s), Check In Object(s) Undo Check Out Workspace, Undo Check Out Object(s)
	Delete Workspace	Delete Workspace If you delete a workspace in Repository, the file itself remains on the local disk.

## Creating and managing users

Managing users entails creating, changing, and deleting user account permissions and logins, and activating and deactivating their accounts. Using Roles, you can choose the permissions granted a user for the Repository item.

**NOTE:** To access, create, update, and delete user information, a Repository administrator must have Repository Object Type Permission, Access Security Info and Update Security Info privileges.

Create, edit, delete, deactivate, reactivate, and check in users

- Log in to the Repository.
- Click Repository > Security > Security Center.
- Click the Manage Users tab.
- On the Manage Users tab, you can manage users by clicking their name in the list and then clicking a management option and following the prompts as required.
- Continue making security changes and then click OK to exit the security center.
- To assign permissions to users, see [Assigning Users Roles for Accessing Repository Items](#).
- Notify users that they must log out and then log in again to receive the security updates.

Notes

- You cannot delete or deactivate the Admin user, but you should change the Admin password from the default, which is Admin.
- The new user appears in the user list with a star indicating that this user does not yet have any roles assigned to it for any Repository items.

- Users must log out and log in again to receive any security updates.
- The Admin does not need to know the user's password to create a new password for the user.
- The Admin can look to the Manage Users tab to find out which users are logged in to the Repository and whether or not they currently have items checked out. Knowing if users have items checked out is particularly useful when upgrading the Repository, because after before upgrading the Repository the users should check all their items in and then do a clean get and check out of the items when the upgrade is complete. Knowing which users are logged in is useful when changing security center settings because after making any setting changes, the Admin should request online users to log off and log in again to receive the security center updates.
- The Administrator may want to deactivate a user to prevent the user from logging into the server while the Repository is being updated. Once deactivated the user must be reactivated before they can log in to the Repository.

## Granting and prohibiting user access to Repository items

On the Repository Security tab of the Security Center, users with the appropriate privileges can assign other users the appropriate access privileges for different objects, granting them permission to perform specific operations on a Repository item and prohibiting them from performing other operations on the same object.

### Assigning users roles for accessing Repository items

- 1 Log in to the Repository.
- 2 Click Repository > Security > Security Center.
- 3 Click the Manage Roles tab; explore the available roles to determine if an existing role provides the access you want to grant the user. If necessary, create a new role with the appropriate permissions.
- 4 *To grant permission to access and update security information, or to view only workspaces, in the Repository Object pane, select Repository.*

*To grant permission to update or delete an existing workspace, in the Repository Object pane, expand Repository and select the name of a workspace.*

- 5 In the Available Users pane, click and drag a user name onto the name of the role you want to apply to the user for the Repository or for the selected workspace.
- 6 Click Apply and then click OK to exit the Security Center.
- 7 Notify users that they must log out and then log in again to receive the security updates.

**TIP:** To remove the role assignment of a user to a Repository item, click the Repository item, drag the user name from under role onto another role in the Available Roles area or drag the user name back to the Available Users pane.

## Notes

- A user can only have one role for each object. But a user can have different roles for different objects.
- If a user is listed in the Available Users area, but is unselectable, the user has been deactivated and must be reactivated before you can modify the user.

## Prevent users from accessing specific Repository items

The system-defined No Access role can prevent a user from accessing selected projects or diagrams

- 1 Log in to the Repository.
- 2 Click Repository > Security > Security Center.
- 3 In the Repository Object area, navigate to and then click to select the workspace you want to secure from specific users.
- 4 From the list of users in the Available Users area, click a user name or CTRL-click several names and then drag the users onto the No Access role in the Available Roles area.
- 5 Repeat step 3 and step 4 as required to secure other diagrams and projects.
- 6 Click Apply, continue changing security settings if required, and then click OK to exit the security center.

## Change user access to Repository items

To change user access to Repository items, change the permissions of the role the user has for the Repository item or assign another role to the user for that particular Repository item.

# Working with objects in the Repository

The Repository performs version control and allows other users to retrieve a copy of the workspace to view or edit on their local machines if they have permission.

The Repository includes a robust features set for working with workspaces. Detailed procedures for using these features are provided in subsequent sections.

- [Adding a workspace to the Repository](#)
- [Retrieving a Repository workspace](#)
- [Getting the latest version of a workspace](#)
- [Saving changed items to the Repository \(Checking in\)](#)
- [Checking out Repository items](#)
- [Discarding changes made to a checked out workspace](#)
- [Deleting workspaces from the Repository](#)



## Adding a workspace to the Repository

Using the Add Workspace operation you can add the active workspace to the Repository.

**NOTE:** You cannot add data model objects to the Repository without first adding the workspace containing them.

- 1 Log in to the Repository.
- 2 Click Repository > Workspace > Add Workspace.
- 3 Enter a comment if you want to and then click OK to exit the dialog and complete the operation.

When an object has been added to the Repository, the object icon changes to include a little database icon in the upper left-hand corner.

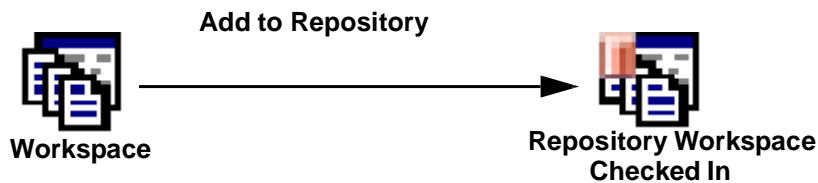

## Retrieving a Repository workspace

Retrieving a workspace in the Repository downloads a copy of the selected workspace from the Repository onto your local machine. If a local version of the workspace exists, the *Get from Repository* operation refreshes the local copy with the version from the Repository.

**NOTE:** Permissions assigned to your user account in the Repository Security Center determine what type of access you have to Repository objects. For more information, see [About Repository Permissions](#).

- 1 Log in to the Repository.
- 2 Click Repository > Workspace > Get Workspace.
- 3 In the Repository Get Workspace Selection dialog, scroll through the list of available workspaces, select the workspace you want, and then click OK.

**NOTE:** You can also get a workspace through the Welcome to ER/Studio Business Architect dialog that appears each time ER/Studio BA is started.

## Getting the latest version of a workspace

The Get Latest Version function synchronizes the local version of the open workspace with the version in the Repository, copying the Repository version to local storage and overwriting the local copy. For example, if another user has changed the workspace since you last checked it in, you can get the latest version to update your local version after they submit their changes.

- Click Repository > Workspace > Get Latest Version.

## Saving changed items to the Repository (Checking in)

The check in process synchronizes the changes made to the local checked out item with the Repository version by updating the Repository version.

The check in process lets you check in an object, such as a diagram or a model, when you are done working with it.

### Checking in objects

When you check in an object, all object components are checked in as well. You can check in a newly created object, such as a model which you added to a checked-out workspace or you can check in multiple, selected objects simultaneously to the Repository.

The procedure to check in an object into the Repository is basically the same for all object types.

To check in a project, diagram or model

- 1 Save the changes you have made to the workspace; click File > Save.
- 2 Click the object you want to check in or CTRL-click several objects to check in more than one object.
- 3 Right-click and then select Repository > Check In Object(s).
- 4 Enter a comment in the Repository Check In Object(s) dialog and then click OK to start the check-in process.

To check in a workspace

- 1 Save the changes you have made to the workspace; click File > Save.
- 2 Click Repository > Check In Workspace.
- 3 Enter a comment in the Repository Check In Object(s) dialog and then click OK to start the check-in process.

## Checking out Repository items

Checking out write enables items previously added to the Repository, such a workspace, project, diagram or model. The procedure to check out an item from the Repository is the same for all object types.

If you have a workspace checked out, and have checked in some objects, you can check them back out using this procedure.

To check out a project, diagram or model

- 1 Open a Repository workspace; a workspace that was previously added to the Repository.
- 2 Click the item you want to check out or CTRL-click several items to check out more than one.
- 3 Select Repository > Workspace > Check Out Object(s).
- 4 In the Repository Check Out Object(s) dialog, enter a comment if you want to and then click OK to start the check-out process.

**NOTE:** Checked out objects appear in the workspace explorer tree with a check mark in the top left-corner of the object icon.

To check out a workspace

If the active workspace was previously added to or retrieved from the Repository, you can check it out.

- 1 Open a Repository workspace.
- 2 Select Repository > Workspace > Check Out Workspace.
- 3 In the Repository Check Out Workspace dialog, enter a comment if you want to and then click OK.

**NOTE:** Checked out objects, including the workspace, appear in the workspace explorer tree with a check mark in the top left-corner of the object icon.

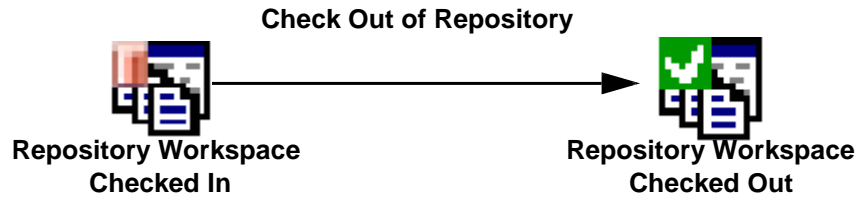

## Discarding changes made to a checked out workspace

If you have checked out a workspace, made changes to it, and want to undo all the changes you made you can undo the check out.

- 1 Log in to the Repository and open the target workspace.
- 2 To discard the changes, click Repository > Workspace > Undo Check Out Workspace.

## Deleting workspaces from the Repository

The Delete Workspace operation lets you delete a workspace from the Repository.

- 1 Log in to the Repository.
- 2 On the Repository toolbar, click the Delete Workspace icon.
- 3 In the Repository Delete Workspace Selection dialog, select the diagram to delete and then click OK.

### Notes

- When you delete a Workspace from the Repository, the local copy of the Workspace is not deleted.
- When deleting a workspace, the Repository leaves workspace data behind and marks it as deleted. If deleted, data is still present in the Repository but visible only when querying the Repository directly, not through ER/Studio BA.

# Using business process modeling notations

A Business Process Model is a visual representation of the flow of activities and their order of performance using a set of graphical elements that use shapes familiar to most modelers and business users. For example, activities are rectangles and decisions are diamonds. The result is having an easy-to-understand mechanism for creating business process models which produce complex business processes.

The following example of a Business Process diagram shows the interaction between a customer applying for a loan and the bank/lender.

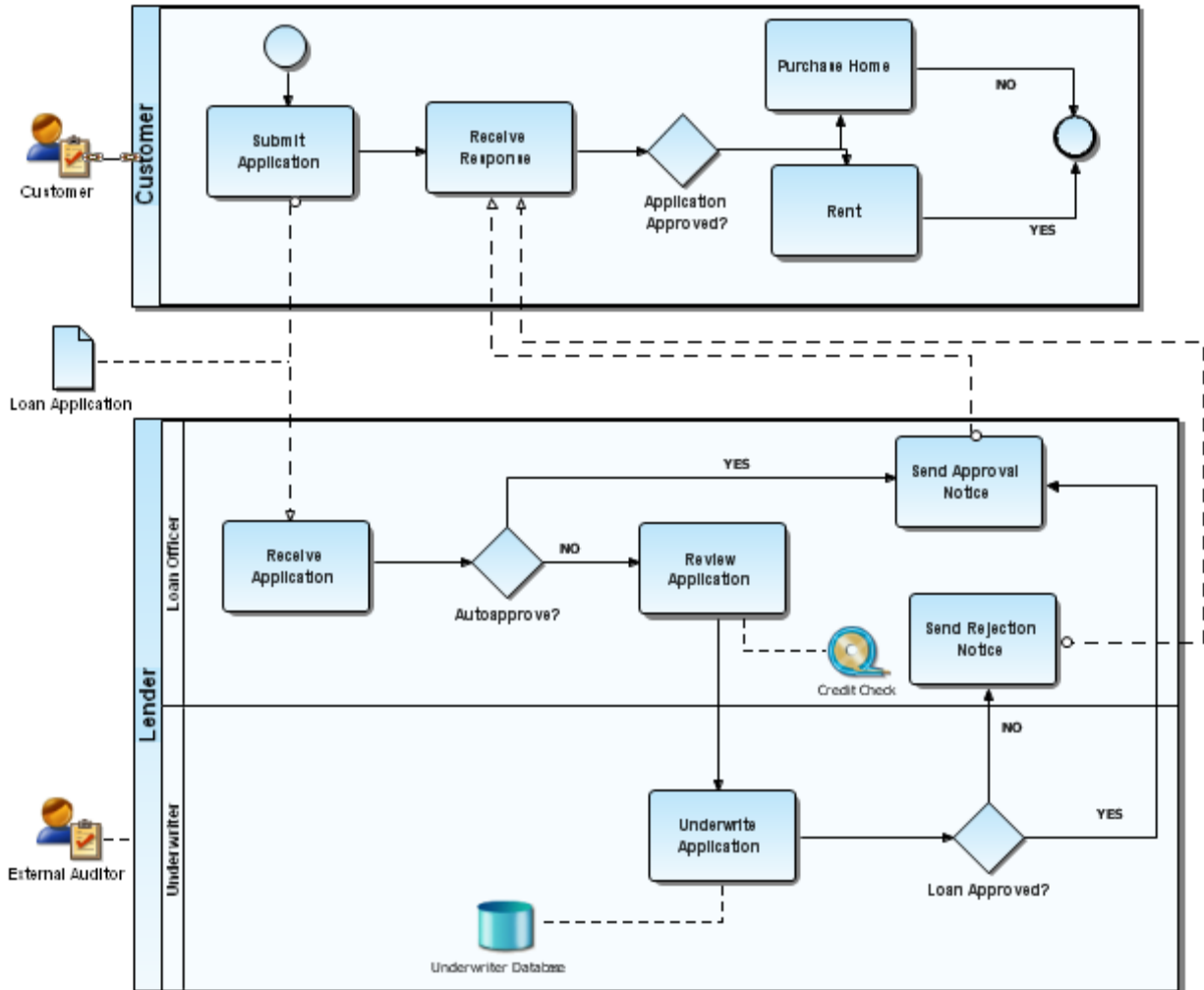



## Business process modeling elements

There are six different categories of Business Process Modeling Notation elements: [Events](#), [Activities](#), [Gateways](#), [Connection Elements](#), [Swimlanes](#), and [Artifacts](#). The following sections discuss all aspects of how you can use them in the application.

ER/Studio BA offers business flow functionality when working with the elements of the diagram. As you place an element in the Diagram View it is validated against the BPMN specification. If a placement or link is invalid, based on the BPMN specification, you will get a warning dialog.

### Validating against BPMN specification



When you [create](#) a new model you can choose to validate the creation of certain elements and flows against the BPMN specifications. The validation checks compliance with the Business Process Modeling Notation specifications. For example, if validation is enabled and you draw a message flow from a start event to a task, you get a dialog stating that this is an invalid relationship. You can select one of three options to resolve the invalid notification:

- Do not allow the relationship to be created.
- Allow the relationship to be created.
- Allow the relationship and do not validate future relationships against the BPMN specification.

**NOTE:** You can set a [preference](#) to turn this feature off or on.

## Events

An event is something that occurs during the course of a business process. These events affect the flow of the process and usually have either a trigger or a result, depending on the event. There are three types of Events based on when they affect the flow: Start, Intermediate, and End. The table below describes the event elements:

Events	Palette Icon	Description
<a href="#">Start Events</a>		Starts a process flow. In terms of a Sequence Flow, the Start Event starts the flow of the Process, so it won't have an incoming Sequence Flow. A Start Event can have one of four <a href="#">Triggers</a> that indicates how the Process starts: Message, Timer, Rule, and Link.
<a href="#">Intermediate Events</a>		Happens during the course of a process event. The available triggers are Cancel, Compensation, Error, Link Message, Rule, and Timer.
<a href="#">End Events</a>		Ends a process flow. The available results are: Cancel, Compensation, Error, Link, Message, and Terminate.

### Start events

A Start Event indicates where a particular process starts. A trigger for a Start Event is designed to show the general mechanism that instantiates that particular process. Use Cases for each trigger type are discussed in the [Using the Start Event](#) topic.

Using the Start event

A process may begin with a start event. This start event can be normal (with no specified trigger) or have one of four different types of triggers. Principle characteristics of a start event are:

- A Start Event is optional.
- If a Process is complex and/or the starting conditions are not obvious, then it is recommended that a Start Event be used.
- If there is an End Event, then there must be at least one Start Event.

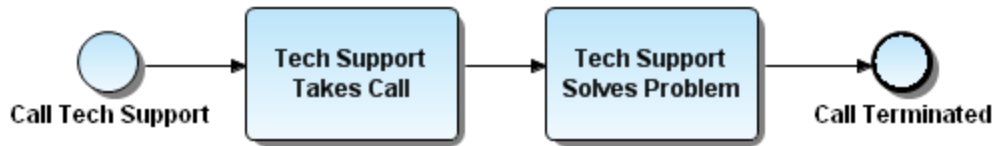

The table below describes the Start Event triggers that you can use to indicate what kind of start event is needed for the diagram:

Element	Palette Icon	Description
Start		This is the normal start event without a specified trigger.
<a href="#">Message</a>		A message arrives from a participant and triggers the start of the Process.
<a href="#">Timer</a>		A specific time-date or a specific cycle (e.g., every Friday at 10:00 a.m.) is set that triggers the start of the Process.
<a href="#">Rule</a>		This type of event is triggered when the conditions for a rule become true.
<a href="#">Link</a>		A mechanism for connecting the end of one Process to the start (or trigger) of another.

Using the Start event message trigger

When a message arrives from a participant it triggers the start of the process. For example a start event could be the receipt of a message that a repair is needed on a computer.

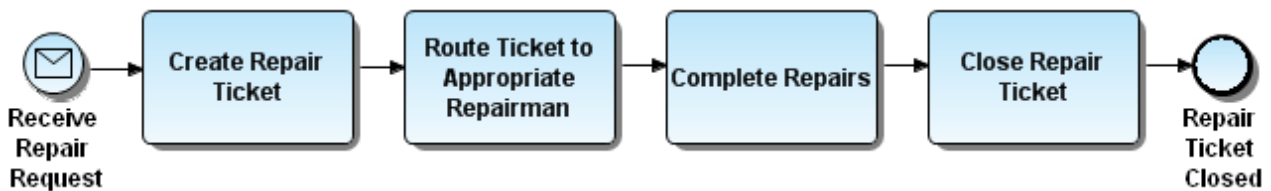

Using the Start event timer trigger

If there is a timer trigger on a start event, the process is started whenever the timer reaches a specific time, date, or cycle. This timer trigger must be received or conditions must be fulfilled before the process can start.

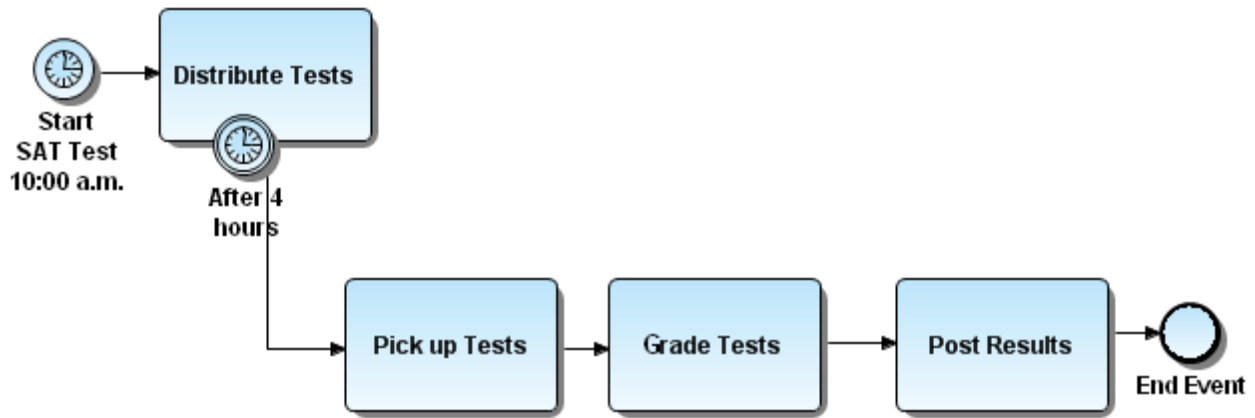

Using the Start event rule trigger

A rule trigger indicates that a signal, sent from another process based on the satisfaction of a rule, should start the current process. This rule trigger must be received or conditions must be fulfilled before the process can start.

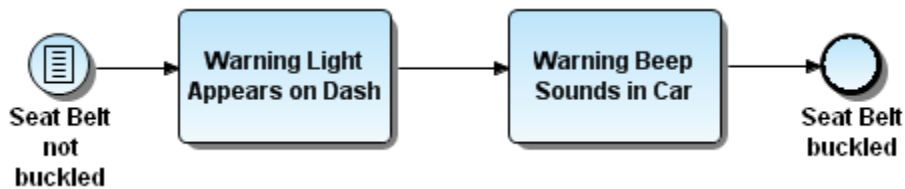



### Using the Start event link trigger

A link trigger indicates that when a signal is sent from another process, the current process should start. This link trigger must be received or conditions must be fulfilled before the process can start.

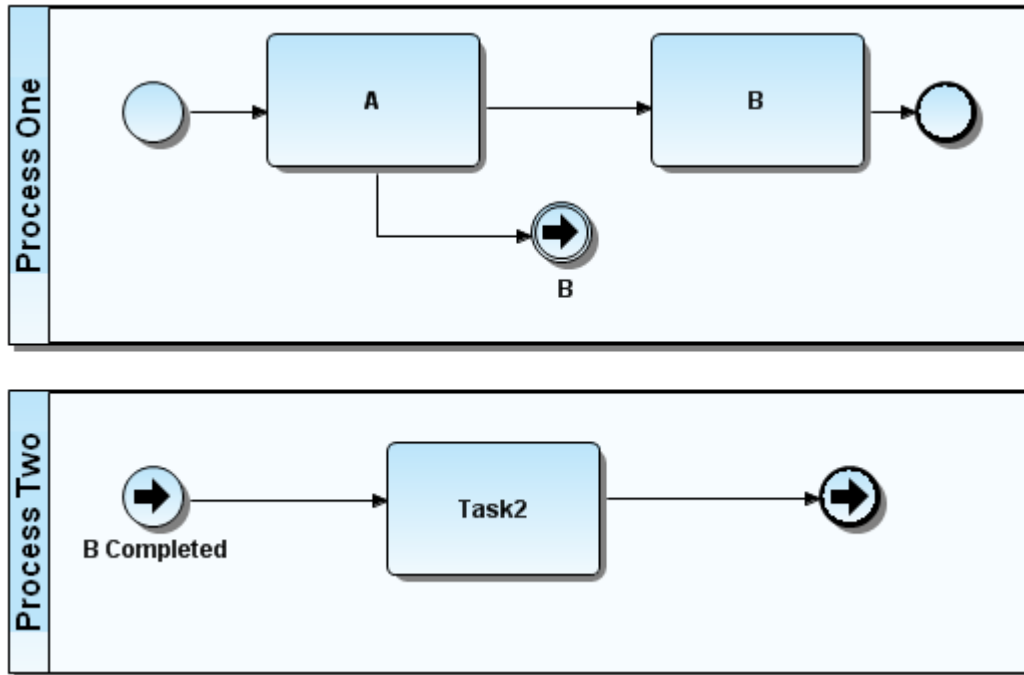

### Intermediate events

An Intermediate Event occurs between a Start Event and an End Event. It is an event that occurs after a Process has been started. It affects the flow of the process but does not directly terminate the process. Intermediate Events can be used to:

- Show where messages are expected or sent within the Process,
- Show delays that are expected within the Process,
- Disrupt the normal flow through exception handling, or
- Show the extra work required for compensation.

An example of one use of Intermediate Events is to represent exception or compensation handling. This is shown by placing an Intermediate Event on the boundary of a Task. The Intermediate Event can attach to any location of the activity boundary and the outgoing Sequence Flow can flow in any direction. Use Cases for each trigger type are discussed in the [Using Intermediate Event Triggers](#) topic.

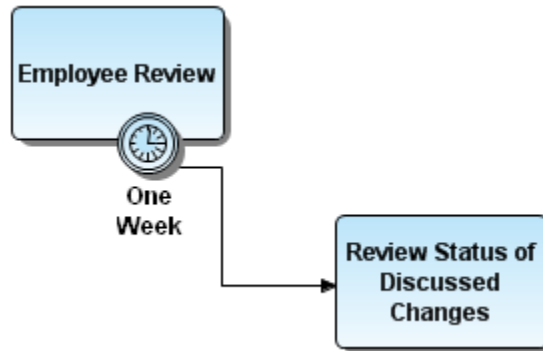

### Using Intermediate event triggers

There are seven Intermediate Event Triggers and the table below displays the palette icon and description for each:

Triggers	Palette Icon	Description
<a href="#">Compensation</a>		Compensation is when activities are invoked that undo an undesirable outcome.
<a href="#">Cancel</a>		This trigger is used within a Transaction Sub-process. This type of event must be attached to the boundary of a Sub- process.
<a href="#">Error</a>		The trigger sets or catches errors. It sets an error if the Event is part of a Normal Flow. It reacts to a named error when attached to the boundary of an activity.
<a href="#">Link</a>		Connects an End Event of one Process to an Intermediate Event in another Process.
<a href="#">Message</a>		A message arrives from a participant and triggers an Event. The Process then continues if it is waiting for a message, or changes the flow for exception handling.
<a href="#">Rule</a>		This trigger is only used for exception handling. This event is triggered when a Rule becomes True. A Rule is an expression that evaluates some Process data.
<a href="#">Timer</a>		A specific time-date or cycle is set that triggers an Event. It can act as a delay mechanism if used within the main flow. If used for exception handling, it changes the Normal Flow into an Exception Flow.

### Using the Compensation Intermediate event

A Compensation Association occurs outside the Normal Flow of the Process and is based upon an event (a Cancel Intermediate Event) that is triggered through the failure of a Transaction or a Compensation Event. The target of the Compensation Association must be marked as a Compensation Activity.

#### Compensation Intermediate event use case

The following is a use case for how a compensation intermediate event would be implemented.

A travel agent books a flight for a corporate client. The normal flow for the business process occurs as follows:

- There is a start event (message) when a corporate client calls to book a flight.
- The travel agent makes the necessary arrangements (a Book Flight task) and the flight is booked (end event).
- However, the corporate client calls back and has to cancel. This is handled by an intermediate compensation event which “interrupts” the normal sequence flow to an outgoing directed association “flow” (compensation association). There is a rollback of travel arrangements (compensation activity) where the travel agent cancels the flight (a Cancel Flight task).

**NOTE:** Note that the Book Flight task cannot be compensated by a Cancel Flight task until the Book Flight task has been completed. The end result of this compensation is that the corporate client card is restored to an initial balance of \$0.00, unless there are cancellation fees.

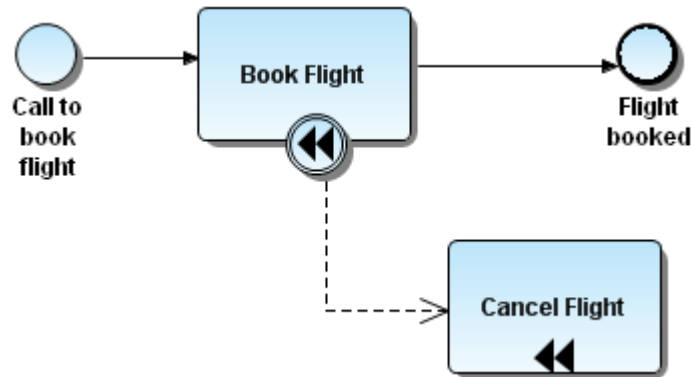



The tasks in the above scenario could be replaced by a Book Flight sub-process (e.g., if there are several steps to booking a flight you may decide to create a sub-process, either embedded or independent) and a Cancel Flight sub-process. These would become compensated sub-processes if the intermediate compensation event is “invoked”.

#### Placing an Intermediate Compensation event

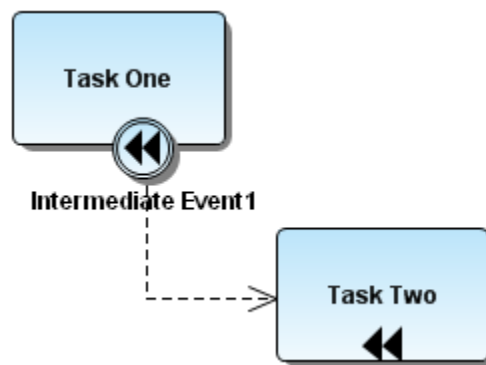
- 1 From the Business Process Objects Palette, click the drop-down arrow on the Intermediate Event node.
- 2 Select the Compensation Intermediate Event icon () and click the task that contains the event you want to compensate (or roll back).
- 3 With the automatic connection feature you can then immediately draw an association link to the task containing the information for the roll back. A compensation marker is then automatically placed on the second task.



4 Press ESC to exit the multi-drop mode.

**NOTE:** The cursor changes from  to .

Using the Cancel Intermediate event

A cancel trigger can be attached to an intermediate event. The resulting event type is always attached to the boundary of a transaction action. It acts as a mechanism to interrupt this transaction action.

In the following example, when buying concert tickets online, if the payment succeeds the tickets are purchased. If the tickets are not paid, the payment action triggers a cancel action. This cancellation action also results in the Cancel Tickets action and the process ends.

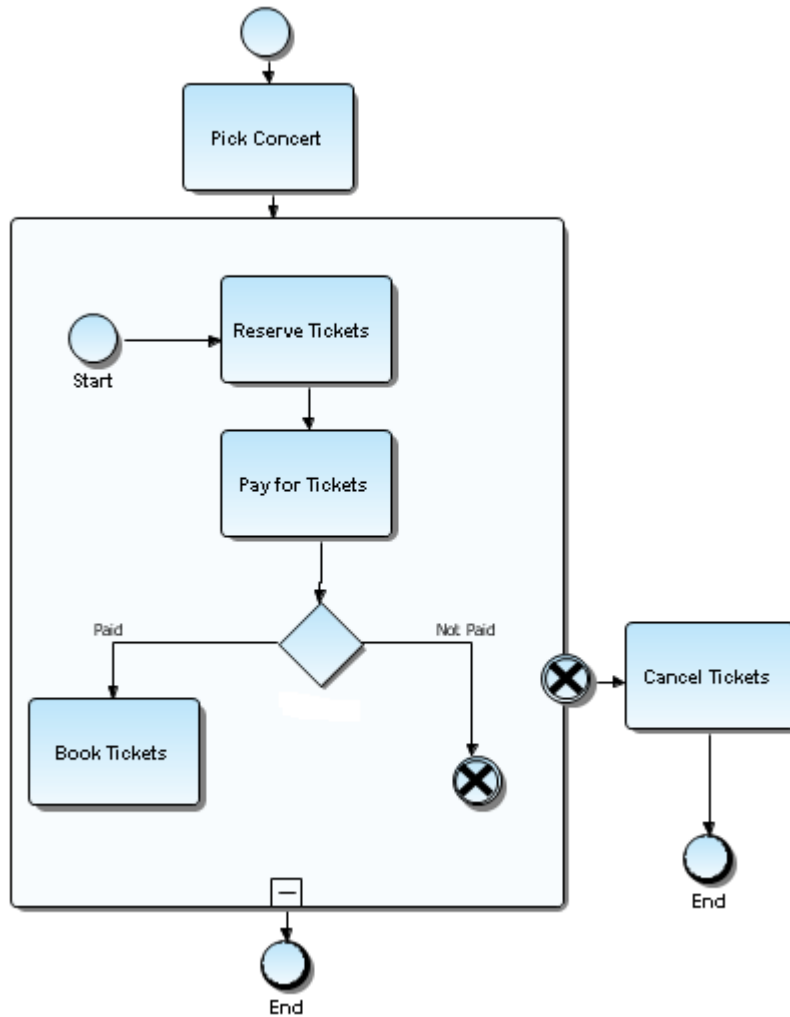

Using the Error Intermediate event

The Process involving an error intermediate event begins with the receipt of a request for an online purchase. After a credit card verification, an online purchase is made. The purchase may take more than one attempt before it is successful. After the purchase is confirmed, a reply is sent.

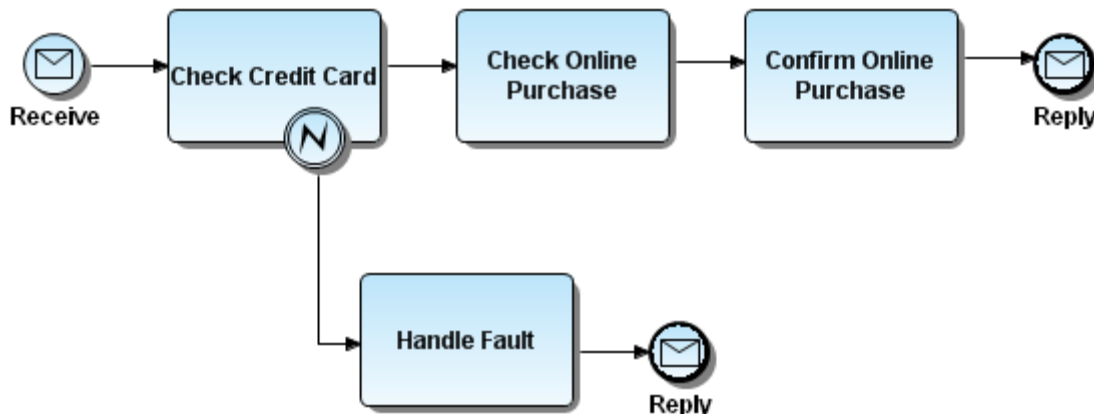

Using the Link Intermediate event

A link is a mechanism for connecting the end event of one process flow to the start event of another process flow. A link intermediate event can be used as an “[Off-Page Connector](#)” or as a “[Go To object](#).”

**CAUTION:** If your off-page connectors need to be named the same, you must use the Off-page Connector icon instead of the Link Intermediate Event object. You cannot have two Link Intermediate Events with the same name on a diagram.

Using the link as an off-page connector

If a process model extends beyond the length of one printed page you can use a Link Intermediate Event to show how Sequence Flow connections extend across the page breaks. In the sample below, a pair of Link Intermediate Events is used; one at the end of page one and the second at the beginning of page two. This Event is named and has an incoming Sequence Flow and no outgoing Sequence Flow. The second Link Event shares the same name, and has an outgoing Sequence Flow and no incoming Sequence Flow.

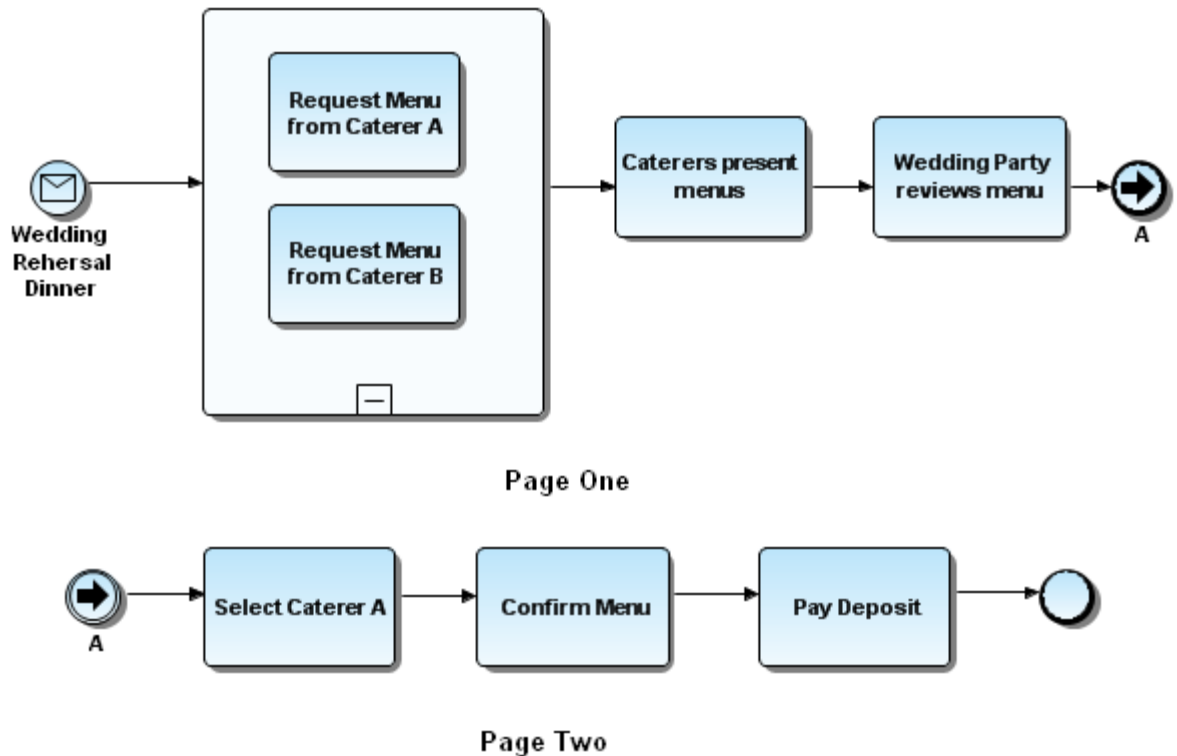

Using link as a “Go To” object

Link Intermediate Events can also be used as “Go To” objects. They work the same as [Off-Page Connectors](#), but can be used on the same page or across multiple pages. They reduce the length of Sequence Flow lines which may be hard to follow or trace. When it is used as a Go To object, the process continues as if the Sequence Flow had directly connected the two objects. The following diagram shows the “Go To” links used in place of a long Sequence Flow link from the first gateway to the Close Order task, thus simplifying the look of the diagram.

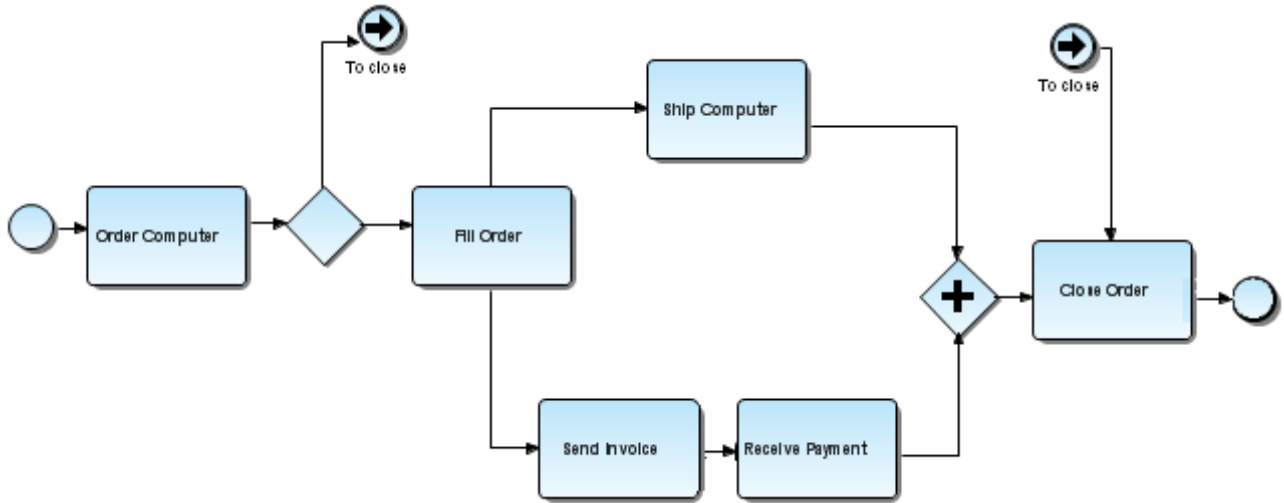

Using the Message Intermediate event

When placed within the diagram, a message event specifies that the process is waiting for a message in order to resume its activity. There are usually flow links before and/or after this event.



Using the Rule Intermediate event

The Rule Intermediate Event is triggered when the conditions for a rule become true during the execution of the process. This trigger can occur in the normal flow of the process or it can be attached to the boundary of an action or it can also be used in an event-based decision pattern.

The rule intermediate event is used for exception handling when a named rule becomes true. Because the rule intermediate event is only used for exception handling, it has to be placed on the edge of an activity, as it creates an exception flow.

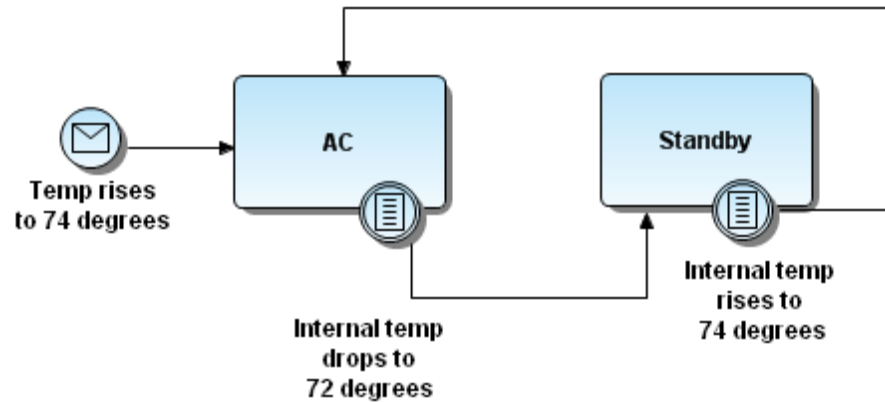

### Using the Timer Intermediate event

When placed on an activity, the timer event represents something that can occur during the execution of an activity. There is usually a link (flow or message) going out of the event to specify the action to perform if such an event occurs.

- 1 Click the Timer Intermediate Event icon on the Business Process Modeling Notation palette.
- 2 Click the task onto which you want to place the event. When you do this, the event then becomes part of the activity.

The following example shows a timer event during an activity execution.

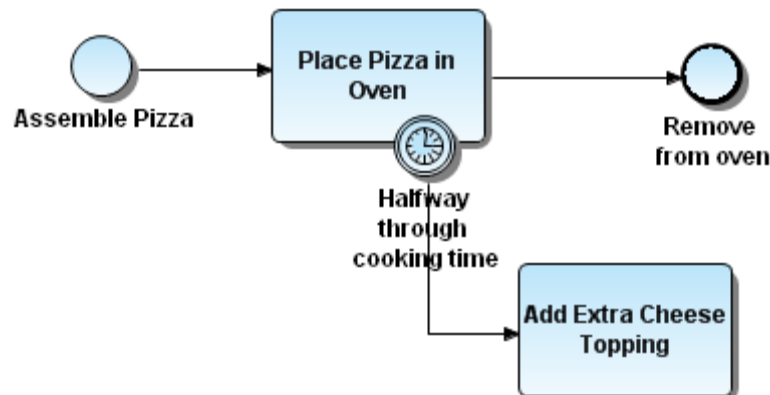



## End events

The End Event indicates where a process ends. You can define the consequences or results of reaching an End Event. The example below shows a simple online credit card application with an end message denoting that a message was generated at the end of a process.

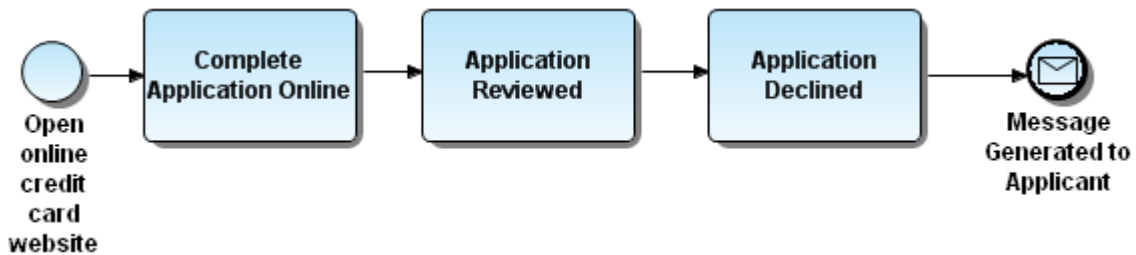

A use case for each End Event trigger is discussed in the [Using the End Event](#) topic.

### Using the End event

If there is a start event, then there must be an end event. There are different results or consequences that happen when you reach an end result.

The table below displays the palette icon and description for each End Event result:

Result	Palette Icon	Description
<a href="#">Compensation</a>		This End Event indicates that a Compensation is necessary. The Compensation identifier triggers an Intermediate Event when the Process is rolling back.
<a href="#">Cancel</a>		The type of End Event is used within a Transaction Sub- process. It indicates that the Transaction should be canceled and triggers a Cancel Intermediate Event attached to the Sub-process boundary. It also indicates that a Transaction Protocol Cancel message should be sent to any Entities involved in the Transaction.
<a href="#">Error</a>		A named Error should be generated. This Error is caught by an Intermediate Event within the Event Context.
<a href="#">Link</a>		A Link is a mechanism for connecting the end of one process to the start of another.
<a href="#">Message</a>		A message is sent to a participant at the conclusion of the process.
<a href="#">Terminate</a>		All activities in the Process should be ended immediately. The Process is ended without compensation or event handling.



### Using the Compensation End event

This type of End Event indicates a Compensation is necessary. The Compensation identifier triggers an Intermediate Event when the Process is rolling back.

At the end of a trip, a person checks out of a hotel using express checkout. Their bill has been delivered during the night and the person finds a charge for an extra day. Prior to departing the hotel the person goes to the checkout desk and asks for a refund. The clerk refunds the client's credit card, rolling back the process by reimbursing the person. As express checkout was the end of the process (end event). A compensate end event with outgoing directed association "flow" (compensation association) to the original charge activity is necessary to rollback charges to the person's credit card.

### Placing a Compensation End event

Take the following steps to place a compensation end event:

1. From the Business Process Objects Palette click the drop-down arrow on the End Event node .
2. Select the Compensation End Event icon () and click the task that contains the event you want to compensate for (or roll back).
3. Press ESC to exit the multi-drop mode.

**NOTE:** The cursor changes from  to .

### Using the Cancel End event

This End Event can only be used within a Transaction Sub-process and causes the cancellation of that Process. The process is ended with normal event handling. In the following example, the client did not pay for his tickets so the process was cancelled.

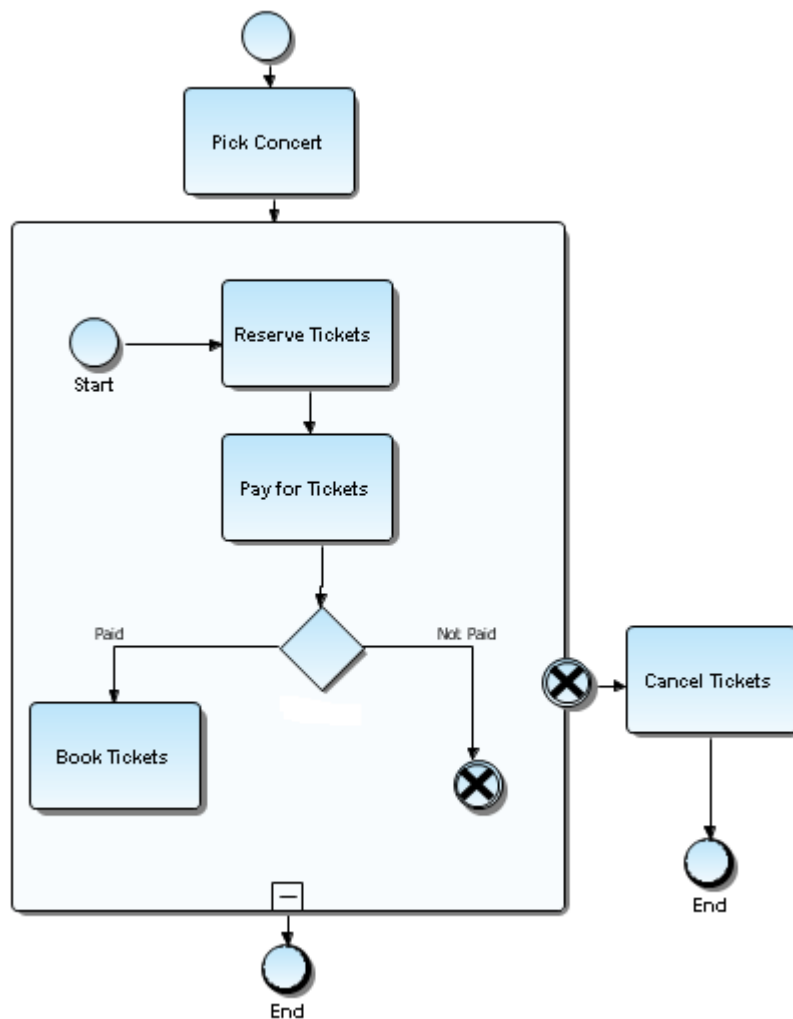

Using the Error End event

The Error End Event indicates that a named Error should be generated. The following diagram shows the process for a consumer who wants to make a purchase with a credit card. If the credit card is invalid the process goes to an error end event. The desired behavior is a valid credit card which takes the flow to a task called "Charge Credit Card" and then to an end event.

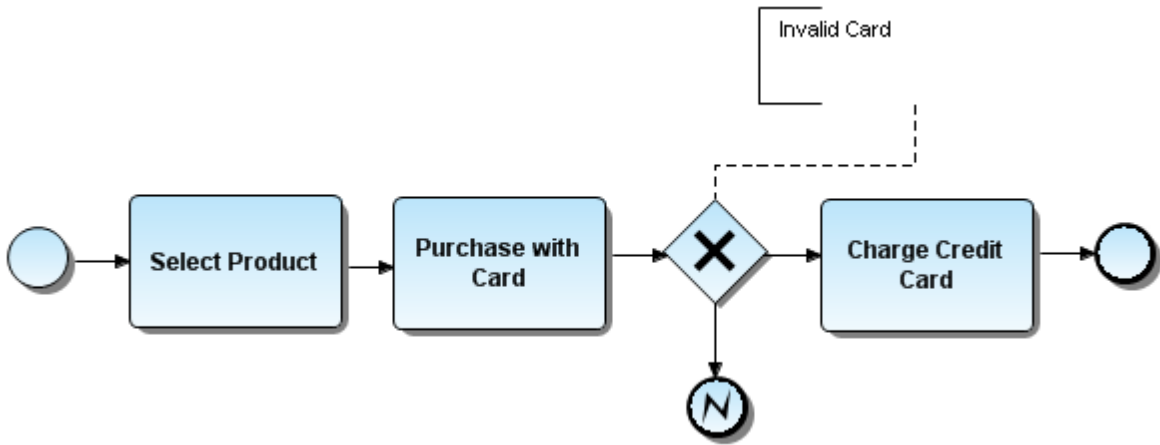

Using the Link End event

There are points within a process where it is important to know whether a specific milestone has been met. The process model must be able to identify and react to the milestone.

The example below shows how information can be passed from one part of a diagram to another part. In the diagram, paperwork must be completed in one sub-process before the paperwork in another sub-process can start. A Link End Event that follows the Payment Received Task is used to trigger a corresponding Link Start Event that precedes the first task in the second sub-process.

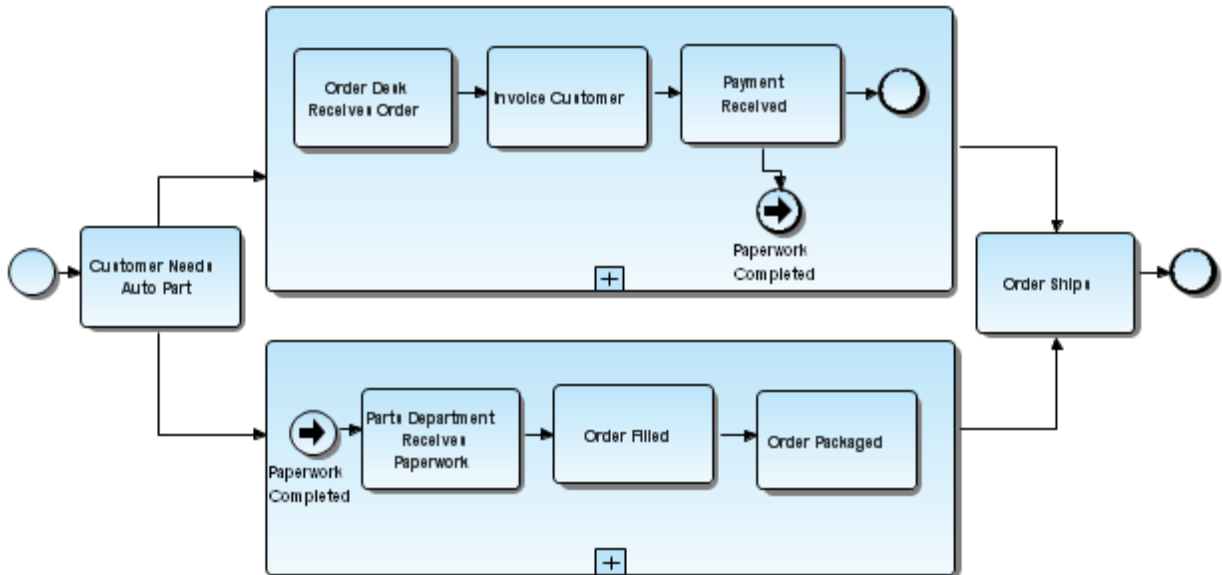

Using the Message End event

A Message End Event finishes a process and sends a message to a participant.

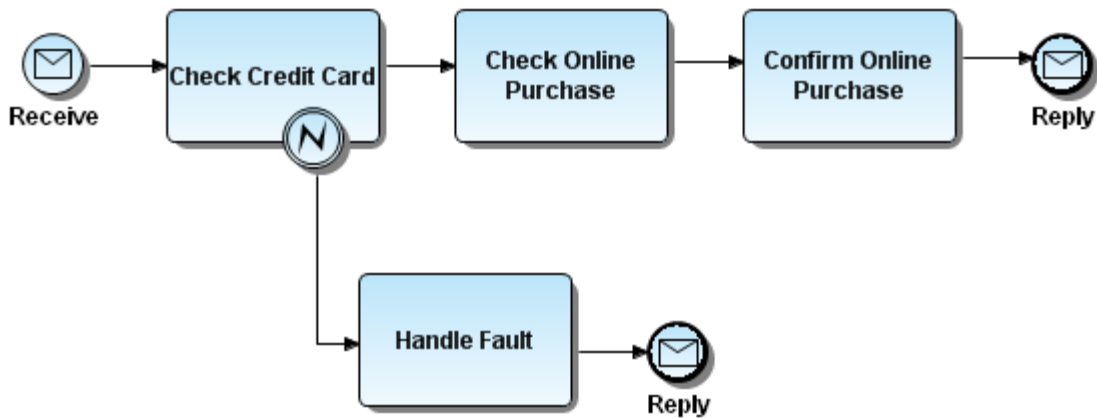

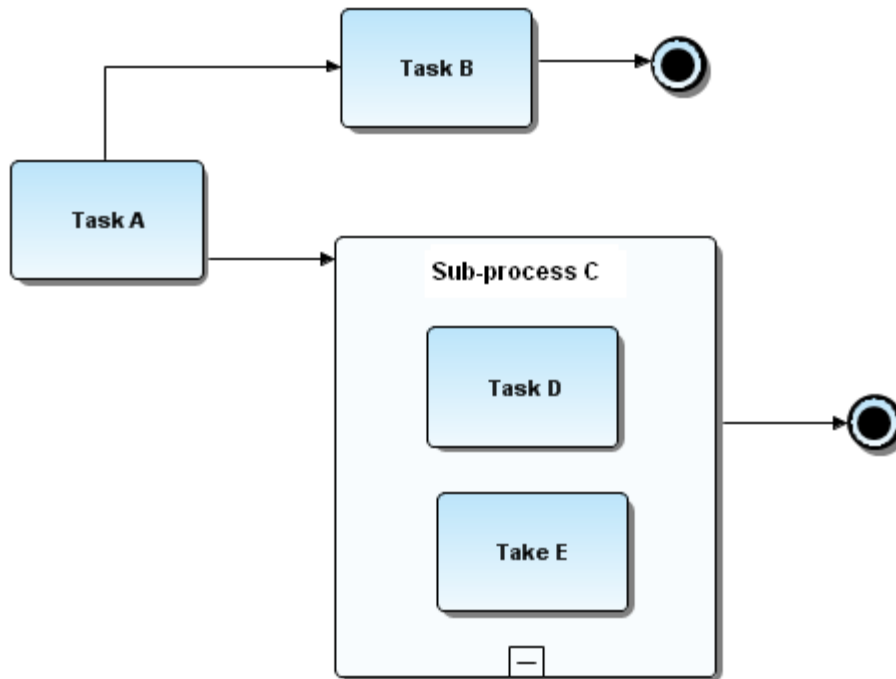

Using the Terminate End event

The Terminate End Event indicates that all activities in the Process should be ended immediately even if there are tasks that have not started or are still active. This includes all instances of Multi-Instances. The Process is ended without compensation or event handling. The Terminate End Event symbol is placed where the cancellation should be signaled.



## Activities

An activity is work that a company performs and can be atomic or non-atomic (compound). The types of activities that are a part of a Process Model are: Process, Sub-process, and Task. Processes must be contained within a Pool. The table below displays the icon for each element with a description.

Element	Palette Icon	Description
<a href="#">Task</a>		This is an activity that is performed within a business process.
<a href="#">Sub-processes</a>		
<a href="#">Independent Sub-process</a>		An independent Sub-process element is an activity within a Process that calls to another process that exists within a business process definition diagram.
<a href="#">Embedded Sub-process</a>		An Embedded (or nested) Sub-process is an activity that contains other activities (a Process). The Process within the Process is dependent on the parent Process for instigation and has visibility to the parent's global data. No mapping of data is required.

### Task

A task is an activity that is included within a Process. You use a Task when the work in the Process is not broken down to a finer level of Process Model detail. Generally, an end-user and/or an application are used to perform the Task when it is executed. The tasks can have different behaviors, however these behaviors are not indicated by any graphical indicators.

To set a type for a task:

- 1 Right-click on the tasks to open the [Properties](#) View.
- 2 On the General tab, click the drop-down arrow in the Task type text box and select the type from the list. The additional properties that you can set change depending on the type selected. For example if you select "Service", you can set the "In Message", "Out Message" and "Implementation" properties.



**NOTE:** You can [convert](#) a task to an Independent Sub-process or Embedded Sub-process.

There are seven different task types:

Task Type	Description
Service	A Service Task provides some sort of service such as a Web service or an automated application.
Receive	A Receive task waits for a message to arrive from an external participant. Once the message has been received, the Task is completed. A Receive Task is often used to start a Process.

Task Type	Description
Send	A Send Task sends a message to an external participant. Once the message has been sent, the Task is completed.
User	This is a workflow task performed by a human with the assistance of a software application. It is scheduled through a task list manager of some sort.
Script	When the Task is ready to start, the engine executes a script written in a language that a business process engine can interpret. When the script is completed, the Task is also completed.
Manual	A Manual Task is expected to be performed without the aid of any business process execution engine or any application.
Reference	The Reference Task refers to another activity that has been defined with the exact same behavior.

The table below describes the two types of markers for a Task:

Element	Icon	Description
Loop		The attributes of Tasks and Sub-processes determine if they are repeated or performed once. There are two types of loops: Standard and Multi-Instance. The looping indicator is displayed at the bottom-center of the activity.
Parallel Multiple Instance		This refers to multiple instances of the activities. Activities that are Parallel Multi-Instance have a parallel marker placed in the bottom center of the activity.

### Converting a task

When you right-click on a task you can select the *Convert to* command on the shortcut menu. You have two conversion options: Embedded Sub-process and Independent Sub-process. This command is useful if you want to break down a task into smaller parts or add more details/subtasks.

For example, in your design process you determined that your task will be “Load New Software on Computer”. You then decide you want to make the task more detailed requiring a sub-process where you can create tasks for each detail: (1) shop for best price on software; (2) purchase software; (3) verify compatibility; and (4) load software.

When you convert a task the following characteristics apply:

- A converted element is placed on the diagram in the same place as the task.
- The converted task is renamed with the new element’s type default name. For example, if you are converting to an embedded sub-process, the converted element is named “embedded sub-process”.
- When connecting objects are anchored to the task, they are not moved and after the conversion and retain their connection point.
- You will get a warning dialog if the conversion breaks any validation rules.
- Object formatting attributes are retained after the conversion.
- Elements retain their same size after the conversion.

## Sub-processes

A Sub-process extends the set of common activity attributes. The two different sub-processes are [embedded](#) and [independent](#).

The Sub-process can be in a collapsed view that hides its details or it can be an expanded view that shows its details within the view of the Process in which it is contained. In the collapsed form, the Sub-process element uses a marker to distinguish it as a sub-process, rather than a Task. The first graphic shows a collapsed sub-process. The second graphic shows the Embedded Sub-process expanded.

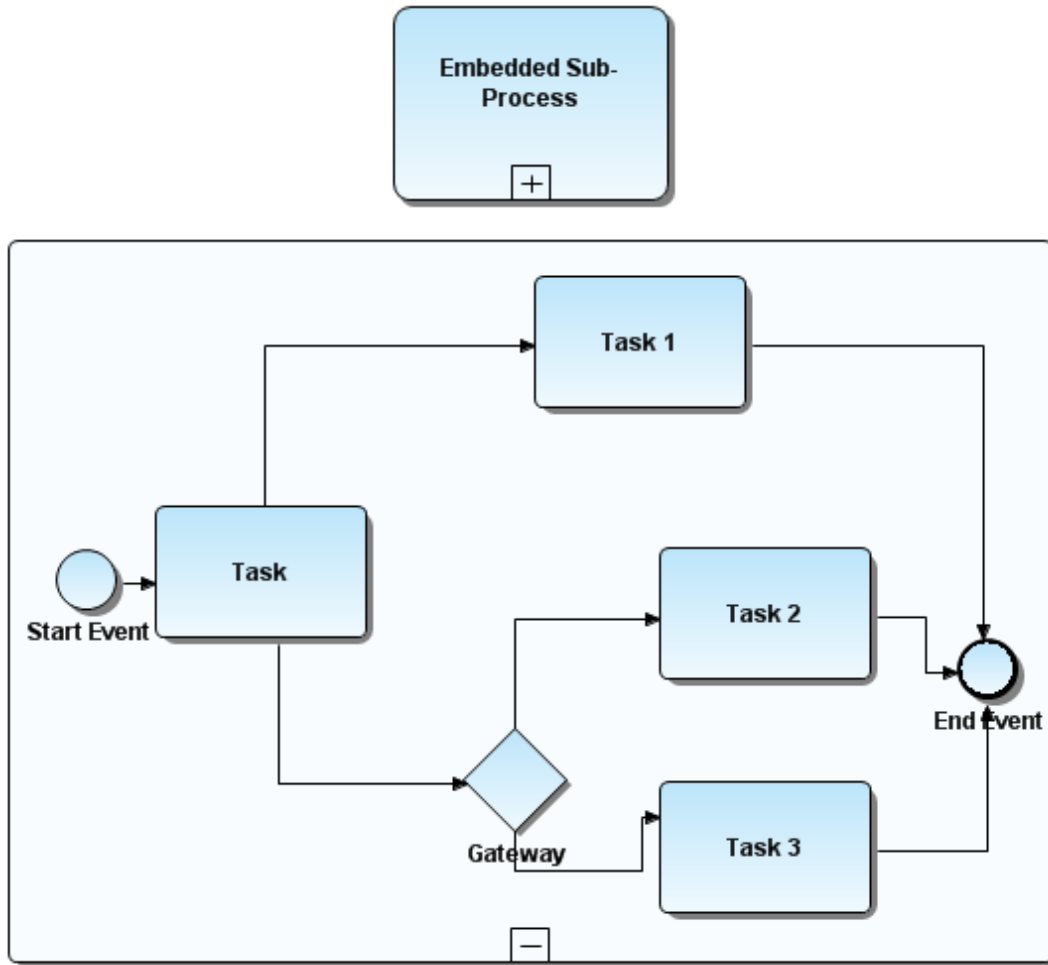





### Embedded sub-process

An Embedded (or nested) Sub-process element is an activity containing other activities (a Process). The Process within the Process depends on the parent Process for instigation and has visibility to the parent's global data. No mapping of data is required. The elements within the Embedded Sub-process, being dependent on their parent, do not have all the features of a full Business Process Diagram, such as Pools and Lanes. So an expanded view of the Embedded Sub-process only contains Events, Activities, connecting elements, and Artifacts.

**NOTE:** When an Embedded Subprocess is placed in the Diagram View, the label appears vertically centered. Once you add a child element, the label is then relocated to the top center of the Embedded Subprocess.

There are six types of standard markers for Embedded Sub-processes, including the Standard marker. The (Collapsed) Sub-process Marker, can be combined with four other markers: a Loop Marker or a Parallel Marker, a Compensation Marker, and an Ad Hoc Marker. A collapsed sub-process may have one to three of these other markers, in all combinations except that the Loop and Multiple Instance cannot be shown at the same time.

The table below briefly describes each embedded sub-process:

Element	Palette Icon	Description
Standard Embedded Sub-process		A Sub-process hides its flow details. The Collapsed Sub-process element uses a marker to distinguish it as a Sub- process, rather than a Task. The marker is a small square with a plus sign (+) inside.
Ad Hoc Embedded Sub-process		An Ad Hoc Process is a group of activities that have no pre-definable sequence relationships. Activities within the Process are disconnected from each other. During execution of the Process, any one or more of the activities may be active and they can be performed in almost any order or frequency.
Loop Embedded Sub-process		The attributes of Tasks and Sub- processes will determine if they are repeated or performed once. There are two types of loops: Standard and Multi- Instance. A small looping indicator is displayed at the bottom- center of the activity.
Multiple Instance Embedded Sub-process		The attributes of Tasks and Sub- processes determine if they are repeated or performed once. A small parallel indicator is displayed at the bottom-center of the activity.
Transaction Embedded Sub-process		A Sub-process, either collapsed or expanded, can be set as being a Transaction, which has a special behavior that is controlled through a transaction protocol (such as BTP or WS-Transaction). The boundary of the activity is double-lined to indicate that it is a Transaction.

**NOTE:** To select multiple elements in the Embedded Subprocess, hold down the ALT key to invoke the [marquee](#) cursor.

### Independent s ub-process





An Independent Sub-process element is an activity within a Process that “calls” to another Process that exists within a separate diagram. The Process that is called is not dependent on the Independent Sub-process’ parent Process for instantiation or global data. The called Process is instantiated when called, but it can be instantiated by other Independent Sub-process elements (in other diagrams) or by a message from an external source. The Independent Sub-process element may pass data to/from the called Processes.

When an Independent Sub-process (ISP) is created (either in the Model View tree or dropped in the Diagram view), a new diagram with an associated pool and lane are created at the model level. The default name of the ISP will be the default name of the Independent Sub-process element (e.g. Independent Sub-Process).

There are six types of standard markers for Independent Sub-processes, including the Standard marker. The (Collapsed) Sub-process Marker, can be combined with four other markers: a Loop Marker or a Parallel Marker, a Compensation Marker, and an Ad Hoc Marker. A collapsed sub-process may have one to three of these other markers, in all combinations except that the Loop and Multiple Instance cannot be shown at the same time.



The table below briefly describes each independent sub-process:

Element	Palette Icon	Description
Standard Independent Sub-process		A Sub-process hides its flow details. The Collapsed Sub-process element uses a marker to distinguish it as a sub-process, rather than a Task. The marker is a small square with a plus sign (+) inside.
Ad Hoc Independent Sub-process		An Ad Hoc Process is a group of activities that have no pre-definable sequence relationships.  Activities within the Process are disconnected from each other. During execution of the Process, any one or more of the activities may be active and they can be performed in almost any order or frequency.
Loop Independent Sub-process		The attributes of Tasks and Sub-processes will determine if they are repeated or performed once. There are two types of loops: Standard and Multi- Instance. A small looping indicator is displayed at the bottom-center of the activity.
Multiple Instance Independent Sub-process		The attributes of Tasks and Sub-processes determine if they are repeated or performed once. A small parallel indicator is displayed at the bottom-center of the activity.
Transaction Independent Sub-process		A sub-process, either collapsed or expanded, can be set as being a Transaction, which has a special behavior that is controlled through a transaction protocol (such as BTP or WS-Transaction). The activity has a double border to indicate that it is a Transaction.

## Gateways

A Gateway controls the divergence and convergence of the Sequence Flow. It determines branching, forking, merging, and joining of paths. Basically it is a question that is asked at a point in the flow. This question has a defined set of alternative answers.

Element	Palette Icon	Description
Gateway		This symbol displays decisions, merges, forks, and joins in the process flow. It controls how Sequence Flows interact as they converge and diverge within a process. You can set the <a href="#">Gateway Control Types</a> of a gateway and change the logic specified by it. There are two different ways to set the Gateway's control types: from the <a href="#">palette</a> , or on the <a href="#">Model View</a> .

### Placing gateways using the palette

1. Click Gateway in the Business Process Objects Palette to expand the node.
2. Click the gateway with the control type you want to use from the expanded node.
3. Click once in the Diagram View and the selected gateway is placed in the diagram.

**NOTE:** Notice that the selected gateway also appears in the Model View tree with the appropriate icon designating the control type.





### Placing gateways using the Model view

1. Right-click the lane name where you want to place the gateway.
2. Select New and then select Gateway from the list of available elements and a gateway node is placed in the Model View tree.
3. Double-click the gateway node and the Gateway Properties View opens.
4. In the Type list box select the control type you want to use from the type drop-down list and click OK. The gateway node icon changes to represent your control type.

**NOTE:** You can then drag the gateway node from the Model View tree on to the Diagram View.

## Gateway control types

You can set control types for gateways. A control type changes the logic and also the symbol it represents. The table below lists all the available control types for a gateway.

Control Type	Icon	Explanation
<a href="#">Data-Based</a>		These are the most common gateways used. A data token traverses the Process Flow arriving at the gateway. It can only go out on one flow. This control type is represented by either a diamond with an "x" in the middle or blank diamond shape.
<a href="#">Event-Based</a>		<b>Decision:</b> This represents a branching point where the alternatives are based on an event occurring at that point. <b>Merge:</b> The exclusive merge models data-based or event-based merges. Only one of the many inputs is chosen as the output.
<a href="#">Inclusive</a>		<b>Decision:</b> One or more of the outgoing Sequence Flows may be taken. A default flow must be specified at this point, there cannot be zero output flows. <b>Merge:</b> A process flow continues when it receives the first input signal from the input Sequence Flow. If other signals arrive after that, they are not used.
<a href="#">Complex</a>		<b>Decision:</b> This expression determines which output flow is taken from multiple Sequence Flow names. <b>Merge:</b> You specify a complex flow condition referencing incoming Sequence Flow names or process data coming into a gateway. This expression determines when the task starts.
<a href="#">Parallel</a>		<b>Fork:</b> All Sequence Flows out of this gateway are taken. <b>Join:</b> This gate must receive input signals from all input Sequence Flows. The process flow does not continue until it receives all signals.

### Using data-based gateways

The Data-Based Decision is a branching point where the alternatives are based on conditional expressions contained within the outgoing Sequence Flow. Only one of the Alternatives is chosen.

In the following graphic, there are three alternative tasks that may be performed. The decision on which task is performed is based on the Boolean expression contained in the Condition Expression attribute of the outgoing Sequence Flow of the Gateway. The expression uses the values of process data to determine which path is taken.

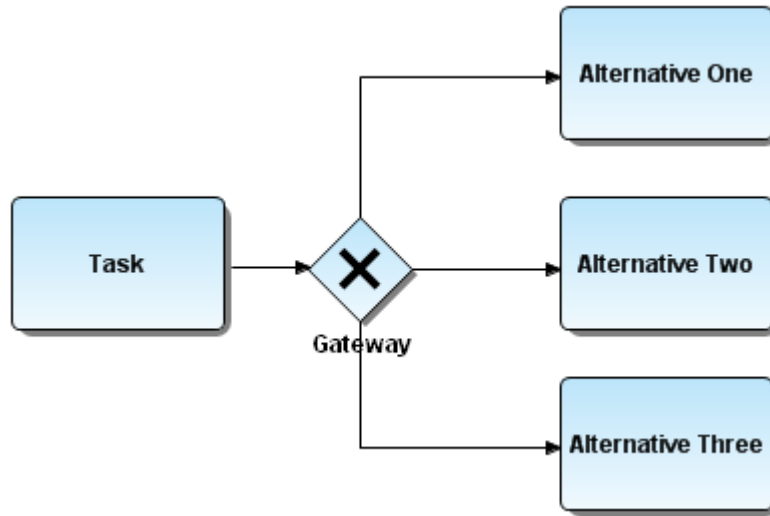

### Using event-based gateways

An Event-Based decision represents a branching point where the alternatives are based on an event that occurs at that point in the Process. The specific Event, such as the receipt of a Message or a Timer event, determines which of the paths will be taken. Only one of the Alternatives is chosen. The following example shows an event-based gateway using message events.

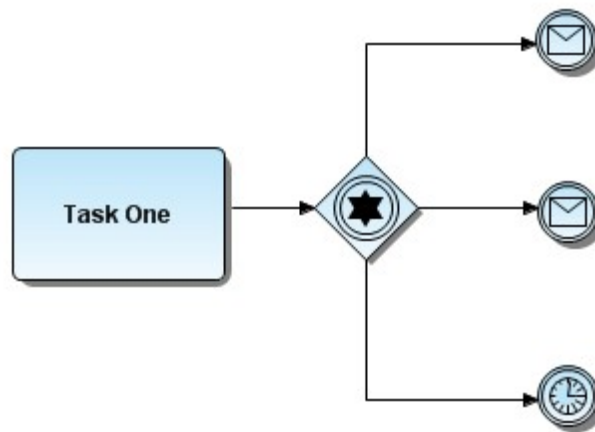



### Using inclusive gateways

Inclusive gateways provide more than one possible outcome. There is usually a corresponding merging inclusive gateway. The following example shows a number of chapters in a book that may be included in a book.

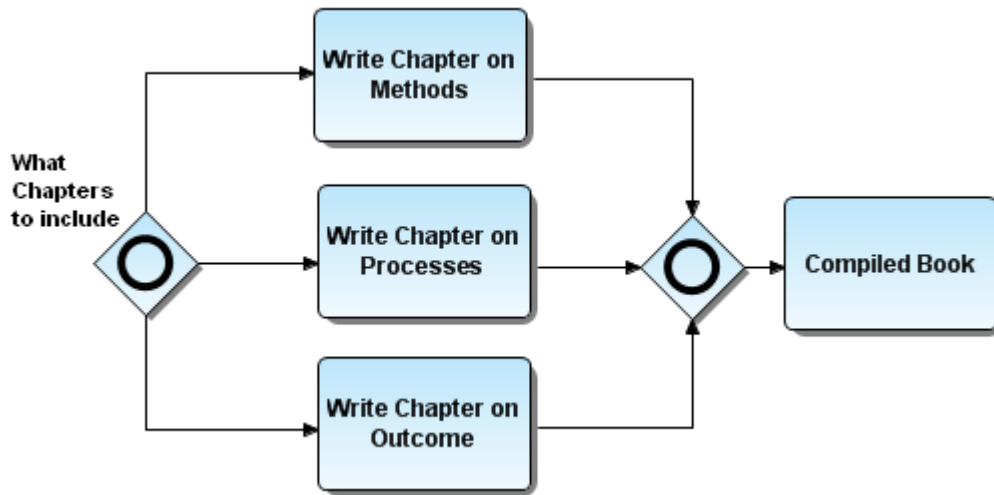

### Using complex gateways

A Complex Gateway is used to handle situations that are not easily handled through the other types of Gateways. Complex Gateways can also be used to combine a set of linked simple Gateways into a single, more compact situation. Complex behavior can be defined for both the merging and splitting behavior.

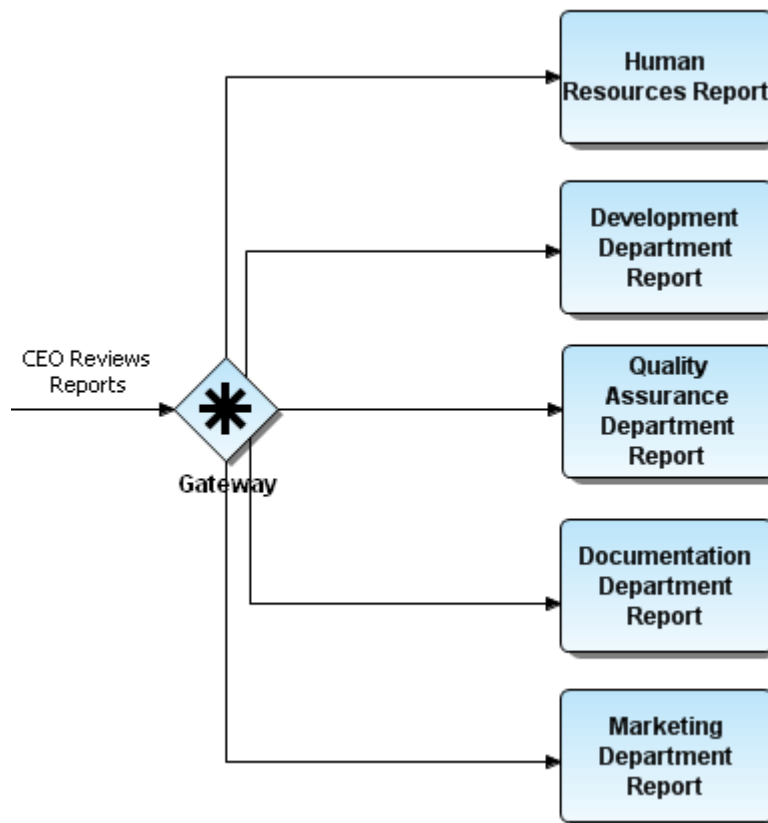

### Using parallel gateways

Parallel Gateways are places in the Process where multiple parallel paths are defined. Events on parallel outcome paths execute simultaneously and independently of each other. You can create a decision point that directs the process flow down multiple flows so activities are executed in parallel (instead of executing in sequence). These flows can then be reunited into a single flow to complete the task. The process execution waits until the last task in each parallel flow has been completed. The following example shows two parallel gateways. The task following the second gateway is executed only after all the parallel paths are completed.

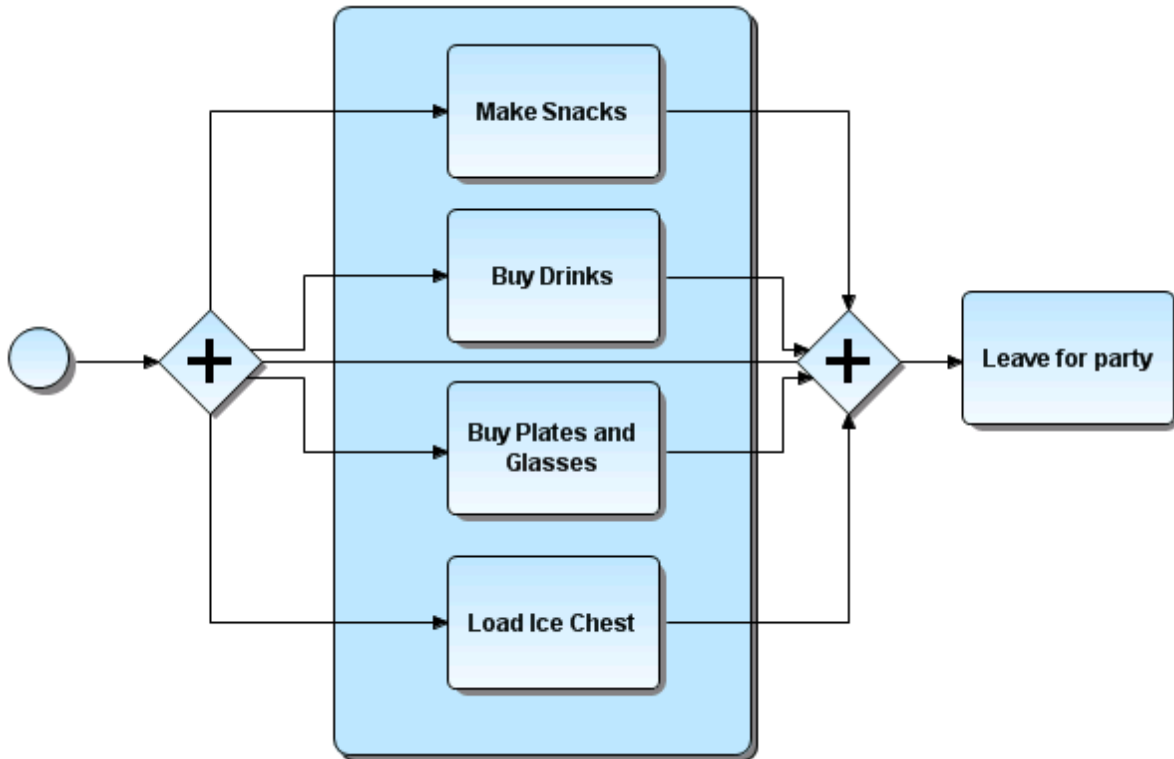

### Connection elements

There are three ways of connecting Events and Activities to each other or to other information: Sequence Flow, Message Flow, and an Association. You can gain access to the Property View for each connection element by double-clicking the relationship element in the diagram.

The table below describes the link types displayed on the Business Process Objects Palette:

Connection elements	Palette Icon	Description
<a href="#">Sequence Flow</a>		A sequence flow shows the sequence of processes in an organization. You can use the sequence flow lines to connect events, processes, and gateways in pools or lanes. The <a href="#">Sequence Flow</a> has three different designations that can be set using the <a href="#">Sequence Flow Property View</a> . Double-click the Sequence Flow to open the Sequence Flow Properties dialog.
<a href="#">Message Flow</a>		Shows the model order of processes between organizations (i.e. between pools).
<a href="#">Association</a>		An Association is used to associate information and artifacts with events and activities.

## Sequence flow

A Sequence Flow shows the sequence of processes in an organization or department. When you use pools or lanes in your diagram, you use Sequence Flow lines to connect events, activities, and gateways within the pools or lanes. The Sequence Flow is represented as a line with a filled-in arrow head.

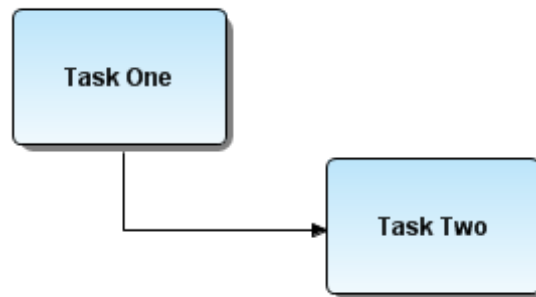

There are five different types of sequence flows and you can [change](#) a sequence flow type:

Type	Flow_Type_Examples	Description
Normal Flow		This is the flow originating from a Start Event and continues through activities via alternative and parallel paths until ending at an End Event.
Uncontrolled Flow		This flow is not affected by any conditions and does not pass through a Gateway, for example a single Sequence Flow connecting two activities. An Uncontrolled Flow can also apply to multiple Sequence Flows converging or diverging from an activity. For each uncontrolled Sequence Flow, a "Token" flows from the source element to the target element.
Conditional Flow		A conditional flow is evaluated at runtime to determine whether or not the flow is used. If the conditional flow is outgoing from an activity, then the Sequence Flow has a mini-diamond at the beginning of the line. If the conditional flow is outgoing from a Gateway, then the line does not have the diamond.
Default Flow		For Data-Based Exclusive Decisions or Inclusive Decisions, one type of flow is the Default Condition flow. This flow is used only if all other outgoing conditional flows are not true at runtime. These Sequence Flows have a diagonal slash added to the beginning of the line. You would add a Default Conditional Flow marker to a Sequence Flow for two types of decision: Data-based Exclusive and Inclusive Decisions. This flow is used only if all the other outgoing conditional flows are not true at runtime.
Exception Flow		Exception Flows occur outside the normal flow of the Process and it is based upon an Intermediate Event that occurs during the performance of the Process.



### Changing the type of flow marker

1. Double-click the Sequence Flow that you want to change to a default flow marker and the Properties dialog opens.
2. Click the drop-down arrow in the Condition Type box and select Default from the list.
3. Click OK. The Properties dialog closes and the marker is added to the sequence flow.

### Message flow

Message Flows are used to show the flow of messages between two participants that are prepared to send and receive them. A Message Flow can connect directly to the boundary of a pool or it can cross the boundary of a pool and connect to an object within that pool. Also, if there is an Expanded Sub-Process in one of the Pools, then the Message Flow can be connected to either the boundary of the Sub-Process or to objects within the Sub-Process. The following example shows a Message Flow across the boundary of a pool.

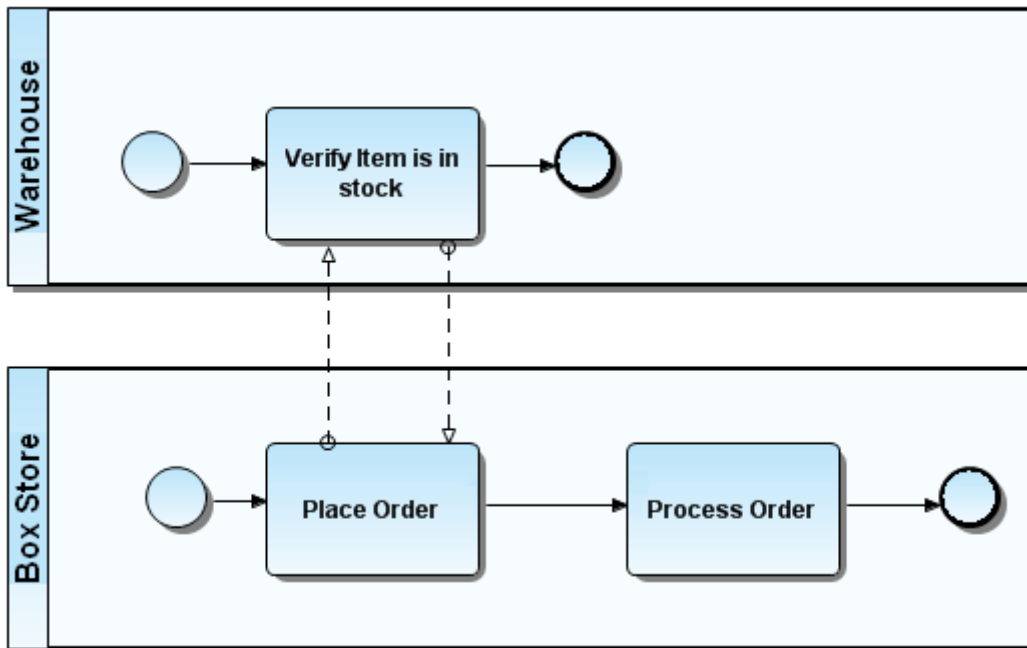

### Association

An Association is used to associate information with events and activities. It can be used to associate reference objects, external data objects, shapes, and activities with textual information. You can also use an Association to associate Data Objects with other objects.

There are four different Associations available:

- Association ( " " )
- Association to Target ( " " )
- Association From Target ( " " )
- Association To/From Target ( " " )

The selection you make is reflected on the beginning and ending indicator on the Association. You can set global preferences for all the line display options in the [Preferences](#).

The example below shows an Association connecting a Data Object with two tasks.

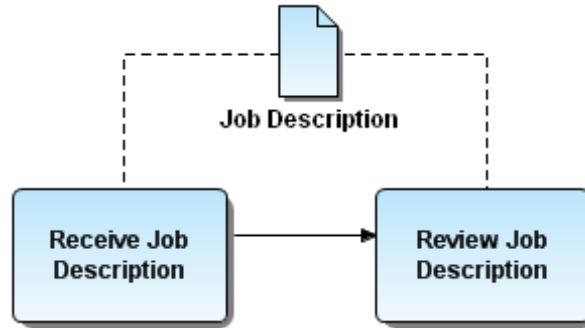





## Swimlanes

You can group primary modeling elements by using swimlanes which consist of pools and lanes. A Pool represents a participant in a process. It also acts as a graphical container for partitioning a set of activities from other Pools, usually in the context of Business-to-Business (B2B) situations.

A Lane is a subpartition within a Pool and extends the entire length of the Pool. Lanes are used to organize and categorize activities.

The table below describes the types accessible from the Business Process Objects Palette:

Swimlanes	Palette Icon	Description
<a href="#">Pools</a> (Horizontal)	 	<p><b>Horizontal Pool:</b> This pool is drawn as a rectangular region placed horizontally. A lane is a subpartition within a pool and extends the entire length of the pool. A pool represents an organization, function, application, class, or an entity.</p> <p><b>Vertical Pool:</b> This pool is drawn as a rectangular region placed vertically. It has the same characteristics as the horizontal pool.</p>
<a href="#">Lanes</a>		Lanes organize and categorize activities. When you place a process in a pool or lane you specify who is doing what. If you place an event in a lane you specify where that event occurs. When you place a gateway in a lane you specify where a decision is made or who makes it.
<a href="#">Nested Lane</a>		You can insert lanes within lanes.

Pools

A Pool represents a participant in a [Processes](#). It is also called a “swimlane” and is a graphical container for partitioning a set of activities from other pools. The activities within separate Pools are considered self-contained Processes. When this is true, the Sequence Flow may not cross the boundary of a Pool. A Message Flow is the mechanism to show the communication between two participants, and is the connection used between Pools.

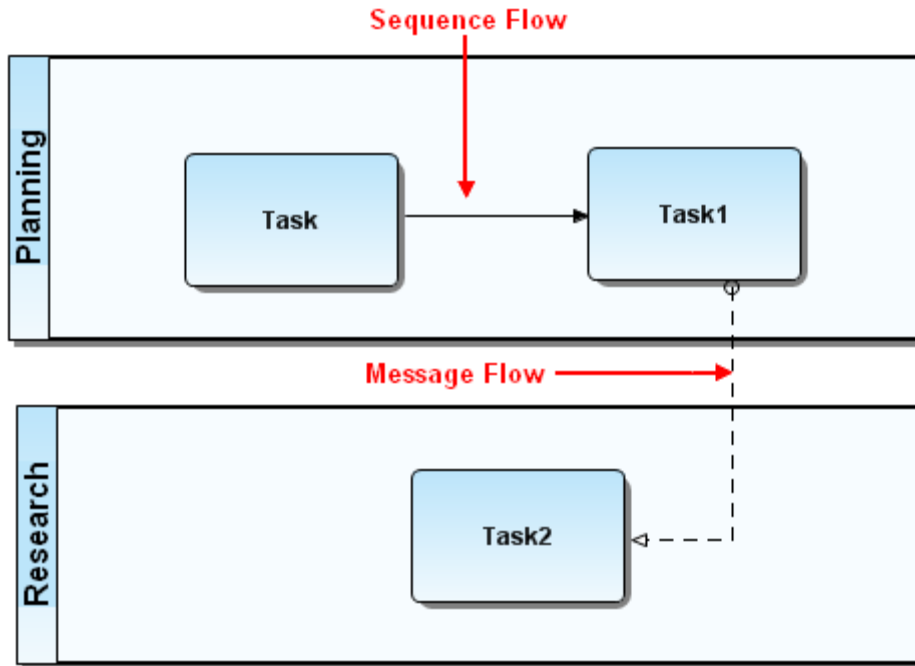

When you create a pool in ER/Studio BA, a lane is created at the same time. If [Validation](#) is turned when you create the project, the lane is not labeled.

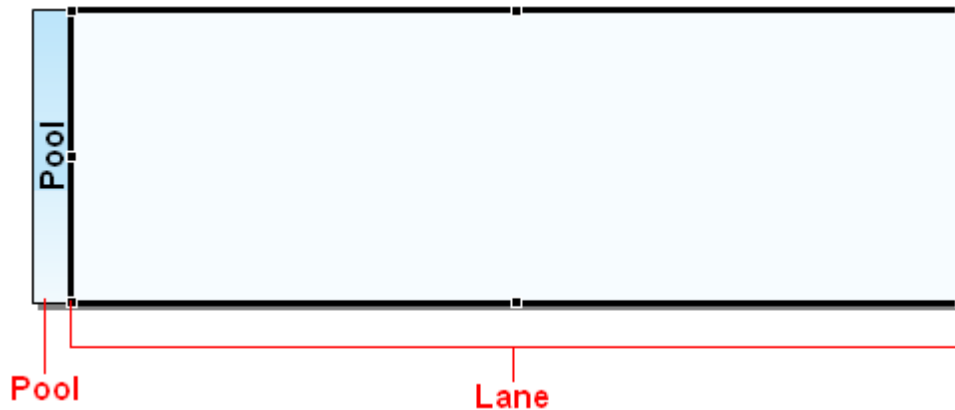

A pool can be shown as a “White Box” with all the details of the activity in the pool exposed. A “Black Box” hides all of a pool’s activities. No Sequence Flow is associated with a black box, but a Message Flow can attach to its boundaries. The default display for a pool is as a white box.

**NOTE:** When all lanes are removed from a pool it becomes a black box pool. The pool header label remains, but the lane area is hidden.

### Processes

When creating a pool and lane, visible or invisible, when elements are dropped in the lane (or diagram), the elements appear at the same level as the lane in the Model View.

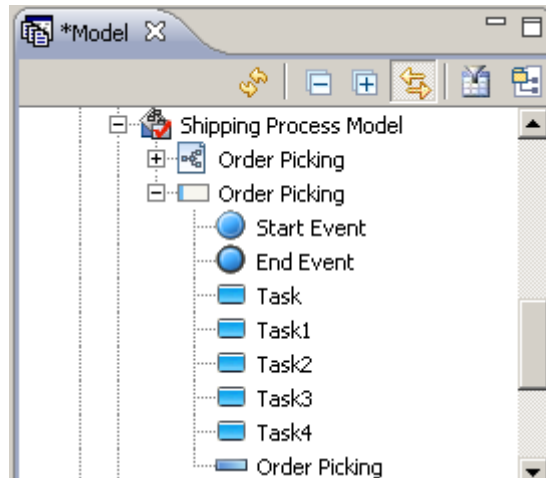

However, in the Business Process Modeling Notation specification, all elements in a pool are owned by a process. This process is not shown by default in the Model View tree. However, it can be displayed by setting the [Processes](#) Preference.

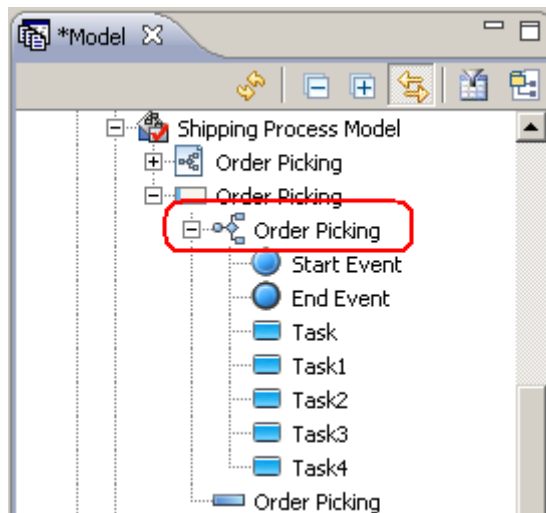

### Lanes

A Lane is a subpartition within a pool. Lanes organize and categorize activities. Lanes are often used to separate the activities associated with a specific company function or role. A Sequence Flow may cross the boundaries of Lanes within a Pool, but a Message Flow may not be used between events and activities in Lanes of the same Pool or between the lanes of the same Pool.

When you click a lane in a pool, selection handles appear on the selected lane.

You have many ways to insert lanes in pools. You can also resize lanes, create nested lanes, reorder lanes in pools, delete lanes from pools, and remove lanes from pools.

**NOTE:** To select multiple elements in the Lane, hold down the ALT key to invoke the [marquee](#) cursor.

### Inserting lanes in pools

In ER/Studio BA when you create a pool, one lane is also created in that pool. There are several different ways to insert additional lanes in a pool: (1) from the [diagram shortcut menu](#); (2) from the [palette](#); (3) from the [Model View tree](#); and (4) using the [insert key](#). You can also create [nested lanes](#).

#### Inserting lanes in a pool using the Diagram shortcut menu

1. Right-click in the pool header and the shortcut menu opens.
2. Click Insert Lane and if it is a horizontal pool, it is inserted at the bottom. If it is a vertical pool, it is inserted on the right.

#### Inserting lanes by an existing lane using the Diagram shortcut menu

1. Right-click in a lane and the shortcut menu opens.
2. Click Insert Lane. If it is a horizontal pool you can choose to insert the new lane above or below the selected lane. If it is a vertical pool you can choose to insert the new lane to the left or right of the selected lane.

#### Inserting lanes from the Business Process Objects palette

1. From the Palette, click the Lane icon (  ).
2. When you place the cursor in a pool or lane an indicator appears. This thick double-line indicates where the lane will be dropped (above or below selected lane). In the following example the new lane is inserted below the BPPool lane.

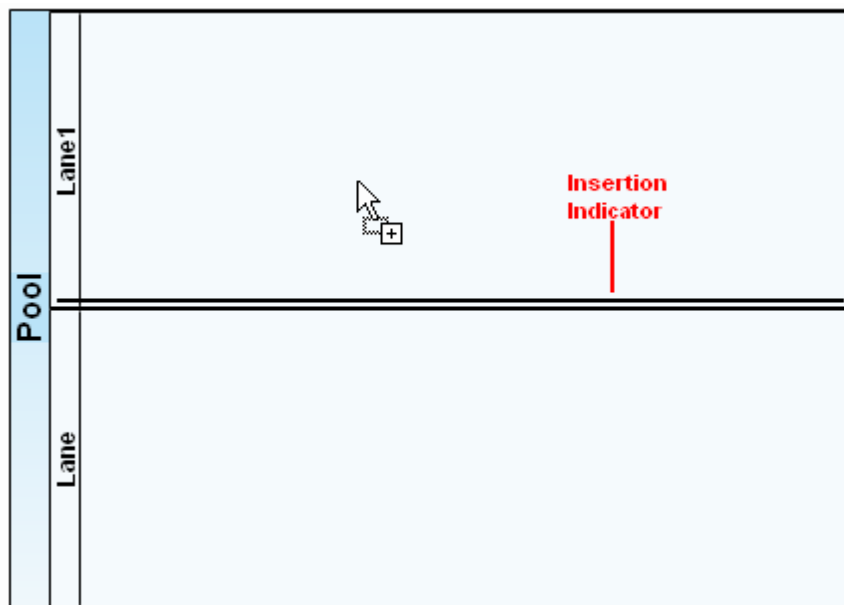

### Inserting a lane from pool node in the Model view

You can create a lane in a pool from the pool node in the Model View tree.

1. Right-click the pool node in the Model View tree.
2. Select New > Lane. If it is a horizontal pool, a lane is added to the bottom of the pool. If it is a vertical pool, the lane is added to the right of the pool.

You can also create a lane from a lane node in the Model View tree.

1. Right-click the lane node in the Model View tree and select New > Lane.
2. Then select either Above or Below from the pull-right menu. If it is a horizontal pool, a lane is either added above or below the selected lane, or to the left or right of the selected lane.

**NOTE:** In the Model View tree hierarchy, the lanes are always placed above or below the selected lane based on your choice of location.

### Inserting a lane using the Insert key

1. Select a pool or lane.
2. Press the Insert (INS) key.
  - o If pool is selected (in a diagram), and you press the Insert key, the new lane is added to the bottom or to the right.
  - o If a lane is selected (in a diagram), and you press the Insert key, the new lane is added to the top (above) or to the left.

### Creating a nested lane

You have two different ways to create a nested lane:

- Right-click in an existing lane and select Insert Lane > Within Lane.
- Select the Nested Lane icon (  ) from the Business Process Objects palette and click once in an existing lane.

### Resizing lanes



You can resize lanes by selecting the selected lane's border on the diagram and dragging. The resizing function has the following characteristics/restrictions:

- You can set a [preference](#) so the pool size will adjust when resizing lanes.
- You can resize individual lanes.
- When sizing the pool the minimum size limits on all of the lanes are respected (i.e. the minimum size of the pool is the sum of the minimum size of the child lanes.)
- When showing/reshowing hidden lanes, the size of existing lanes within a given diagram does not change. Newly added lanes are the default lane size and can increase the size of the pool by the size of the lane, as required.



### Resizing a lane

1. Select the lane to be resized.
2. Place the cursor on the top or bottom (horizontal pools) or the left or right (vertical pools) lane selector indicators.

**NOTE:** Note that the cursor changes from the move cursor (  ) to the resize cursor (  )

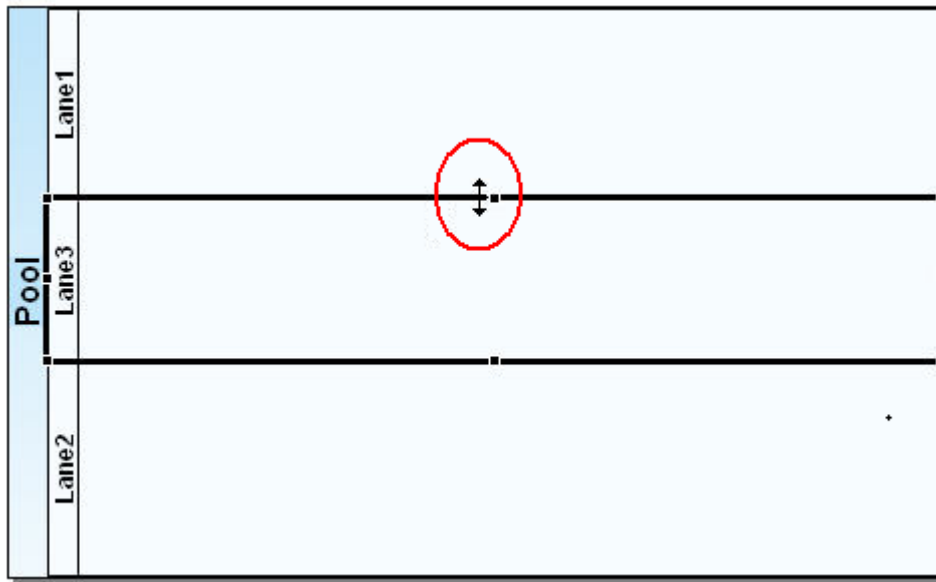

3. Drag the cursor to resize the lane or pool to the desired size.

### Reordering lanes in pools

You can reorder the lanes in a pool either in the [diagram](#) or in the [Model View tree](#).

**NOTE:** You can only reorder lanes within its own pool. You cannot move lanes from one pool to another.

### Reordering lanes in a diagram

There are two different ways to order lanes in the diagram: (1) dragging the lane to a new position within the pool; or (2) using the Move Lane dialog.



Using the drag method

1. Click the lane or lanes you want to move. The selected lane now has selection handles.  
**NOTE:** Select multiple lanes by pressing Ctrl and then clicking the lanes you want to move.
2. While holding down the mouse button, drag the lane its new position. Notice that the order of the lanes in the Model View tree reflects the change you just made in the diagram.

When you are reordering the lanes in a pool an indicator appears. This thick line indicates where the lane will be dropped (above or below selected lane). In the following example the new lane is placed above the lane labeled THREE.

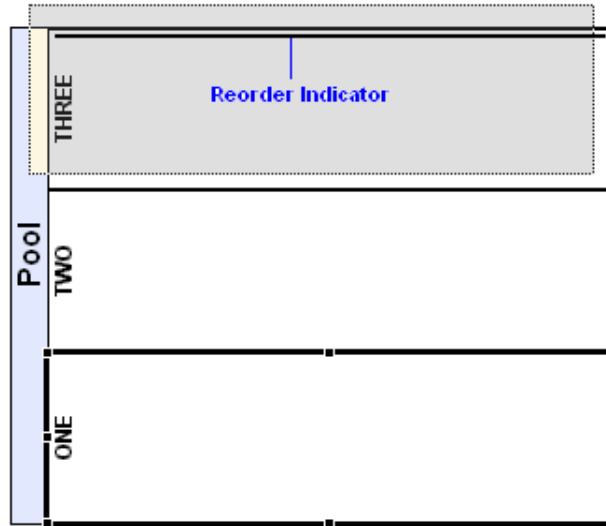

Using the Move Lane dialog

1. In the diagram select the lane or lanes you want to reorder.  
**NOTE:** Select multiple lanes by pressing Ctrl and clicking the lanes.
2. Right-click the selected lane(s) and click Move Lane on the shortcut menu. The Move Lane dialog appears.

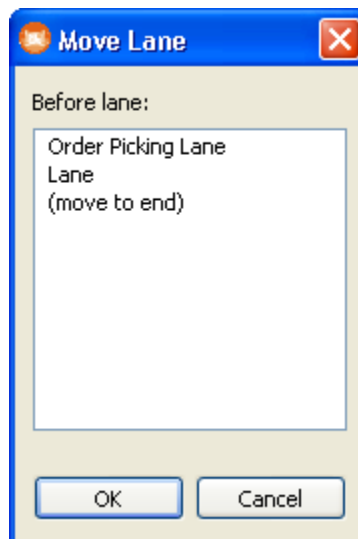

3. From the list of lanes, select the lane you want to move the lane before and click OK.

### Reordering lanes in the Model view tree

There are two different ways to order lanes in the Model View tree: (1) dragging the lane to a new position within the tree; or (2) using the Move Lane dialog.

Using the Drag method:

1. Select the lane or lanes you want to reorder.
 

**NOTE:** Select multiple lanes by pressing Ctrl and then clicking the lanes you want to move.
2. Drag the lane or lanes to its new position in the tree. A horizontal indicator displays where the moved lane will be inserted. In the example below, lane ONE is moved to just below lane THREE.

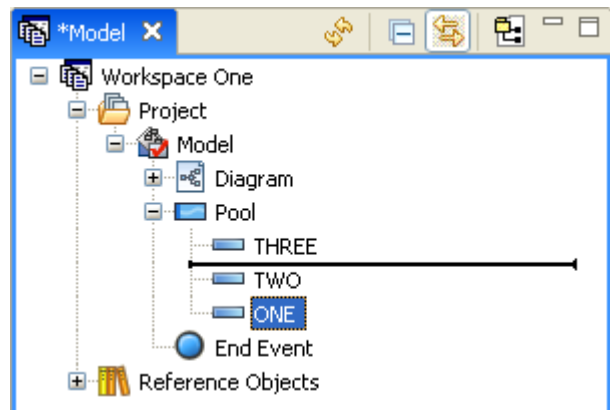

Using the Move Lane dialog

1. In the Model View tree select the lane or lanes you want to reorder.
 

**NOTE:** Select multiple lanes by pressing CTRL and clicking the lanes.
2. Right-click the selected lane(s) and click Move Lane on the shortcut menu. The Move Lane dialog opens.

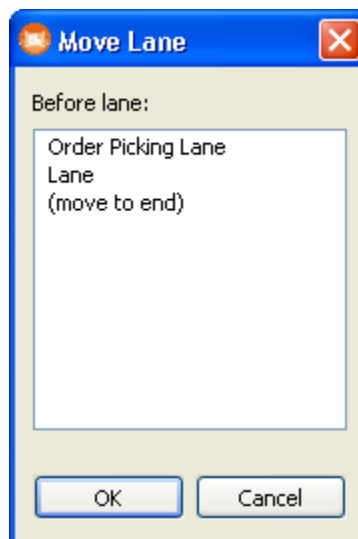

3. From the list of lanes, select the lane you want to move the lane before and click OK.

## Deleting lanes from pools

You can delete lanes from pools in either the [Model View tree](#) or the [diagram](#). This command deletes the lane, and all elements in the lane, from the Model View tree and the diagram. The deleted lane and elements are eliminated from the metamodel and are not available on the clipboard.

**NOTE:** There must always be at least one lane in the pool. You cannot delete all of the lanes or the last lane in a pool.

### Deleting a lane from a pool in the Model view

1. Right-click the lane node you want to delete in the Model View tree and select Delete.

OR

Select Edit > Delete from the main menu.

OR

Press the Delete key. The Delete Elements dialog opens.

**NOTE:** You can also delete multiple lanes. Select a lane node and while holding down the CTRL key, select the other lanes you want to delete.

2. Click Yes to delete the lane from the pool.

**NOTE:** You can delete a lane or multiple lanes from the Model View tree when the diagram is closed.

### Deleting a lane from a pool in a diagram

1. Select the lane you want to delete
2. Right-click in the lane and select Edit > Delete.

OR

Select Edit > Delete from the main menu. OR

Press the Delete key.

**NOTE:** You can also delete multiple lanes. Select a lane and while holding down the CTRL key, select the other lanes you want to delete.

3. From the Delete Elements dialog, click Delete and the selected lane is deleted from the pool.

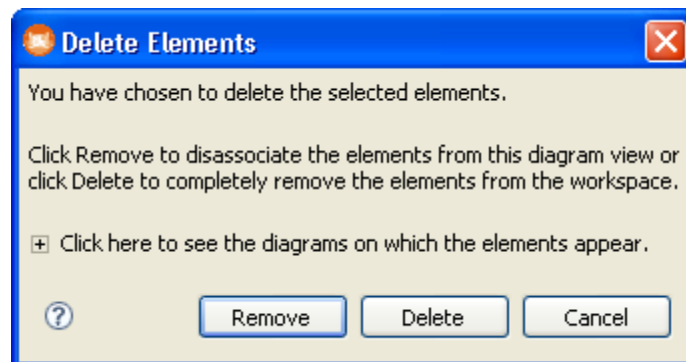

### Removing lanes from pools

You can remove all lanes from a pool or remove just one or more lanes.

#### Removing all lanes from a pool

You can remove (hide) lanes from a pool in the diagram including the last lane. If the last lane is removed, the pool is then a “Black Box” pool.

1. Select the pool you want to remove the lanes from.
2. Right-click in the pool and select Remove All Lanes (Black Box).
 

**NOTE:** When a pool becomes a black box pool, the relationships between items inside the pool and other entities are hidden.
3. To show all lanes right-click in the pool and select Show All Lanes.
 

**NOTE:** If you have the [Validation](#) option set to On, when there is only one lane, then that lane shares the name of the Pool and only the Pool name is displayed.

#### Removing one more lane from a pool in the diagram:

1. Select the lane(s) you want to remove.
2. Right-click in the lane and select Edit > Delete.
 

OR

Select Edit > Delete from the main menu.

OR

Press the Delete key.
3. From the [Deleting Elements](#) dialog, click Remove and the selected lane is removed from the pool on the diagram.

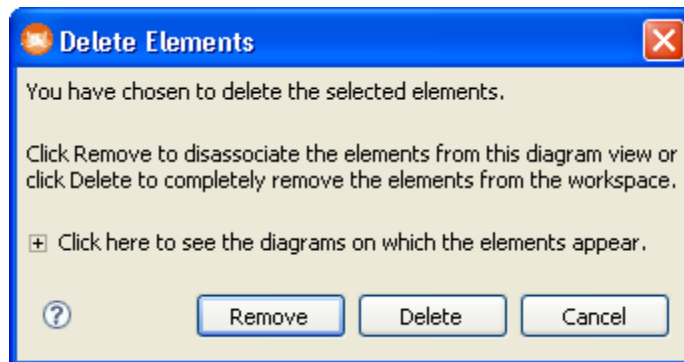





4. To show the removed lane(s) right-click the pool and select Show All Lanes.

## Artifacts

Artifacts provide additional information about the business process. Using artifacts allows you to add non-standard elements to satisfy a specific need. Since you do not want to alter the basic look-and-feel of a diagram, you can use artifacts to link to the existing events and activities through Associations. Artifacts do not affect the basic Sequence Flow or Message Flow, nor do they affect mapping to execution languages.

**NOTE:** If you are entering text in an annotation element, the [autotype](#) text box is closed by pressing Enter.

The current set of artifacts includes: data objects, groups, and annotations. The table below describes the artifacts available from the Business Process Objects Palette:

Artifacts	Palette Icon	Description
Data Object		Data objects provide information about how documents, data, and other objects are used and updated in a Process. They represent data so are defined by a combination of entities or classes. Data Objects are Artifacts because they do not directly affect a Sequence or Message Flow. They provide information on what activities are required or what they produce.
Group		Use the Group symbol to visually organize activities. A Group is represented by a rounded corner rectangle drawn with a dashed border. The grouping can be used for documentation or analysis purposes, but does not affect the Sequence Flow.
Annotation		Textual annotation allows you to provide additional facts and details about an element. Text Annotations are used to provide additional information for the elements of a diagram.
<a href="#">Off-Page Connector</a>		If a process model extends beyond the length of one printed page you can use an Off-Page Connector to show how Sequence Flow connections extend across the page breaks.



# Using conceptual modeling notations

Conceptual modeling is used by enterprise architects, business users, and data architects to model high-level business concepts and subject areas. A common usage of a Conceptual Model is to relate this model to a Logical Data Model. However, it could include other elements like data flow, process, or information assets in addition to more abstract interactions between business 'things', for example, areas of a business and their associations.

The example below shows a basic, high-level conceptual diagram. The main subject area is "US Consumer Banking" and is made up of three other subject areas: "Lending", "Online Banking", and "Securities".

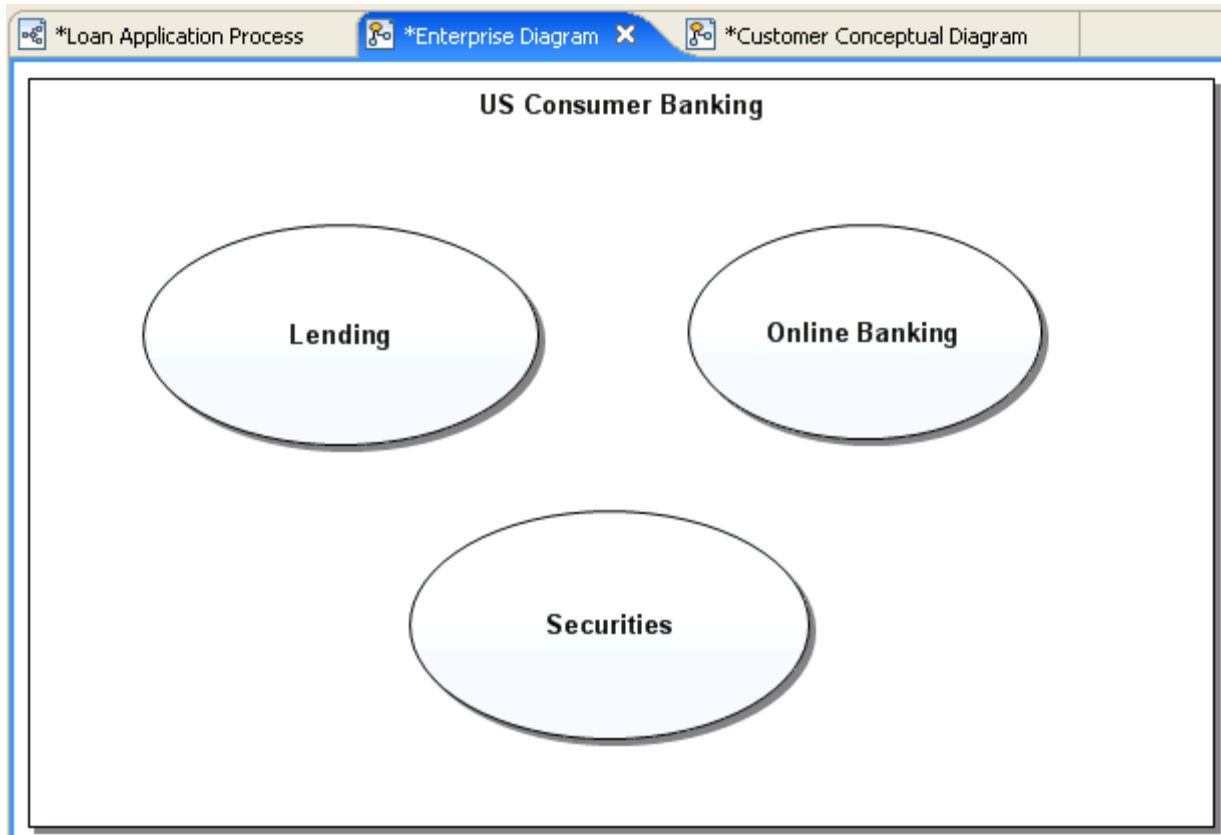

You can add additional information for each subject area for this high-level diagram. For example, you could expand the "Lending" subject area to view the Business Entities and their attributes.

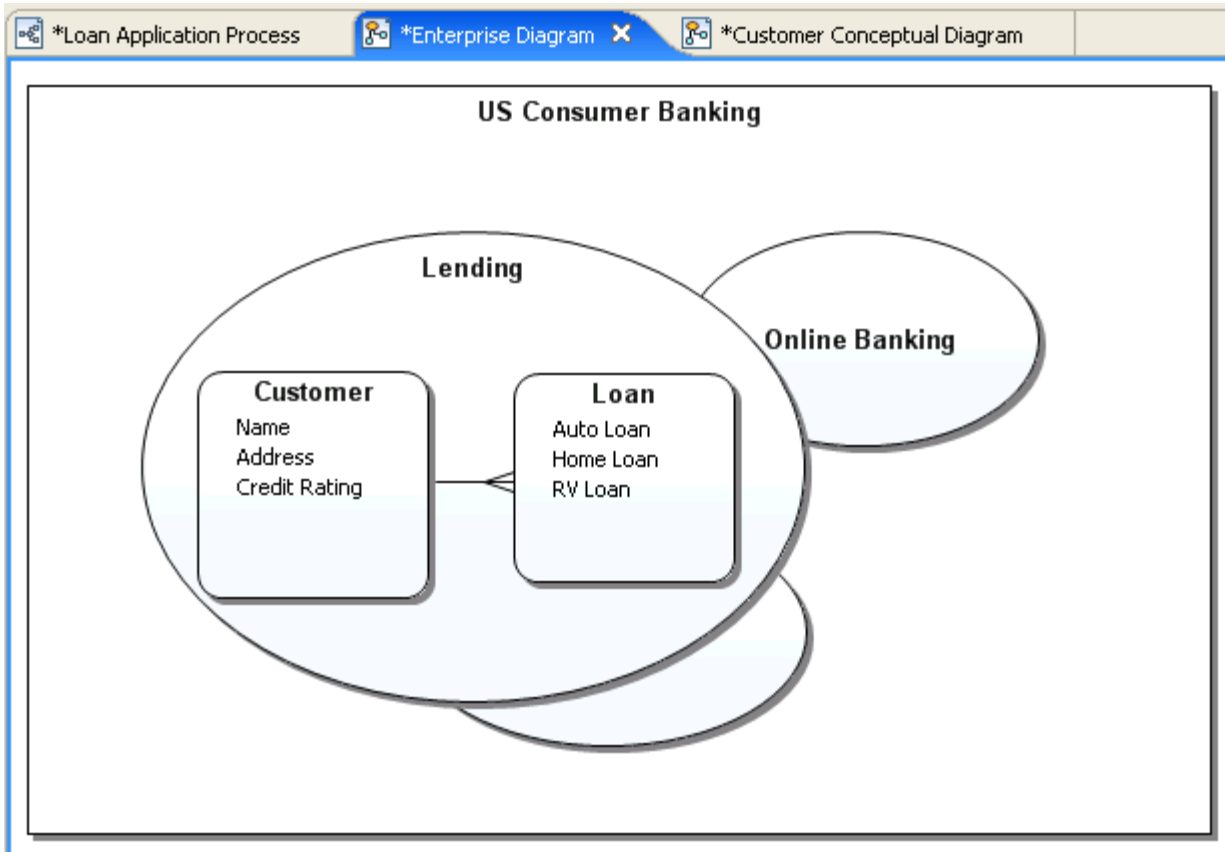



## Conceptual model elements

The table below lists the objects used in creating conceptual models.

Artifact	Palette Icon	Description
<a href="#">Subject Area</a>		A Subject Area is an abstraction of a particular functional area identified in some manner by the business, for example a Sales Organization or Customer. It can also be a functional application area (CRM system, etc.). It can be visualized as a model object and/or used as a grouping mechanism containing other business entities.
<a href="#">Business Entities</a>		Represents a core "object" of the business. Similar in concept to a logical entity in Logical Data Modeling, but at a higher level of abstraction. The audience is often the business user, not a technical data architect. Business Entities are used by data modelers and business users to get basic requirements and descriptions from the business.
<a href="#">Business Attributes</a>		The properties of a business entity, for example, an employee identification number.
<a href="#">Interaction</a>		Interactions represent an action, process, or transaction between two objects. For example, "Customer" -> "Reviews Status of" -> "Orders". They are often expressed as action verb phrases.







Artifact	Palette Icon	Description
<a href="#">Relationship</a>		A relationship between two things representing a loose coupling or association. This is only supported between like object types, for example a Business Entity to a Business Entity. There are four different types of relationships available: Generic, Many-to-Many, Many-to-One, and One-to-Many. You will get an error message if you attempt to create a relationship between a subject area and a business entity.
Group		Use the Group symbol to visually organize elements.

## Subject area

Conceptual Modeling allows Business Users to create high-level designs of the core “concepts” and subject areas that drive the business, which can be passed onto data and process modelers to drive more detailed logical and physical design. A Subject Area can reference a collection of entities. You can embed the entities in the Subject Area, or you can have the Subject Area reference a diagram with multiple entities.

- A Subject Area can be [Create Mapping/Edit Mapping](#) to other Conceptual Model diagrams.
- The Subject Area presentation element in the Diagram View can be shown as an oval or a rectangle. You can set this as a global [preference](#). You can also set the shape for each individual [Subject Area](#) in its Property View. Double-click on a Subject Area, select the Appearance tab in the Property View and then make your selection under the Shape option.
- Subject Areas can be expanded or collapsed. You can then view or hide Business Entities or other Subject Areas within the parent Subject Area. Right-click in a Subject Area in the Diagram View and select *Show as Expanded*. This is a toggle command.
- You can also elect to hide or show the expansion control in the Subject Area in the Diagram View. Right-click the Subject Area and select Show Expansion Control. Depending on the state of the element (expanded or contracted), a plus or minus symbol is placed in the bottom center of the Subject Area. This is a toggle command. You can also choose to show or hide the expansion control as a global [preference](#).
- When a Subject Area is placed in the Diagram View, the label appears vertically centered. Once you add a child element the label is then relocated to the top center of the Subject Area.
- Once other Subject Areas have been placed within a Subject Area, these child items appear on the [Impact Analysis](#) tab under the “Heritage” (  ) heading. You can view this Impact Analysis Report in the Property View for the Subject Area.

**NOTE:** When a Business Entity is placed within a Subject Area, this is a mapping action and appears under the Mappings (  ) heading in the Impact Analysis Report.

- The following example shows a simple, expanded Subject Area with three Business Entities. [Business Entities](#) contain [Business Attributes](#) which are properties of that entity.

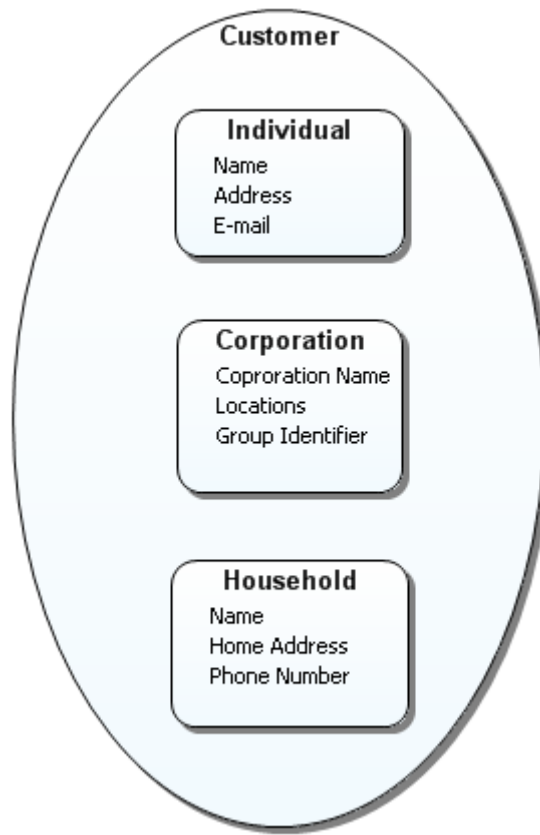

**NOTE:** To select multiple elements in the Subject Area, hold down the ALT key to invoke the [marquee](#) cursor.

### Create mapping

You can create mappings for [Subject Areas](#) to conceptual models, diagrams, and business entities. You can also map to business process model diagrams. A Subject Area can reference a collection of entities in a diagram, or specific individual entities. When a Conceptual model is exported to ER/Studio DA, the Subject Area will be an ER submodel, and all the referenced entities will appear under that submodel.

**NOTE:** All individual entities in a submodel are mapped, not just the model diagrams.

Also, you can create an [Interaction](#) mapping to a Business Process diagram. An interaction represents an action, process, or transaction between two objects. Mapping an interaction to a Business Process diagram provides a quick and easy way to [view](#) the mapped diagram.

Once you have created a mapping you can [view](#), [edit](#), or [delete](#) it.

## Creating subject area mappings

To create references from a Subject Area, use the Mapping functionality. There are three ways to map:

Right-click the Subject Area node that you want to map in either in the Model View tree or in the Diagram View and select Create Mapping.

OR

In the Subject Area Property View, select the Mappings tab and click , and the Create Mapping dialog opens.

**NOTE:** Only the first level business entity is selectable. All nested business entities (i.e., business entity within a business entity) are grayed out and cannot be selected. When you select a top level business entity all child business entities are selected as well. You cannot map only to a nested (or child) entity. Once you have mapped a business entity, you cannot delete only the nested entity. You must delete the first level business entity which includes the nested entity.

OR

Drag and drop Business Entities into a Subject Area. When you drag a Business Entity on a diagram into a Subject Area on a diagram, all contained entities are automatically mapped.

## Creating interaction mappings

To create references from an Interaction to a Business Process diagram, use the Mapping functionality. There are two different ways to map.

- 1 Right-click the Interaction node that you want to map in either in the Model View tree or in the Diagram View and select Create Mapping.

OR

In the Interaction Property View, select the Mappings tab and click , and the Create Mapping dialog opens.

- 2 In this dialog, select the business process diagram from the tree and click OK.

## Viewing the mapping

You can view the results of your mapping three ways depending on what you mapped: (1) in the Property View of the mapped object; (2) via the shortcut menu in the Model View tree; or (3) on the Impact Analysis tab in the Property View.

- Open the Property View either by double-clicking the Subject Area or Interaction in the Diagram View or selecting Properties from the shortcut menu in the Model View tree. Then click the Mappings tab.

**NOTE:** When you double-click the mapped diagram in the Mappings tab of the Property View, the diagram opens in the Diagram View.

- For a Subject Area, if you mapped to a diagram, right-click the Subject Area node in the Model View tree or diagram and select Diagram Mapping. The pull-right displays all diagrams that are mapped.
- To view an Entity's mapping, click the Impact Analysis tab in the Entity's Property View to see what Subject Areas map to it.

### Editing a mapping

Once you have created a mapping, you can then create more mappings or delete existing mappings.

- 1 Right-click the Subject Area either in the Model View tree or in a diagram, select Edit Mapping, and the Edit Mapping dialog opens. For a Subject Area, this dialog lists the workspace, model, diagram(s), and all conceptual model elements for the selected subject area. The elements mapped to the selected subject area are checked.

**NOTE:** When a business entity is grayed out, it cannot be cleared because it is graphically contained by the subject area on one or more diagrams.

For an Interaction, right-click in the Model View tree or in a diagram and select Edit Mappings. The Edit Mappings dialog lists the Business Process diagrams selected.

- 2 Deselect a checked element to delete the mapping. You can also [delete](#) a mapping using the Property View.
- 3 Select an unchecked element and when you click OK, a mapping is created between the selected subject area and the checked element.

### Deleting a Mapping

- 1 Open the Property View for the Subject Area or Interaction containing the created mappings.
- 2 Select the Mappings tab to view the diagrams and/or entities that have been mapped.
- 3 Select the diagram and/or entity you want to remove from the mapping and click .
  - If you have nested entities, you cannot delete only the nested entity. You must delete the parent-level business entity which includes the nested entity. If you select the nested entity to delete, you will get a warning in the Property View.
  - If you have an entity contained in a subject area on a diagram, you cannot delete the mapping. You must remove the mapping by dragging the element out of the Subject Area.

### Business entities

A Business Entity is a high-level "container" for businesses/organizations. They can stand alone or can be containers for other Business Entities or Business Attributes.

- Business Entities can be expanded or collapsed. You can then view or hide other Business Entities and Business Attributes within the parent element. Right-click in a Business Entity in the Diagram View and select Show as Expanded. This is a toggle command.

- You can also elect to hide or show the expansion control in the Business Entity in the Diagram View. Right-click the Business Entity and select Show Expansion Control. Depending on the state of the element (expanded or contracted), a plus or minus symbol is placed in the bottom right-hand corner of the element. This is a toggle command. You can also choose to show or hide the expansion control as a global [preference](#).
- When a Business Entity is placed in the Diagram View, the label appears vertically centered. Once you add a child element the label is then relocated to the top center of the Business Entity.
- Once other Business Entities have been placed within a Business Entity these child items appear on the [Impact Analysis](#) Tab under the "Heritage" (👤) heading. You can view this Impact Analysis Report in the Property View for the Business Entity.
- Business Entities contained in a Subject Area in a diagram are owned by the model, not the subject area.

**NOTE:** When a Business Entity is placed within a Subject Area, the Subject Area is automatically mapped to the entity and appears under the Mappings (🔗) heading in the Impact Analysis Report.

The following example shows two Business Entities containing their related Business Attributes for a shipping company. The two entities are connected with an Interaction showing a many-to-many relationship.

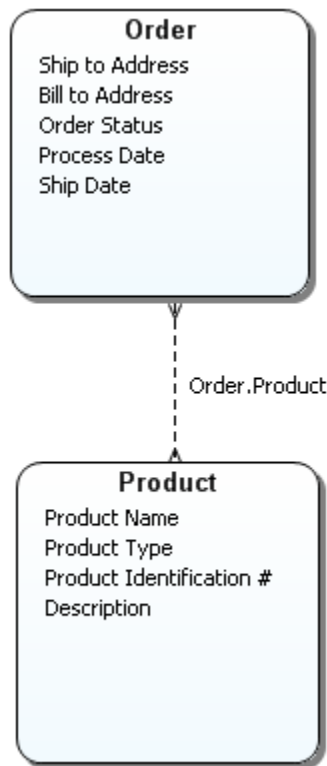

**NOTE:** To select multiple elements in the Business Entity, hold down the ALT key to invoke the [marquee](#) cursor.

## Business attributes

Business Attributes are the low-level details (i.e., properties), of a Business Entity. You can quickly add Business Attributes to a Business Entity by pressing the Insert key while the Business Entity is selected. A new business attribute will be added at the bottom of the list or below a selected Business Attribute. The following example shows the Business Entity “WEB CUSTOMER” with seven Business Attributes for that customer. In this example the Expansion Control is displayed in the lower right-hand corner of the entity.





When working the Business Attributes you can:

- Set [Unique Identifiers](#), which map to Keys in the ER logical model can be set.
- Set the data type for the [Business Attribute](#) in the Property View and. The Data Types available are high level: binary, BLOB/Image, boolean, char, CLOB/Large Text, Decimal, Date, Integer, Time Stamp, Varchar, and XML.
- Set the Optionality for an attribute. If you select Mandatory it becomes a “required” property and a plus sign (+) appears to the left of the attribute. If it is optional, a minus sign (-) appears to the left of the attribute. You can set a [export and/or print](#) under the Display Options for Business Entities to always show the optionality indicator for Business Attributes.
- Bind Business Attributes to [Business Element](#) or [Domains](#) in the Reference Objects node.
- Scroll through the list of attributes in a Business Entity using the up and down arrows.
- [Reorder](#) the Business Attributes within a Business Entity.

### Reordering business attributes

You can reorder business attributes in a Business Entity.

- 1 Double-click the Business Entity that contains the Business Attributes you want to reorder. This opens the Property View.
- 2 Click the Business Attributes tab of Business Entity property view.
- 3 Select the attribute you want to move and click either the up arrow (  ) or the down arrow (  ) to change the order of the attributes.

The change in order is reflected in both the Model View tree and in the element on the Diagram.

## Setting unique identifiers

You can set a unique identifier for a Business Attributes in the Conceptual model making the entity unique. When exporting to ER/Studio DA, Business Attributes designated as unique identifiers are created as entity attributes with the primary key set to True.

The CASE Method (Barker) notations are used as follows:

- Business Attributes, which are parts of the definition of a unique identifier, are shown preceded by hash marks (#). You can show or hide this indicator, if desired.
- [Relationships](#), which are part of the definition of a unique identifier, are marked by a short line across the relationship near the entity being identified.

In the following example, the unique identifier of Line Item is a combination of the attribute "Line No." and the relationship "part of one and only one Purchase Order." Since the marked relationship represents the fact that each line item is partly identified by a particular purchase order, it implies that the Purchase Order's unique identifier "PO Number" participates in identification of the Line Item as well. When implemented, a column derived from "PO Number" is generated in the table derived from Line Item. It serves as a foreign key to the table derived from Purchase Order, and is part of the primary key of the table that is derived from Line Item.

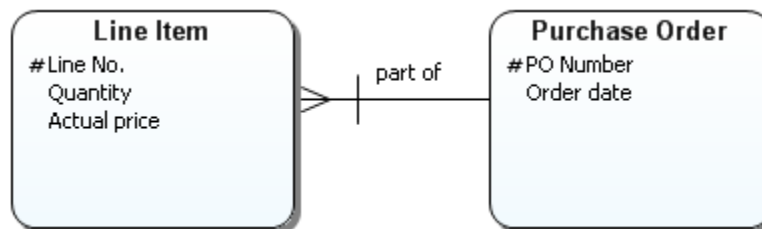

## Relationships

When you set a Unique Identifier for a Business Attribute, all relationships having the Business Entity containing that Business Attribute as the source gets a new indicator. You can show or hide this indicator, if desired.

**NOTE:** If another Business Attribute is set as a Unique Identifier, additional decorators are not added.

## Binding business attributes to business elements

In Conceptual Modeling, a Business Attribute can be "bound" to a [Business Element](#) to seed a conceptual model. You can [export and/or print](#) a binding report. There are several different ways of binding Business Elements to Business Attributes:

- [Binding via Drag and Drop](#)
- [Binding from a Business Attribute](#)
- [Binding from a Business Attribute](#)



The binding characteristics/limitations follow:

- A Business Element can be bound to a Business Attribute.
- You cannot bind both a Domain and a Business Element to the same attribute. You will get a Bound Domain Warning dialog giving you the option to resolve the conflict.
- You can bind multiple Business Attributes to a Business Element in the same Business Entity.
- Once a Business Attribute is bound to a Business Element, changes to the properties (i.e., Name, Description, Notes, and Domain/data type) of the Business Element cascade to the attribute. However, you can use the [Override](#) option if you want to change the enforcement of those properties.

Binding via drag and drop

You can drag a Business Element from the Model View tree onto a Business Entity in the Diagram View.

- 1 Select the Business Element you want to bind with a Business Entity.
- 2 Drag the Business Element from the Model View onto the Business Entity in the Diagram View.
- 3 If the entity already contains a bound Business Attribute with the same name, the Duplicate Attribute Exists dialog opens.

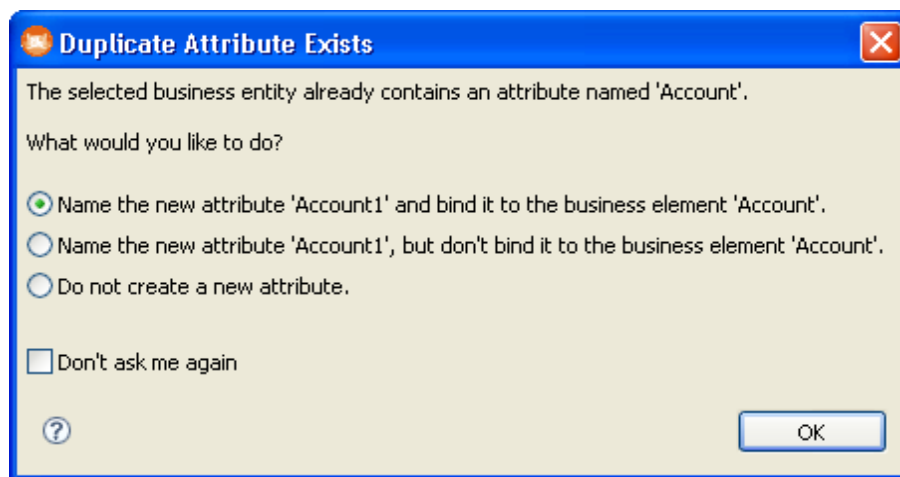

- Select the first option if you want to bind the element to a new business attribute. This action creates a new attribute with a unique name. For example, if your existing attribute was "Element", the new attribute would be "Element1".
- The second option creates a new attribute with a new name but does not bind it to the Business Element.
- Select the last option if you do not want to create a new attribute. This selection cancels your drag and drop action.

Binding from a business attribute

To bind a Business Attribute to a Business Element:

- 1 Double-click a Business Attribute either in the Model View tree or in the Diagram View to open the Property View.
- 2 On the General tab, in the Business Element Binding options box, click the drop-down arrow in the Bound Business Element list box. All available Business Elements are listed.
- 3 Select the Business Element you want to bind the Business Attribute to.

**NOTE:** If a naming conflict exists, (i.e. duplicate names) the Duplicate Attribute Exists dialog opens allowing you to resolve the conflict.

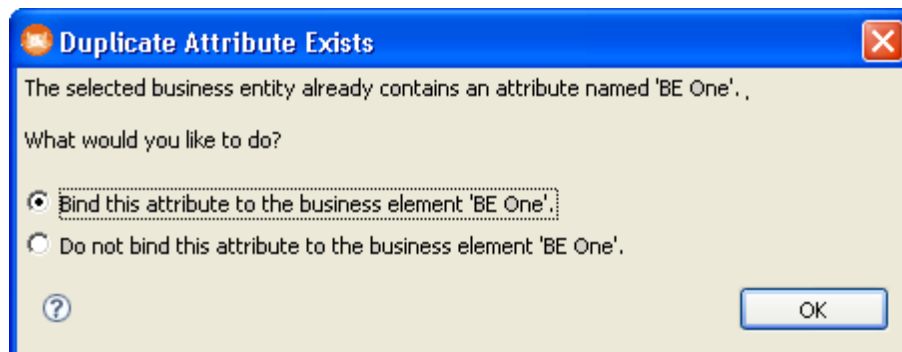

- 4 You can choose to override the properties of a bound Business Attribute (Name, Description, Notes, and Domain/data type) with the changes you make in the Business Element. For example, you can change the Data type setting of "Account" as shown in the following screen shot. Because the Domain/datatype enforcement option is selected in the Enforcement options box, that value is propagated to the bound Business Attribute.

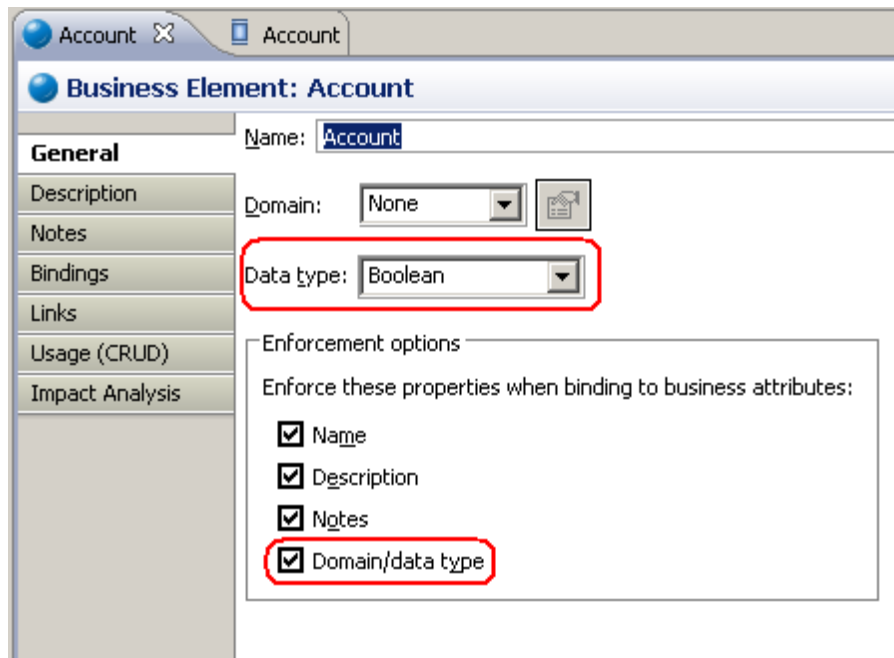

When you open the Property View for the bound Business Attribute, notice that the Data type setting is now the same as the "Account" Data type setting.



- 5 If you change any of the properties in the bound Business Attribute a violation occurs telling you that one or more properties of the Business Element and the Business Attribute no longer match. For example if you changed the Data Type to "Decimal" in the Business Attribute, a violation notice appears in the Bindings hierarchy. Click Bindings and notice that a "Data Type Violation: Decimal" warning appears in the hierarchy.

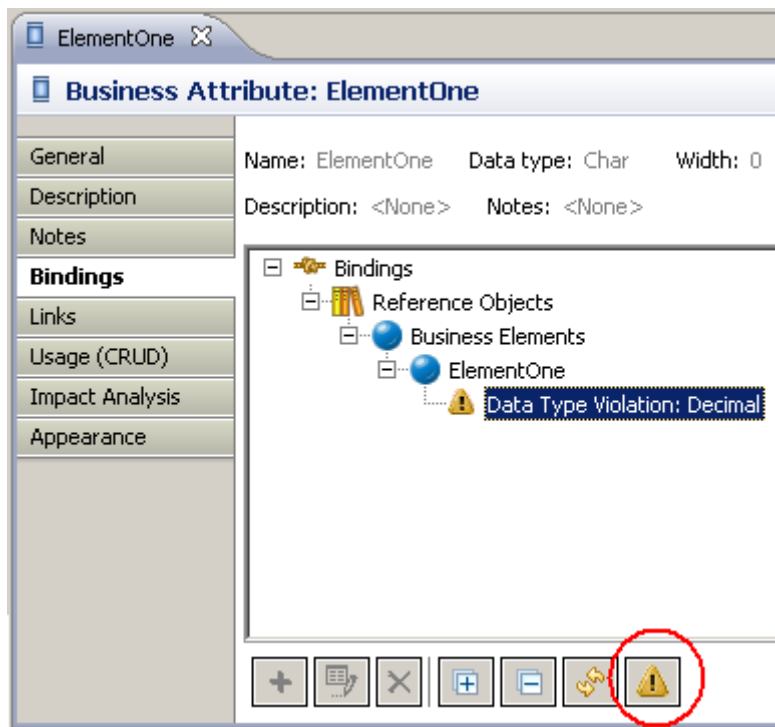

- 6 You can choose to resolve the violations by clicking . Violations do not have to be resolved and are left in the Bindings hierarchy as a reminder of the changes you made.

### Viewing the binding

There is no visual indicator on the diagram showing that a Business Element has been bound to the Business Attribute. However, you can view the binding either from the Business Attribute or from the Business Element via their Property Views:

- When you double-click the bound Business Attribute, the Property View for the attribute opens. Click Bindings and the bindings hierarchy is shown under the Bindings heading (). This hierarchy shows the Business Elements the Business Attribute is bound to.

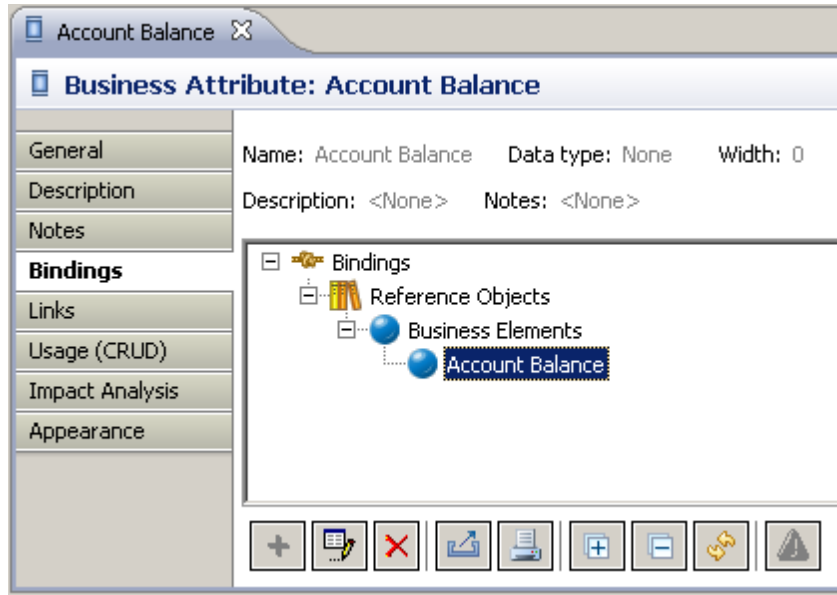

- When you double-click on a Business Element, the Property View for that element opens. Click Bindings to view the attributes bound to an element.

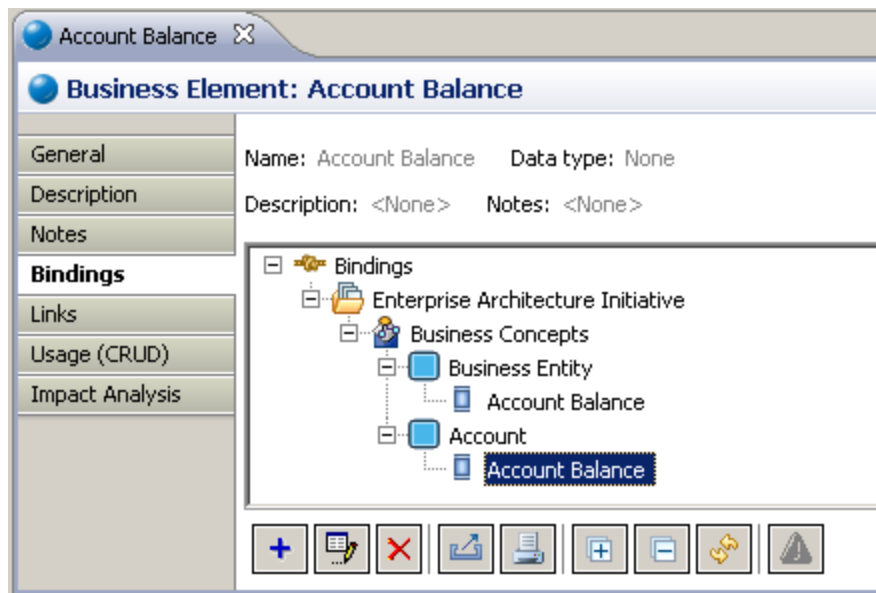

Binding from a business element

To bind a Business Attribute from a Business Element:

- 1 Double-click a Business Element either in the Model View tree or in the Diagram View to open the Property View.
- 2 Click the Bindings tab to open the Bindings hierarchy page.

- 3 Click  and the Creating Binding with Targets... dialog opens. All Business Entities and their associated unbound Business Attributes are listed.

**NOTE:** If a binding has already been created, the Add Target to Binding... dialog opens.

- 4 Select the target (i.e. attribute) you want to bind with the Business Element and click OK.

**NOTE:** If you attempt to bind an attribute that is already bound to a Domain, you will get a Bound Domain Warning Dialog.

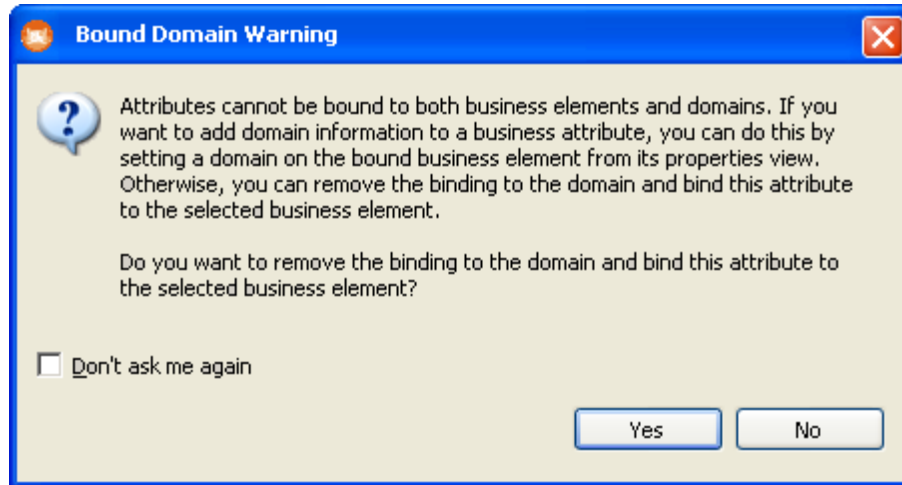

- 5 In the Property View for the Business Element, click Bindings to view the Bindings hierarchy.

#### Using the Override option

When binding Business Attributes to Business Elements you can choose to enforce some or all of the properties of the Business Element to the Business Attribute.

- 1 Create a Business Element and select the properties you want enforced when binding to Business Attributes. In the following example, when you bind a Business Attribute to ElementOne, the Name and Domain/data type properties will be enforced on the Business Attribute. The Description and Notes properties of the Business Elements will not be enforced.

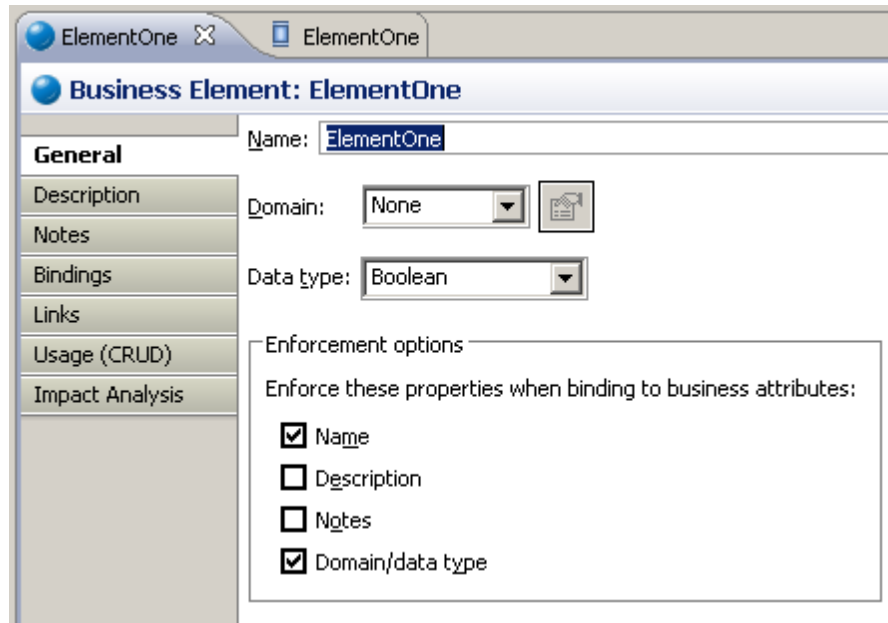

- 2 However, when you bind the Business Attribute to the Business Element, you have the option to override the enforced properties. In the following example notice that in the Business Attribute Property View, the Description and Notes options are greyed out. Also notice that the Name and Data type list boxes are not available.

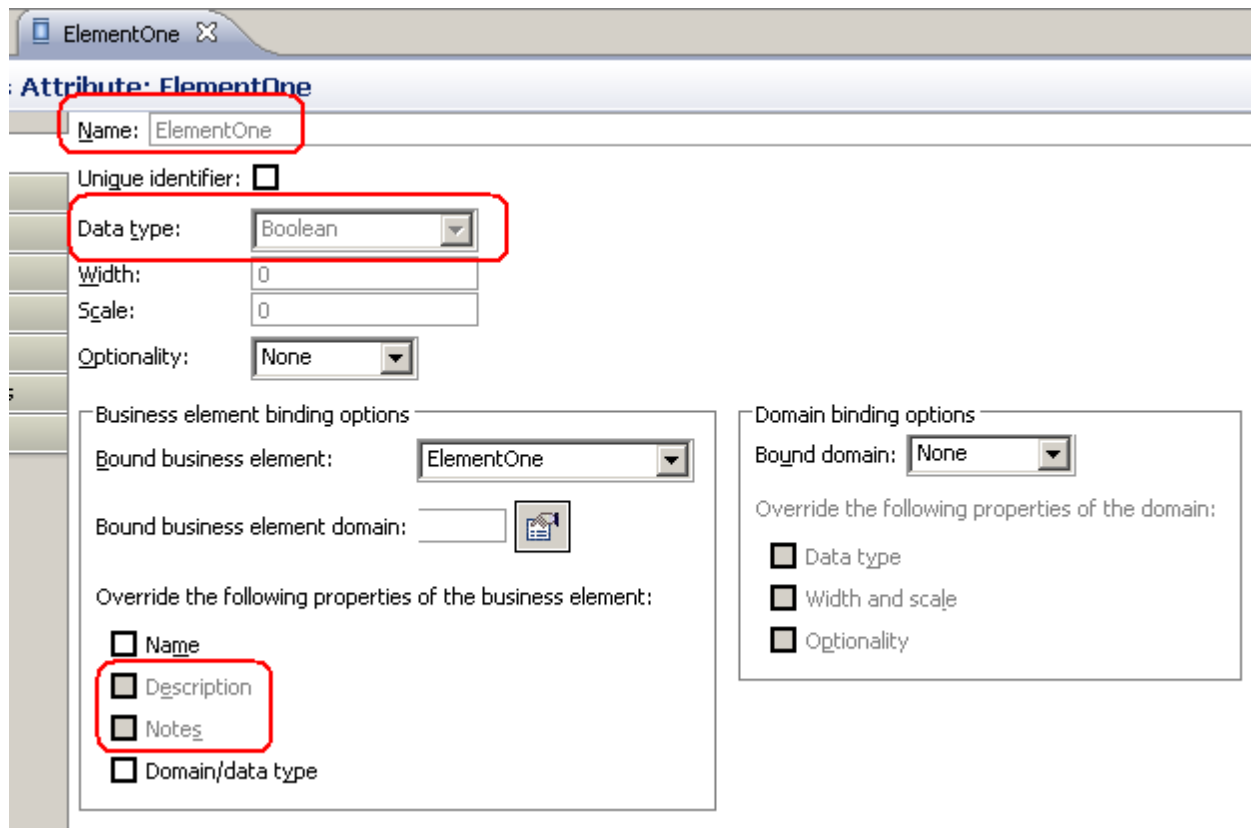

- 3 If you want to override any of the available properties, select that option in the Business Element binding options. For example, if you selected the Domain/data type option, the Data Type list box becomes available and you can change the setting.

- Once you override a property and click on the Bindings tab, a violation notation appears in the hierarchy telling you that the properties of the Business Attribute and the Business Element no longer match and what that mismatch is.

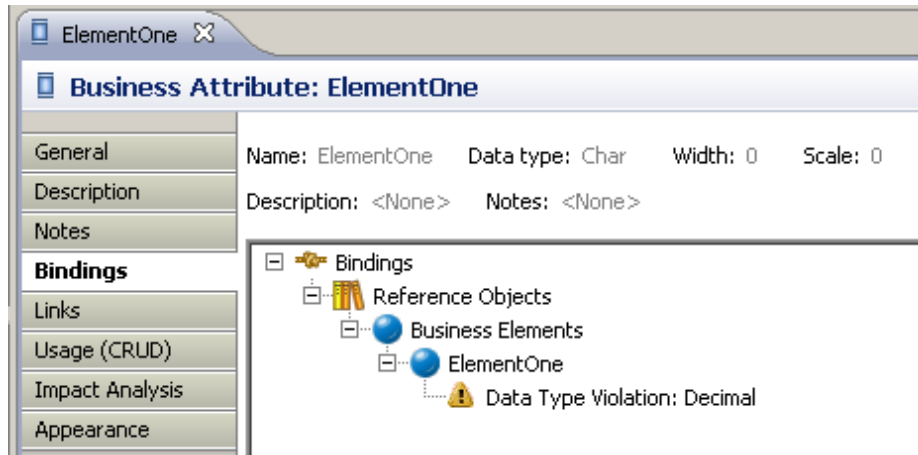

## Binding business attributes to domains

In Conceptual Modeling, a Business Attribute can be “bound” to a [Domain](#) to seed a conceptual model and enforce data type standards. You can [export and/or print](#) a binding report. There are several different ways of binding Domains to Business Attributes:

- [Binding via Drag and Drop](#)
- [Binding from a Business Attribute](#)
- [Binding from a Domain](#)

The binding characteristics/limitations follow:

- A Business Attribute can be bound to a Domain.
- You cannot bind both a Domain and a Business Element to the same attribute. You will get a Bound Domain Warning dialog giving you the option to resolve the conflict.

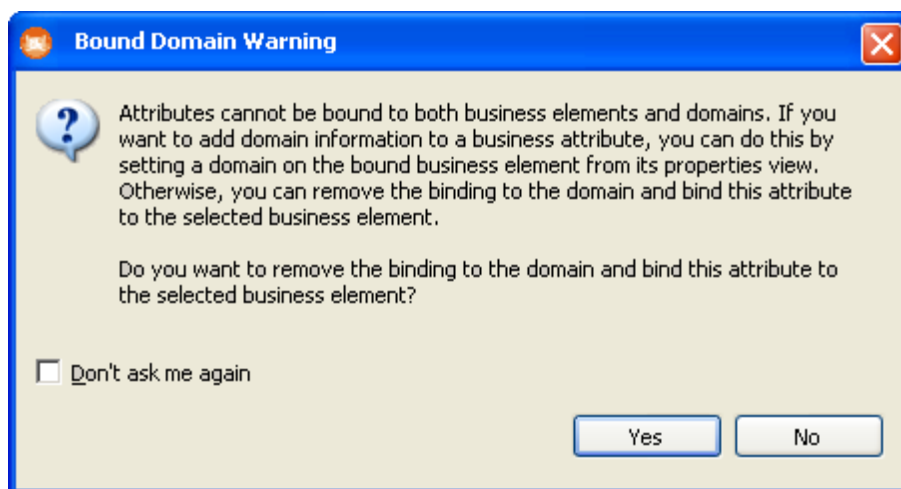

- You can bind multiple Business Attributes to a Domain in the same Business Entity.



- Once a Business Attribute is bound to a Domain, changes to the properties (i.e., data type, width and scale, and optionality) of the Domain cascade to the attribute. However you can use the [Override](#) option if you want to change the enforcement of those properties.

### Binding via drag and drop

You can drag a Domain from the Model View tree onto a Business Entity in the Diagram View.

- 1 Select the Domain you want to bind with a Business Entity.
- 2 Drag the Domain from the Model View onto the Business Entity in the Diagram View.
- 3 If the entity already contains a bound Business Attribute with the same name, a new attribute is created with a unique name. For example, if your existing attribute was "Domain", the new attribute would be "Domain1".

### Binding from a business attribute

To bind a Business Attribute to a Domain:

- 1 Double-click a Business Attribute either in the Model View tree or in the Diagram View to open the Property View.
- 2 On the General tab, in the Domain Binding Options group box, click the drop-down arrow in the Bound Domain list box. All available Domains are listed.
- 3 Select the Domain you want to bind the Business Attribute to.
- 4 You can choose to override the properties of a bound Business Attribute (data type, width and scale, and optionality) with the changes you make in the Domain. For example, you can change the width setting of "DomainOne" as shown in the following screen shot. Because the Width and Scale enforcement option is selected in the Enforcement options box, that value is propagated to the bound Business Attribute.

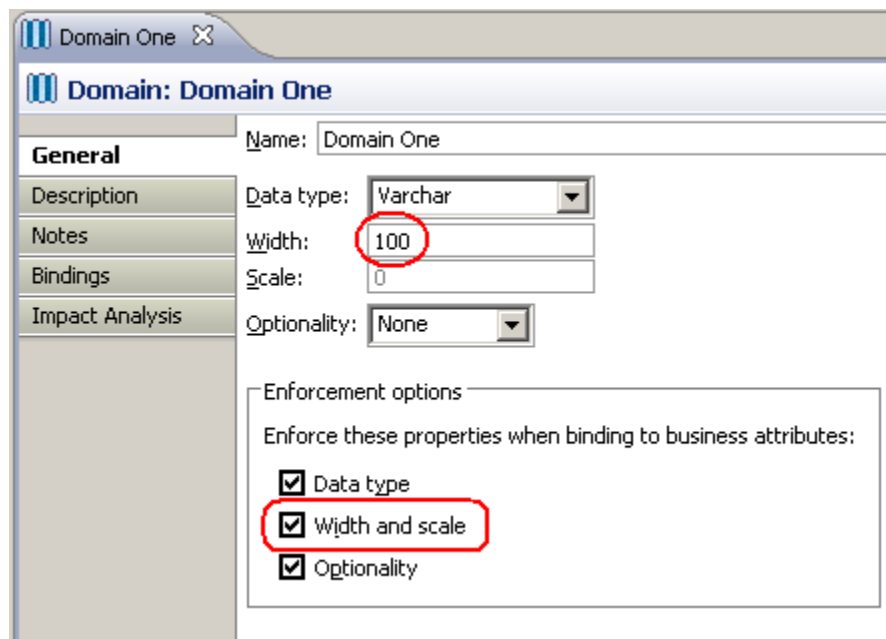

When you open the Property View for the bound Business Attribute, notice that the Width setting is now the same as the *Domain One* width setting.

- If you change any of the properties in the bound Business Attribute a violation occurs telling you that one or more properties of the Domain and the Business Attribute no longer match. For example if you changed the Data Type to "Binary" in the Business Attribute, a violation notice appears in the Bindings hierarchy. Click Bindings and notice that a "Data Type Violation: Varchar" warning appears in the hierarchy.

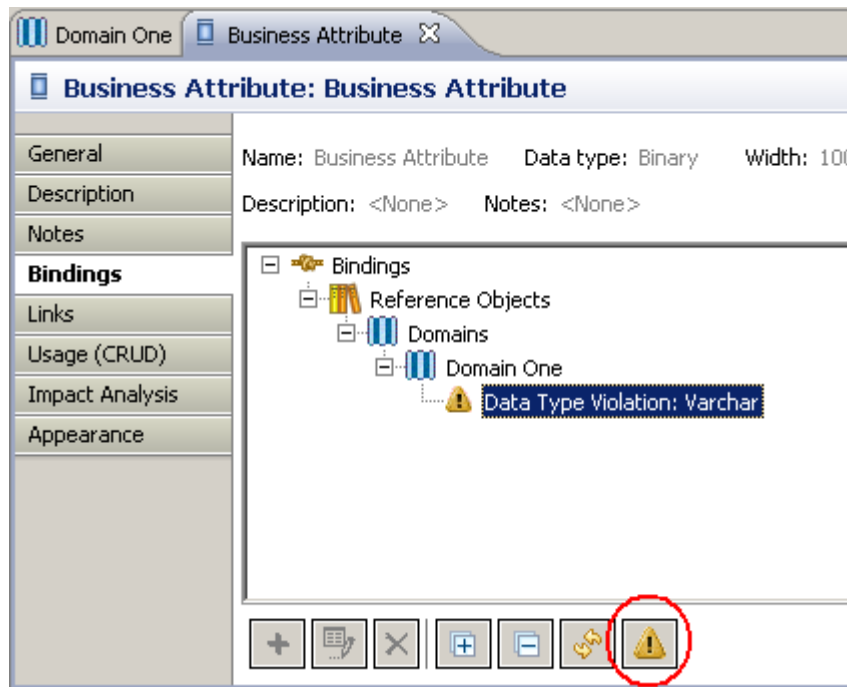

- You can choose to resolve the violations by clicking . However, violations do not have to be resolved and are left in the Bindings hierarchy as a reminder of the changes you made.

### Viewing the binding

There is no visual indicator on the diagram showing that a Business Attribute has been bound to a Domain. However, you can view the binding either from the Business Attribute or from the Domain via their Property Views:

- When you double-click the bound Business Attribute, the Property View for the attribute opens. Click Bindings and the bindings hierarchy is shown under the Bindings heading (  ). This hierarchy shows the Domain(s) the Business Attribute is bound to.

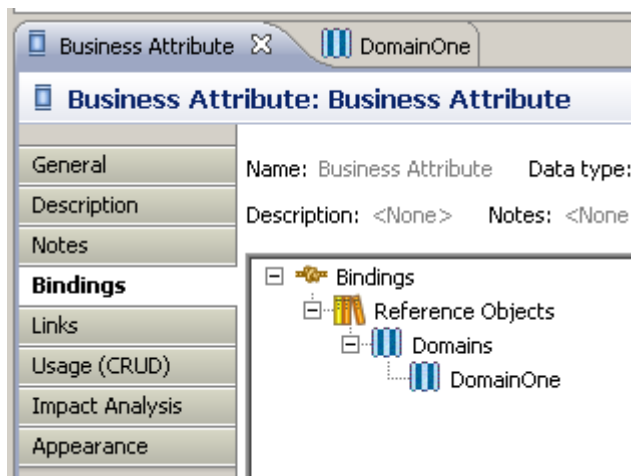

- When you double-click on a Domain, the Property View opens. Click Bindings to view the attributes bound to the Domain.

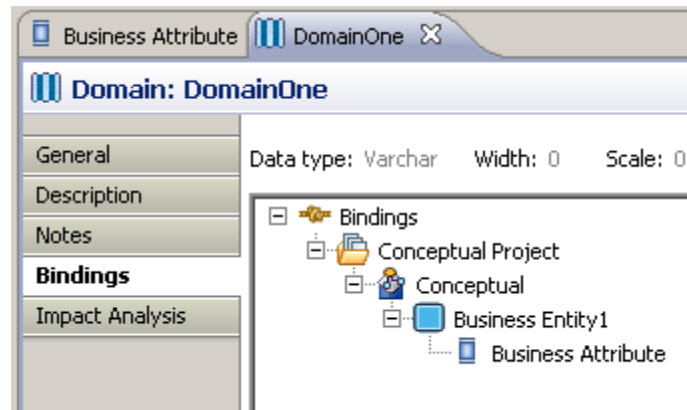

Binding from a domain

To bind a Business Attribute from a Domain:

- 1 Double-click a Domain either in the Model View tree or in the Diagram View to open the Property View.
- 2 Click the Bindings tab to open the Bindings hierarchy page.
- 3 Click  and the Creating Binding with Targets... dialog opens. All Business Entities and their associated Business Attributes and Domains are listed.

**NOTE:** If a binding has already been created, the Add Target to Binding... dialog opens.

- 4 Select the target (i.e. attribute) you want to bind to the Domain and click OK.

**NOTE:** If you attempt to bind an attribute that is already bound to a Business Element, you will get a Bound Domain Warning dialog.

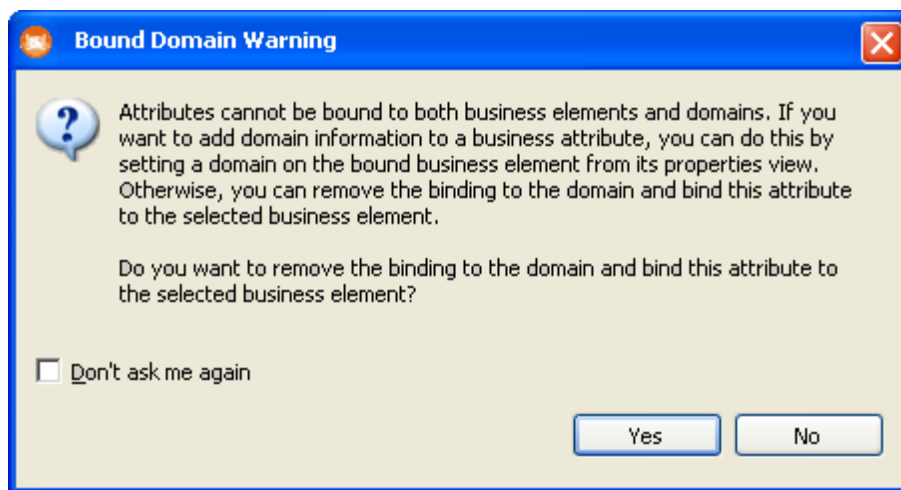

- 5 In the Property View for the Domain, click Bindings to view the Bindings hierarchy.

Using the Override option

When binding Business Attributes to Domains you can choose to enforce some or all of the properties of the Domain to the Business Attribute.

- 1 Create a Domain and select the properties you want enforced when binding to Business Attributes. In the following example, when you bind a Business Attribute to DomainOne, the Data Type and Optionality properties will be enforced on the Business Attribute. The Width and Scale properties of the Domain will not be enforced.

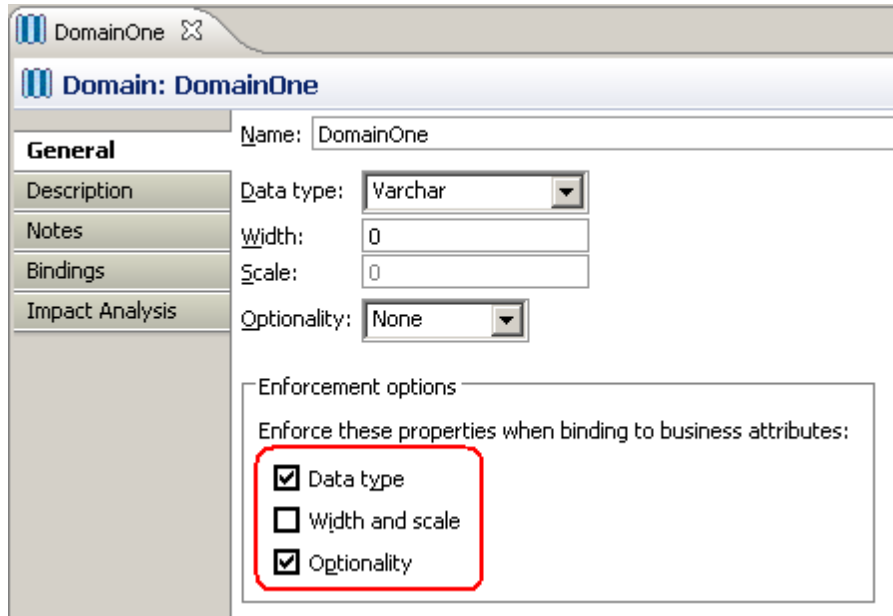

- 2 However, when you bind the Business Attribute to the Domain, you have the option to override the enforced properties. In the following example notice that in the Business Attribute Property View, the Width and Scale option is greyed out. Also notice that the Data type and Optionality list boxes are not available.



Name: Business Attribute

Unique identifier:

Data type: Varchar

Width: 0

Scale: 0

Optionality: None

Business element binding options

Bound business element: None

Bound business element domain:

Override the following properties of the business element:

- Name
- Description
- Notes
- Domain/data type

Domain binding options

Bound domain: DomainOne

Override the following properties of the domain:

- Data type
- Width and scale
- Optionality

- 3 If you want to override any of the available properties, select that option in the Domain binding options. For example, if you selected the Data Type option, the Data Type list box becomes available and you can change the setting.
- 4 Once you override a property and click on the Bindings tab a violation notation appears in the hierarchy telling you that the properties of the Business Attribute and the Domain no longer match and what that mismatch is.

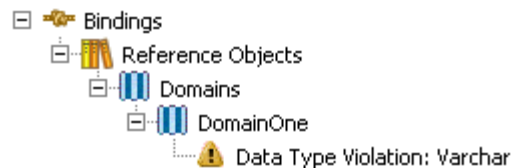

## Printing and exporting bindings

You can print or export binding resolutions as a report. You could have several hundred items that were overridden and want to see that information in another file or printed to paper.

### Export Bindings Report

To export a Bindings Report:

- 1 On the Bindings tab of a business element containing bindings or a bound business attribute, click .
- 2 In the Export dialog, select the workspace where you want the report created.
- 3 The default report name is based on the name of the business attribute. You can edit this name.
- 4 In the Save as Type text box, select the format from the drop-down list. Your options are: html, pdf, and rtf.
- 5 Click Save and the report is generated.
- 6 To view this report, go to the directory where it was saved and double-click on the report name.

### Print Bindings Report

To print a Bindings Report:

- 1 In the Bindings tab of a business element containing bindings or a bound business attribute, click .
- 2 In the Print dialog, select the Printer and click OK.

## Interaction

An interaction represents an action, process, or transaction between two objects. These interactions are often expressed as action verb phrases. The verb and inverse verb phrases can be added using the [Property View](#) and then displayed in the Diagram View. You can also [create a mapping](#) from the Interaction to a business process diagram.

You can set line style, line thickness, end point selection, and begin point selection for the [Interaction](#) in the Property View. You can also set global preferences for all the line display options in the [Preferences](#).

The following diagram shows two interactions between the Business Entities. The “Shop in Store” interaction displays the verb and inverse verb phrases that were added in the Property View for that Interaction.

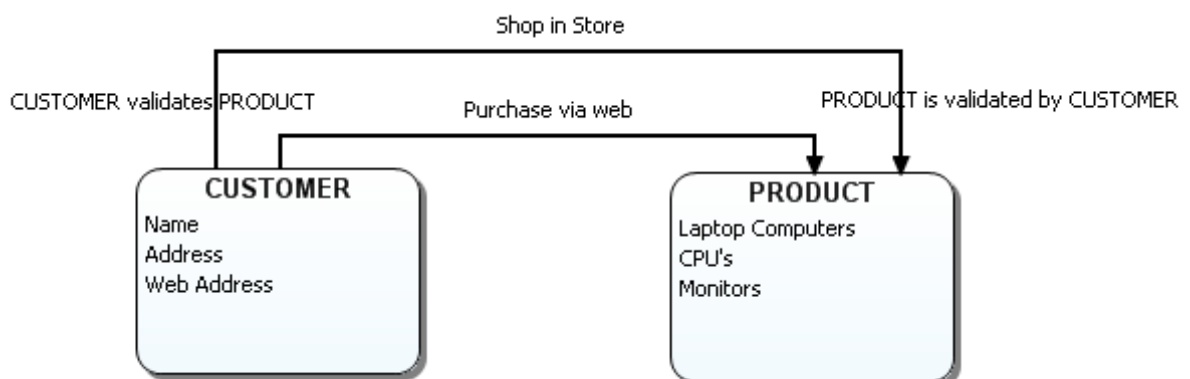

## Relationship

Relationships can only be defined between common object types. For example two business entities can have a relationship, but a business entity and a subject area cannot.

You can set Relationship properties using the Property View. These properties include the following:

- You can add verb and inverse verb phrases which are then displayed in the Diagram View.
- You can set the [optionality](#) of the relationship.
- You can choose one of four different relationship types:
  - Generic (-----). You can customize the end points using the [Line Display Options](#) in the Appearance tab of the Property View.
  - Many-to-Many (⇄)
  - Many-to-One (⇨)
  - One-to-Many (⇩)
- The selection you make is reflected on the beginning and ending indicator on the relationship.
- You can set line style, line width, and source/target decorator size for the Relationship in the Property View under the Appearance tab.
- You can also set global preferences for all the line display options in the [Preferences](#).

The following diagram shows a one-to-many relationship with an optionality setting of Mandatory to Optional between two related Business Entities.

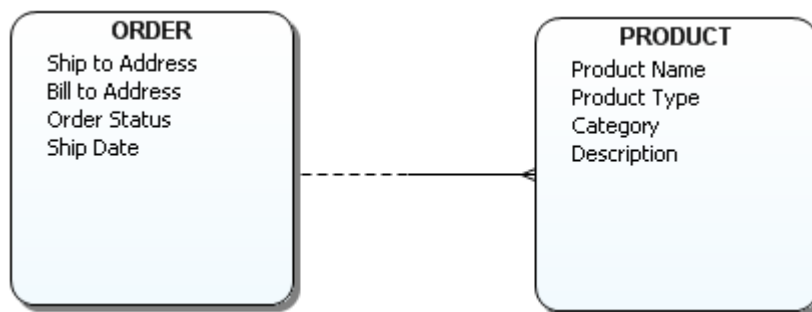



### Setting the optionality of a relationship

Split-line notation appears when you set source/target optionality on a Conceptual Model relationship. The line display depends on the optionality selected for the relationship. The following options are available:

- Optional to Mandatory
- Mandatory to Optional
- Optional
- Mandatory

To set the optionality of a relationship

- 1 In the Diagram View, double-click the Relationship to open the Property View.

OR

In the Model View, double-click either the **Outgoing Relationships** or **Incoming Relationships** icon (.....) located in either the target or source elements to open the Property View.

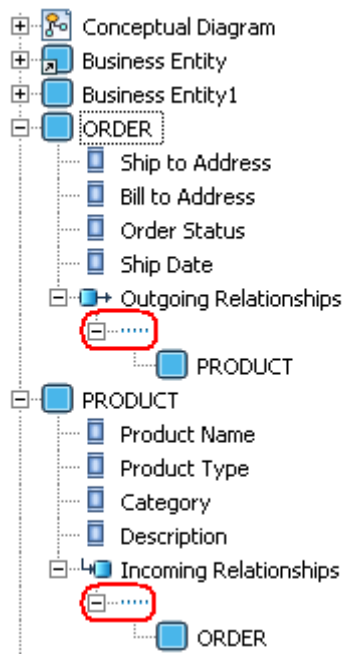

- 2 Select the Relationship Type from the drop down list and the Relationship display in the Diagram View changes to reflect the type chosen.
- 3 Select the Optionality from the drop-down list and the split-line notation displayed reflect the optionality chosen.
- 4 You can customize the end points using the [Line Display Options](#) in the Appearance tab of the Property View.



# ER/Studio Business Architect tools

ER/Studio BA Tools outlines how to use the tools and features. The table below describes the different sections of this chapter:

Topic	Description
<a href="#">Create Diagram from Selected Elements</a>	This function gives you the ability to create diagrams from both Business Process and Conceptual Model elements that exist on the Model View tree or on a diagram.
<a href="#">Find</a>	The Find functions give you the ability to find information in the current diagram.
<a href="#">Search</a>	A Search dialog lets you search for elements, or specific text in descriptions and notes. You can filter the search parameters and view the results in the Search Results view.
<a href="#">Links</a>	There are two wizards that walk you through the creation or editing of a link relationship between elements.
<a href="#">Usages</a>	There are two wizards that walk you through the creation or editing of a usage relationship between elements.
<a href="#">Impact Analysis Diagram</a>	This is a graphical representation of the links or usages you created. You can also update an existing diagram.
<a href="#">Grid Editor</a>	The Grid Editor is a spreadsheet-like display format used as an alternative to the Tree view. This is valuable for displaying large numbers of objects or business-related textual objects, such as business rules. Grid Editors can be printed or exported as a report in csv, html, pdf, and rtf formats.
<a href="#">Reports</a>	<b>Note:</b> There are two main reports in ER/Studio BA: the Impact Analysis Report and the Web Report.
<a href="#">Views</a>	Views support editors and provides alternative presentations as well as ways to navigate the information in ER/Studio BA.

## Create diagram from selected elements

You can create new diagrams from existing model objects for both Business Process and Conceptual diagrams. To do this, you can select model elements in the Model View tree or right-click on elements in an open diagram. You can then [create](#) a diagram from the selected elements. This command is also available on the Tools main menu.

**NOTE:** The newly-created diagram is displayed in the Model View tree with the elements displayed as presentation elements, which is indicated by a special marker on the element icons ()

Specific rules apply to both the [Business Process Model](#) and [Conceptual Model](#) diagrams. The following rules apply in general to the creation process:

- Any combination of Reference Objects or External Data Objects can be selected and added in combination with Business Process or Conceptual Model elements, with the following exceptions: (1) Business Process triggers; (2) External Data Object attributes, columns, and data elements; and (3) Reference Object Domains.
- The Create Diagram from Selected Elements command is disabled when an invalid combination of elements are selected. Those invalid combinations include:
  - Combinations of Business Process or Conceptual Model elements
  - Elements from more than one model (with the exception of Reference and/or External Data Objects).
  - Selections which include items which cannot be displayed on a diagram.
  - Elements which cannot be created on a diagram.
- When creating a diagram from selected elements, relationships are discovered on the new diagram. However, a relationship can only be discovered when both the source and target nodes are selected when creating the diagram.

## Creating business process model diagrams

When creating a diagram from Business Process Model elements, only one diagram can exist in a Business Process model that shows a private (internal) process (i.e., without pool/lanes). A new Business Process diagram can be created using this command when the following conditions are met:

- This command is only available for pools in a Business Process model and only pools in the same model can be selected.
- This command is not available for a combination of elements in different models.
- Elements of the same process are selected, where there is not already an existing diagram representing that abstract process.
- All Reference Objects and External Data Objects can be selected and included when creating a diagram.

## Creating conceptual model diagrams

New diagrams can be created from existing Business Entities, Subject Areas, and Groups, assuming they are all in the same model. All Conceptual Model elements can be selected to create a new diagram, with the following clarifications:

- This command is available for Business Entities, Subject Areas, and Group, but not for Business Attributes or Relationships.
- If only Subject Areas, Business Entities, or Groups are selected, the relationships are discovered and drawn.
- If Interactions and Relationships connecting elements are selected, they are also included on the diagram.
- If a connecting element is selected without a target or source element, the source and target element are discovered and included on the diagram.

## Using the Create diagram from Selected Elements command

- 1 Right-click on a selected element in either the Model View or an open diagram and click Create Diagram from Selected Elements.

**NOTE:** Hold down the CTRL key to select multiple elements, for example a Subject Area and a Business Element.

- 2 In the New Diagram dialog, enter the new diagram's name and description.

**NOTE:** In the New Diagram dialog, the available model(s) depend on what model elements are selected. For example, if only pools are selected, the pool's model is the only model available. If only reference objects are selected, all models are available.

- 3 Click OK, the New Diagram dialog closes and the newly-created diagram opens in the Diagram View area. The diagram also appears in the Model View tree under the model node you specified when you created the diagram.

## Find

The Find function has two different ways to find elements: [Finding in Diagram](#) and [Finding in Model View](#).

### Finding in diagram

This option lets you search for an object name in an active diagram. The found element is then highlighted in the diagram.

- 1 On the Main menu, select Edit > Find in Diagram... or press CTRL+F and the Find dialog displays.
- 2 Enter the name of the element you want to find. This searches for any element in the current diagram
- 3 You can select the options to match whole words only or match case at this point.

**NOTE:** "Match whole word only" looks for a full match. If you want to do a partial match, you would keep this unchecked. Also, the "Match case" option looks at case.

- 4 Select the direction you want to search. In this case direction means up or down, searching an internal list that is created when the Find operation starts.

**NOTE:** If multiple elements are found, the Find Next command selects the next match based on the direction you have indicated.

- 5 Click OK and the found object is centered and highlighted in the Diagram Area.

- If a search item is not found, a Message dialog opens telling you that there are no elements on the diagram that meet the search criteria.
- If you have found all items in that diagram you will get a message that there are no more elements on the active diagram meeting the search criteria

## Finding in Model view

This function lets you quickly locate an element on an active diagram in the Model View tree.





- Right-click an element in the Diagram Area and click Find in Model View or click CTRL+H. The element is highlighted in the Model View tree.

## Search

You can do an advanced search of the workspace using this function. Once a search is complete a Results View appears with all matches listed. On this view, you can find where an element resides in the workspace and on which diagram(s) (opened and closed) they appear.

- 1 Select Edit > Search or press CTRL+E to open the Search dialog.
- 2 The table below describes each field of this dialog:

Field	Description
Find What	Enter the name of the item you want to search for. A drop-down arrow gives you access to the last ten search strings. You can set a <a href="#">preference</a> for the number of entries in this list.
Find	Click Find to start the search. This button is not enabled if the search string is blank.
Match Case	The search matches the exact case of the search string.
Match whole words only	The search matches a whole word, not partial search strings.
Search In...	You can choose what you want included in the search: Entire workspace, or specific projects, models, and data sources.
Look For	Select a type of items you want to look for: Names (of elements), Descriptions, or Notes.

Field	Description
Limit To	<p>You can choose what types of elements should be searched. This filter limits what types should be included in the search. You have the following options in this tree:</p> <p>Expand: Click  to expand all nodes of the tree.</p> <p>Collapse: Click  to collapse all nodes of the tree.</p> <p>Select All: Click  to select all nodes of the tree.</p> <p>Clear All: Click  to clear all selections made in the tree. </p>
Restore Defaults	You can click Restore Defaults to reset all the values back to their original settings.

3 Once you made all your settings in the Search dialog, click Find. A progress dialog may or may not be shown depending on the time it takes to do the search.

4 Once the search is complete, a Search Results view opens.

## Search Results view

This view opens automatically after a search is completed if it isn't already displayed. A Search Result Count header displays the number of found items. The table displays five columns:

Column	Description
Name	Name of the element you searched for.
Type	Element type
Description	Displays the descriptive text for the element.
Notes	Displays the note text for the element.
Parent	The element's owner. This is required if multiple elements appear with the same name.

You can gain access to the commands for the View either through a shortcut menu or the toolbar.

**NOTE:** You can set [preferences](#) for the number of elements to return, as well as what columns you want to be displayed.

## Using the Shortcut menu

- 1 Right-click on a populated row in the Search Results view and the following commands are available to you:

Shortcut Menu Item	Description
Name, Type, Description, Notes	By default, all columns are displayed. These are toggle settings, so you can select or deselect which columns you want displayed.
Open Search Dialog	Opens the Search dialog so you can specify a new search or modify your existing search.
Find In	Opens a pull-right menu with the following commands: <b>Active Diagram:</b> This command finds and highlights the selected search item in the active diagram. This command is not available if the element exists only in the Model View. <b>All Diagrams:</b> This command searches for the selected search item on all diagrams in the model. The Diagram Usage dialog opens displaying all the diagrams where the element appears. Select the diagram you want to open and click OK. <b>Model View:</b> Finds the selected search item in the Model View tree.
Run Previous Search	The pull-right menu displays the previous searches. Up to ten searches are listed. You can also select the Clear History option.
Filter Results	Opens the Search Results Filter dialog. Use this to refine the search. You can select which types of objects you don't want to see in the Results view. You can expand or collapse the tree. You can also select or deselect all the tree node items.
Customize Columns	Opens the Customize Columns dialog where you select the columns you want displayed in the Search Results view.
Properties	Opens the Property View for the selected search item.







- 2 Double-click on a search results row and the associated property view is displayed.

## Using the toolbar

The following commands are available in the Search Results view toolbar:

Command	Icon	Description
Search		Opens the Search dialog so you can specify a new search or modify your existing search.



Command	Icon	Description
Find in Model View		Click this icon to find the selected search item in the Model View tree. This command is not enabled if the item isn't in the Model View (for example it is filtered, not shown, etc.).
Find in Active Diagram		This command finds and highlights the selected search item in the active diagram. This icon is enabled only if there is a diagram open and something is selected in the Search Results view.  If the selected search item is not found on the active diagram, a dialog opens telling you the element is not found. You are given the option to search for the element on other diagrams. If you click Yes, the Diagram Usage dialog opens.
Find in All Diagrams		This command searches for the selected search item on all diagrams in the model. The Diagram Usage dialog opens displaying all the diagrams where the element appears.
Open Property View		Opens the Property View for the selected search item. You can also open the Property View by right-clicking on the search item and selecting Properties.
Run Previous Search		Click the drop-down arrow on this icon to display the previous searches. The settings are included with the search name so you can remember what was searched. Up to ten searches are listed.
Filter Results		Opens the Search Results Filter dialog. Use this to refine the search. You can select which types of objects you don't want to see in the Results view. You can expand or collapse the tree. You can also select or deselect all the tree node items.

## Links

With a link you create a representation of a relationship between elements. These elements can consist of reference objects, data objects, and elements (including [lanes](#)) within a diagram. You can link the [Individual Elements](#) (attributes, columns, and data elements) contained in an External Data Objects.

Once you create links you can [edit](#) the link and create an [Impact Analysis Diagram](#) displaying the link relationships with source and target elements.

**NOTE:** When you create a link, the wizard creates a one-to-many relationship.

## Creating a link

- 1 In the Model View tree, right-click an element (i.e., project, model, pool, lane, or element) and select Links > New .

OR

On the main menu select Tools > Create Link and the Create Link Wizard opens for the selected element in the diagram.

OR

Right-click an element in the diagram and select Links > New to open the Create Link Wizard.

OR

Double-click the selected element to open its Property View. Select the Links tab and then click  to open the Create Link wizard.

**NOTE:** You can also [draw a link](#) between two elements by using the Link icon () on the Reference Objects palette.

- 2 In the Create Link dialog, you can specify the details for the new link:

Detail	Description
Target Elements	
Target Elements tree	Lists all available target elements. Only the elements appearing in the Model View tree and/or diagram are available to be selected. Select the target element(s) you want to link with your originally selected source element. The tree includes the following elements: Business Process Modeling, Conceptual Model, External Data Objects, Projects/Models/Data Sources, and Reference Objects.
Filter button	Click this button to select the types you want included in the list of Target Elements. You can include/exclude the following types: Business Process Modeling, Conceptual Modeling, External Data Objects, Reference Objects, Shapes, and Projects/Models/Data Sources.  You can click Restore Defaults)to reset all the values back to their original settings.  Once you make your selection and close the Filter dialog, the label for the Target Elements list box now indicates the list is filtered.
Expand All button	Expands all the nodes in the Target Elements list box.
Collapse button	Collapses all the nodes in the Target Elements list box.

Detail	Description
Link Properties	
Name	Enter the name for the link you are creating.
Verb Phrase	Type a verb phrase that describes the relationship from the perspective of the source. For example: EMPLOYEE "owns" RESUME. This label appears on the link where it connects to the source.
Inverse Verb Phrase	Type a verb phrase that describes the relationship from the perspective of the target. For example: RESUME "is owned by" EMPLOYEE. This label appears on the link where it connects to the source.
Description	You can enter a description of the link you are creating. A shortcut menu is available with the following commands: cut, copy, paste, delete and select all. The Undo command is also available. You can cut, copy and paste text from other applications and other dialogs to the Description text box.
Notes	You can enter additional information in this text field. A shortcut menu is available with the following commands: cut, copy, paste, delete and select all. The Undo command is also available. You can cut, copy and paste text from other applications and other dialogs to the Notes text box.

- Once you have specified all the details for the new link click OK. You can view this newly created link four different ways:

- Create an Impact Analysis diagram.
- Right-click either the source or target element in the diagram and select Connections > Show > Links.

**NOTE:** If you have created links between elements that exist in two different processes (for example, in two different diagrams in a workspace or in two different pools), the Show > Links command does not display those links.

- Click the Impact Analysis tab in the either source element, target element or link Property Views.
- The created link appears in the Model View tree as a separate folder. In the following example the subject area "Lending" has an outgoing "link" relationship to the subject area "Securities".

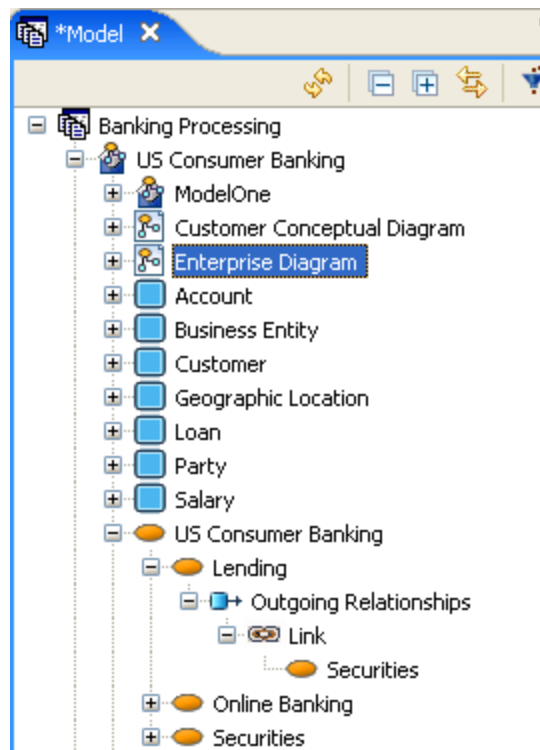

- 4 You can show the link label by right-clicking on the link and selecting Show > Name.
- 5 If you entered a Verb Phrase and/or an Inverse Verb Phrase you can also display them by right-clicking the link and selecting Show.

## Connecting links to lanes

You can also connect a link to a lane in a pool.

- 1 Click Link (🔗) on the Reference Objects palette.
- 2 Click on the object you want to connect to the lane and then click in the lane. The following rules apply as to where you click in the lane:
  - Draw the link directly to the Lane Header / Name Label to connect to the lane.
  - In order to connect to a lane, the link must be connected closer to the center or inner edge of the lane. Attempting to connect to the upper (or left) portion of the lane will connect to the pool instead.

The following example shows where you would need to click to connect to a lane. (note where the cursor is in the following illustration).

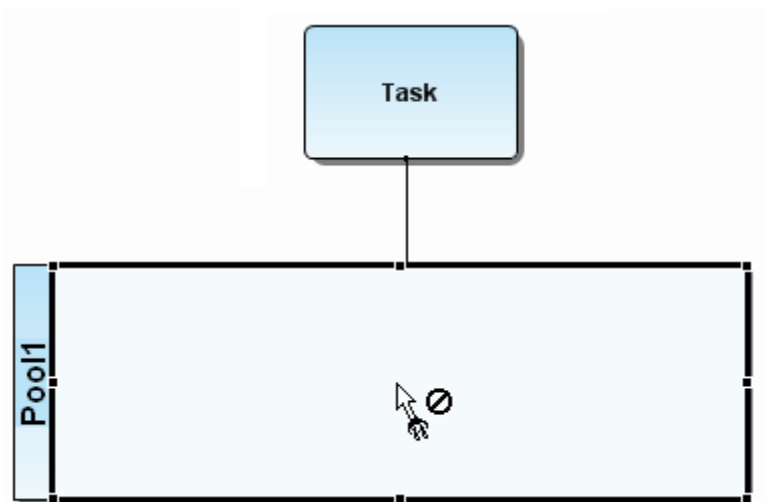

Once you click in the lane, the link connects to the border of the selected lane.

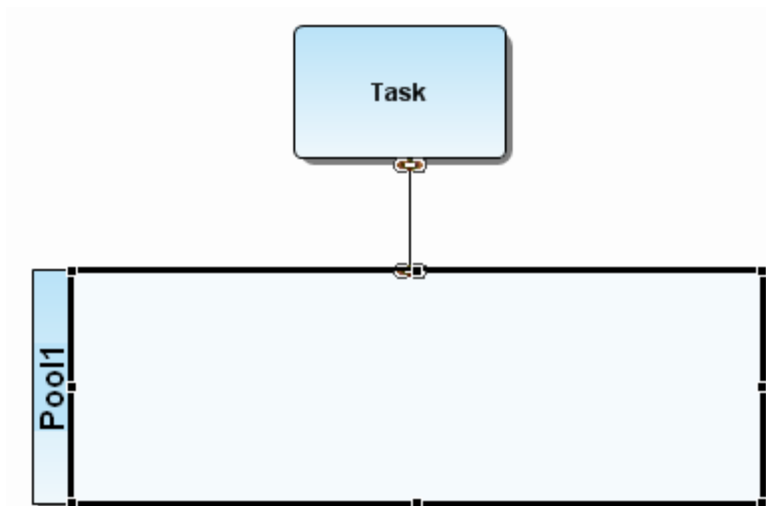

## Editing Links

You can edit links either through the Edit Links dialog or by using the Link's property view.



- 1 To open the Edit Links dialog, right-click the target element or source element in the model view tree and select Link > Edit. Select the link you want to edit from the pull-right menu displaying the name(s) of the links.
- 2 To open the property view, double-click the link you just created, either in the Model View or in the diagram, and the Property View for that [link](#) opens. You can edit the following properties of the link on the General tab.
- 3 The dialog box and the property view contain the same properties which can be edited. However, they are displayed in different formats. The following properties can be edited:

Name	Displays the names of the two linked elements.
Verb Phrase	Type a verb phrase that describes the relationship from the perspective of the source. For example: EMPLOYEE "owns" RESUME. This label appears on the link where it connects to the source.
Inverse Verb Phrase	Type a verb phrase that describes the relationship from the perspective of the target. For example: RESUME "is owned by" EMPLOYEE. This label appears on the link where it connects to the target.

- 4 You can add a description of the link in the Description tab of the Property View and add additional information under the Notes tab.
- 5 You can edit the target element by clicking  on the Source and Targets tab. The Property View for the selected element opens as a tabbed view.

## Drawing a link

Instead of using the Create Link wizard, you can create a link in the Diagram View using the link icon () in the Reference Objects palette or Reference Objects toolbar.

- 1 Click the drop-down arrow on the Reference Objects palette and select  Link, or select  from the Reference Objects toolbar.
- 2 Click the element that is the origination or source of the link.

- Click the element that you want the first element linked to (i.e., the target) and a link is created. Link icons are placed on the elements at the beginning and ending of the link.

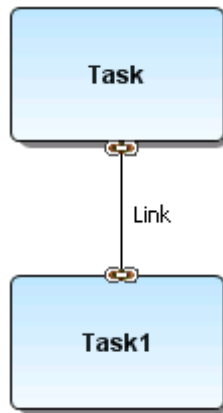

## Usages

You can show the create, read, update, or delete database attributes on a connection. When this connection is created they are labeled with the attributes you selected at the time of creation. These elements can consist of reference objects, data objects, and elements within a diagram. Once you [create](#) these usage indicators, you can [edit](#) and [export](#) the usage. You can also create an [Impact Analysis Diagram](#) displaying the created usage.

**NOTE:** When you create a usage, the wizard creates a many-to-one relationship.

### Creating a usage

- In the Model View tree, right-click an element (i.e., project, model, pool, lane, or element) and select Usage (CRUD) >  New.

OR

On the main menu select Tools > Create Usage and the Create Usage Wizard opens for the selected element.

OR

Right-click an element in the diagram and select Usage (CRUD) > New to open the Create Usage Wizard.

OR

Double-click the selected element to open its Property View. Select the Usage (CRUD) tab and then click  to open the Create Usage wizard.

**NOTE:** You can also [draw a usage](#) between two elements by using the Usage icon () on the Reference Objects palette.

2 In the Create Usage dialog, you can specify the details for the new usage:

Detail	Description
Target Elements	
Target Elements tree	<p>Lists all available target elements. Only the elements appearing in the Model View tree and/or diagram are available to be targeted.</p> <p>Select the element(s) you want to connect with your originally selected element.</p>
Filter Lists of Target Elements button	<p>Opens the Create Usage Target Element Filter. You can select the types you want included in the list of Target Elements. You can include/exclude the following types: Business Process Modeling, Conceptual Modeling, External Data Objects, Reference Objects, Shapes, and Projects/Models/Data Sources.</p> <p>You can click Restore Defaults () to reset all the values back to their original settings.</p> <p>Once you make your selection and close the dialog, the label for the Target Elements list box now indicates the list is filtered.</p>
Expand All button	Expands all the nodes in the Target Elements list box.
Collapse button	Collapses all the nodes in the Target Elements list box.
Link Properties	
Usage	<p>Create: Attribute indicating usage adds new records or entries.</p> <p>Read: Attribute indicating usage views existing records or entries.</p> <p>Update: Attribute indicating usage edits existing records or entries.</p> <p>Delete: Attribute indicating usage deletes existing records or entries.</p>
Description	You can enter a description of the link you are creating.
Notes	You can enter additional information in this text field.

3 Once you have specified all the details for the new usage click OK. You can view this newly created usage five different ways:

- Create an [Impact Analysis Diagram](#).
- Right-click either the source or target element and select Connections > Show > Usages.
- Right-click an element in the Model View and select Usage(CRUD) > Edit or View... and the Property View opens. Click the Impact Analysis tab for either one of the connected elements.
- The created usage appears in the Model View tree in either an Incoming Relationships or Outgoing Relationships node (depending on whether you selected the source or target element). In the following example the task "Task in Invisible Pool" has an outgoing "usage" relationship to the task "Task".



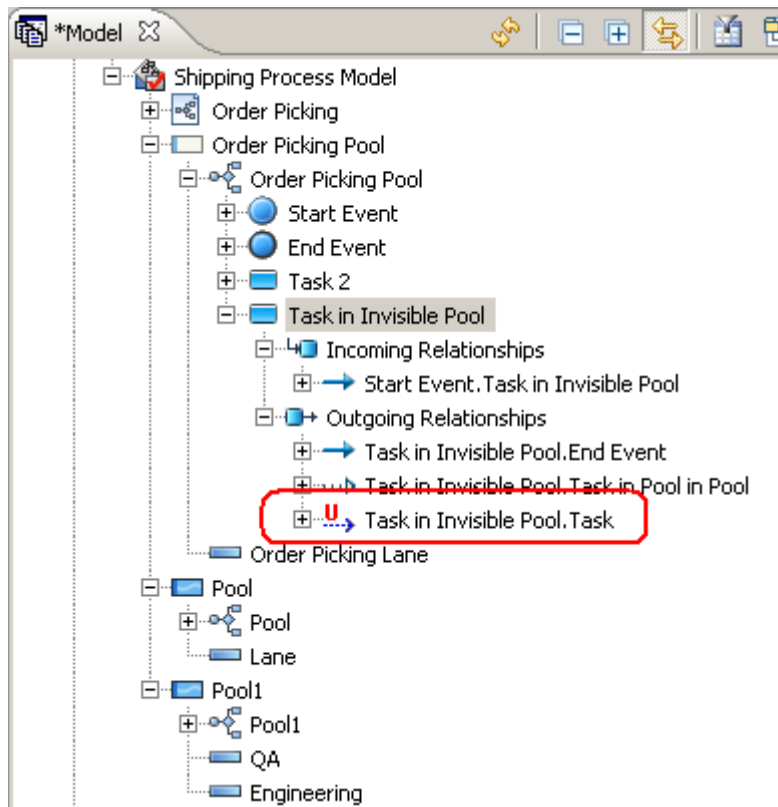

- 4 You can show the usage name by right-clicking on the link and selecting Show > Name.
- 5 The CRUD attributes are shown by default. You can hide these attributes by right-clicking on the Usage and deselecting the Show > Usage command.

## Editing usage

You can edit the names, attributes, descriptions and notes for usages by using the Usage (CRUD) property view.

- 1 Right-click the source element in the Model View tree and select Usage (CRUD) > Edit. The Property View for that element opens with the Usage (CRUD) tab displayed. This tab displays the receivers and their usage settings in the grid.
- 2 Select a receiver from the grid and click the Edit Usage . You can edit the name and usage settings for the selected usage under the General tab. You can also add or edit descriptions and notes.
 

**NOTE:** You can also double-click the usage you just created, either in the Model View or in the diagram, and you are taken directly to the Property View for the usage.
- 3 If you want to edit just the usage setting, select the receiver in the grid and press F2. This places you in an edit mode for that cell.

## Exporting a usage

You can export the Usage (CRUD) report from the Property View using four different formats: CSV, HTML, PDF, and RTF.

- 1 From the Model View or the diagram, double-click the source element of the Usage (CRUD) relationship to open the Property View. For example if you created a usage from "Task A" to "Task B", you would double-click on "Task A".
- 2 Click the Usage (CRUD) tab to open the report and click export icon ()

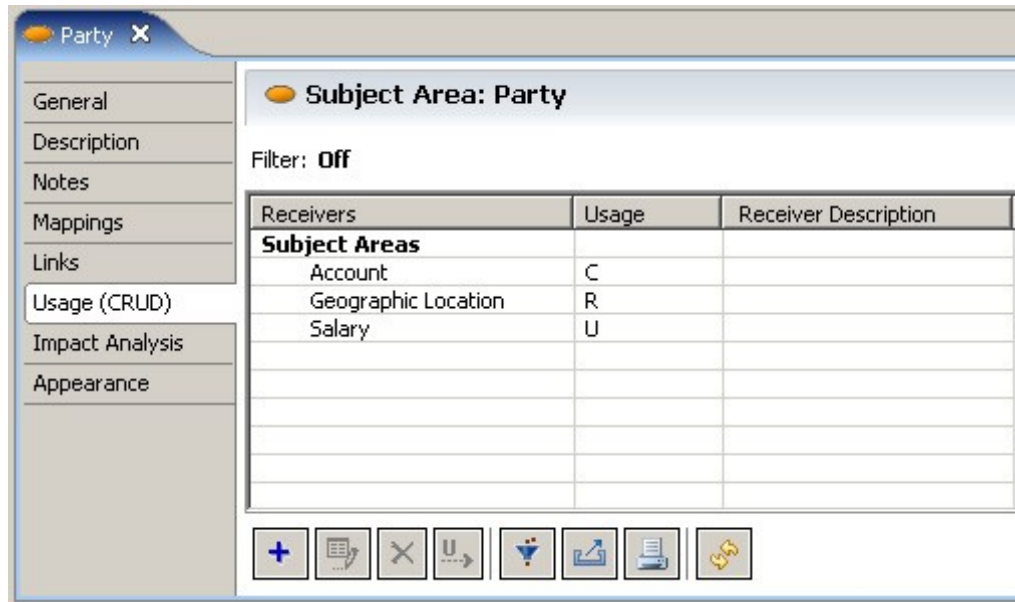



- 3 In the Export dialog export the folder location you want to save the report in. The default location is the current workspace folder.
- 4 You can use the default file name or rename it.
- 5 Select the type of report you want to generate: CSV, HTML, PDF, or RTF and click Save. A file is generated and the Export dialog closes.

- Open the folder where you saved the report and double-click to open it. The following example shows a report exported in the CSV format.

	A	B	C
1	Receiver Type	Receiver Name	Usage
2	Subject Area	Account	C
3	Subject Area	Geographic Location	R
4	Subject Area	Salary	U
5			
6			

## Drawing a usage

Instead of using the Create Usage wizard, you can create a usage in the Diagram View using the Usage () icon in the Reference Objects palette or Reference Objects toolbar.

- Click the drop-down arrow on the Reference Objects palette and select  Usage, or select  from the Reference Objects toolbar.
- Click the element that is the origination of the usage.
- Click the element that you want the first element connected to and a usage is created.
 

**NOTE:** The usage that is placed in the diagram has an editable text field containing the usage settings (C, R, U, D). You can change these settings in the text field.
- Right-click the usage and select Show > Name. The connection is labeled with the source and target name (for example "Lending.Securities").

- 5 You can set the usage type in the [Property View](#), which can be shown as well. In the following example the usage indicator is "R" for read.

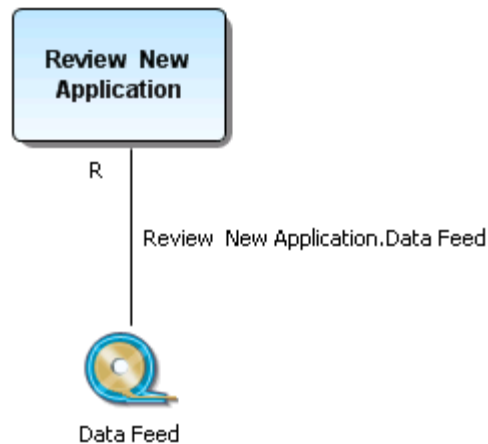

## Impact analysis diagram

Once you have created a link or usage, you can create an Impact Analysis Diagram displaying a graphical representation of those links. You can [update](#) an existing Impact Analysis diagram rather than generating a new one for the same element. The Impact Analysis Diagram can also be viewed as a [grid](#).

If a source object has been linked to an External Data Object Attribute, Column, or Data Element, they also will appear on the Impact Analysis Diagram. Their names are displayed as ParentName.Name in the view and are not editable in the diagram. You can double-click on them to open the associated Property View, where you can change their properties.

You can create an Impact Analysis Diagram several ways:

Right-click an element that you have created a link or usage for in the Model View tree and select Impact Analysis > Generate New Diagram....

OR

Right-click an element that you have created a link or usage for in the Diagram View and select Impact Analysis Diagram....



OR

Open the Property View for an element and click  in on the Impact Analysis tab.

OR

Select an element in the Model View tree or Diagram View and on the main menu select Tools > Generate Impact Analysis Diagram....

**NOTE:** You will get a warning dialog telling you that there may be a delay when generating large diagrams.

The created diagram appears as an additional tab in the Diagram View. It also appears in the Model View tree and is represented by the following icon: . You can save the diagram by clicking . You can also print this diagram by clicking  on the Standard toolbar.

The following example shows a sample Impact Analysis Diagram. The two tasks (Company and Employee) are linked and have both a verb phrase and an inverse verb phrase. The data object (Resume) shows a usage indicator connected to the Employee task and has a usage setting of "C" for create.

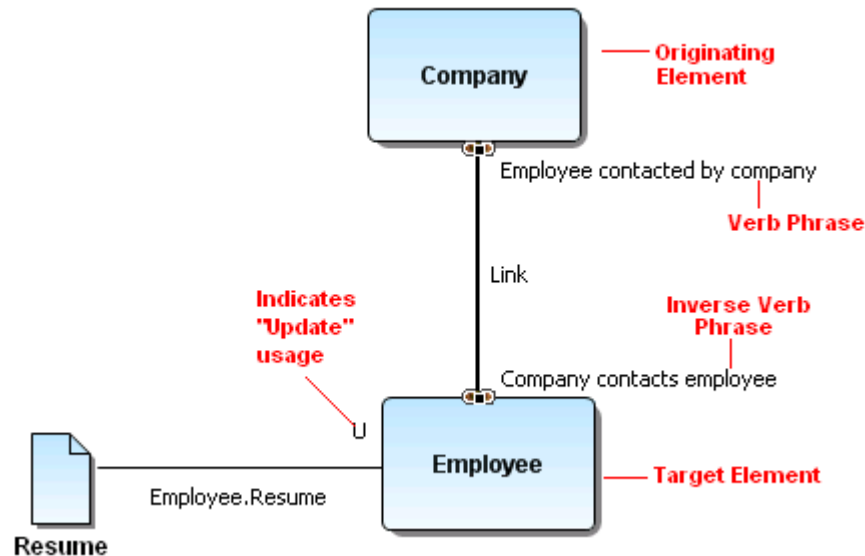

## Updating an Impact Analysis diagram

Instead of generating a new Impact Analysis diagram each time you add links or usages, you can refresh or update your existing diagram to show new connections.

Right-click in the background of an existing Impact Analysis Diagram in the Diagram View and click Update Impact Analysis.

OR

Right-click the Impact Analysis diagram node in the Model View and click Update Impact Analysis.

OR

Select the Impact Analysis diagram in the Model View and on the main menu, select Diagram > Update Impact Analysis.

**NOTE:** This menu option is available only if the Impact Analysis diagram is open and is selected on the Model View.

## View an Impact Analysis diagram in the Grid Editor

- 1 Right-click in the background of an opened Impact Analysis Diagram.

OR

Right-click on the Impact Analysis Diagram in the Model View.

- 2 Select Grid Editor.... The information now appears in a grid format with full editing capabilities.

For more information, see [Grid Editor](#).

## Grid Editor

The Grid Editor displays information about diagrams, reference objects data, or selected elements in a diagram in a spread-sheet format. The spread-sheet format allows you to enter a lot of information quickly. This Grid Editor is dynamic, reflecting changes made in the Model View tree or the Diagram view. When you [open](#) a Grid Editor it is placed in the Diagram View as a tabbed view and if a diagram is already open, it appears as an additional tab.

When you create a Grid, the Grid Editor displays all the element types in alphabetical order. The names of the elements are listed in alphabetical order under each element type as well. The following example shows some of the elements in a business process modeling diagram.

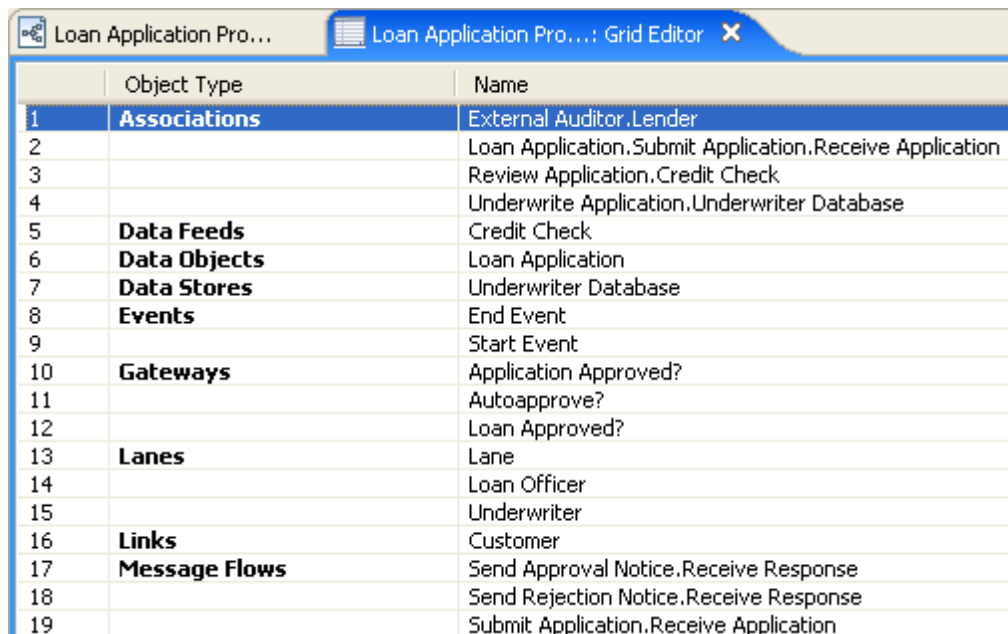

	Object Type	Name
1	<b>Associations</b>	External Auditor.Lender
2		Loan Application.Submit Application.Receive Application
3		Review Application.Credit Check
4		Underwrite Application.Underwriter Database
5	<b>Data Feeds</b>	Credit Check
6	<b>Data Objects</b>	Loan Application
7	<b>Data Stores</b>	Underwriter Database
8	<b>Events</b>	End Event
9		Start Event
10	<b>Gateways</b>	Application Approved?
11		Autoapprove?
12		Loan Approved?
13	<b>Lanes</b>	Lane
14		Loan Officer
15		Underwriter
16	<b>Links</b>	Customer
17	<b>Message Flows</b>	Send Approval Notice.Receive Response
18		Send Rejection Notice.Receive Response
19		Submit Application.Receive Application

The columns available depend on the node or elements selected. For example if you create a grid on the Steward Object node, there is a column labeled E-Mail Address. This information would not appear if you selected a diagram node. You can choose to hide/show columns from within this common subset as described in the [Customizing the Grid Editor](#) section.

The following table lists all the elements and the information that appears for each:

Element	Available Columns
Business Process Modeling Elements	
Associations Message Flows Sequence Flows	Name Description Notes
Events Tasks Pools/Lanes Gateways	Name Description Notes
Data Object Group Annotation Off-Page Connector	Name Description Notes
Conceptual Modeling Elements	
Subject Area Business Entity Business Attribute Interaction Relationship	Name Description Notes
Reference Objects	
Business Element	Name Data Type Description Notes
Business Rule	Name Type Description Notes
Business Unit	Name Description Notes
Stewards	Name Type E-Mail Address Responsibility Description Notes
External Data Objects	

Element	Available Columns
Data Feed Data Store Entity Flat File Report Table View	Name Description Notes
Drawing Shapes	
All Shapes	Name Parent (Parent Type) Description Notes

## Opening the Grid Editor

Right-click a node in the Model View tree and select Grid Editor.

OR

Select an item in the Model View tree and select Tools > Grid Editor from the main menu.

**NOTE:** If a filter has been set in the Model View tree node, this filter also applies to the Grid Editor.

The following nodes have the Grid Editor option available:

Node	Description
Model	Displays all elements contained in the selected model.
Diagram	Displays all items contained in the diagram.
Elements	Displays information for the element and all items contained in that element. For example, if you right-clicked on a business entity, all the business attributes will be listed as well. Relationships for the selected element are listed also.
Business Element/ Business Rule/Business Unit/Steward nodes	Displays the elements, rules, units, and stewards that you have created. within their related folder. For example all business rules created are listed in the Grid Editor when you right-click on the Business Rules node. However, when you right-click on a created business rule within that folder, the Grid Editor is not available.
External Data Objects node	Displays all the external data objects you have created or added in the current workspace.



## Using the Grid Editor

It is easy to [navigate](#) in the Grid Editor. All items on this Grid Editor are [editable](#) and can be [sorted](#). There is a quick and easy way to [enter](#) large amounts of reference object data in the Grid Editor. That data can then be [imported](#) into another grid editor. You can [print](#) or [export](#) the Grid Editor, and [customize](#) what columns appear.

### Navigating

- When a cell is selected, Tab moves you forward and Shift+Tab moves you backwards among the populated cells in a row. If you continue to tab at the end of a row, you advance to the first cell in the next row.
- When a cell is selected and you press Enter, you move down a row to the cell directly below the selected cell. For example, if you select the cell in the Name column, pressing *Enter* moves you to the Name column in the next row. You remain in edit mode until you press *Esc* or click another row.
- When a row is selected and you press Enter, you move down to the next row. When there are no more rows, then the first row in the Grid Editor is selected.
- While a row is selected, you can use the up/down arrow keys to navigate between the rows. Pressing F2 puts you in the edit mode for the name.

### Editing

You can edit the text in the Grid Editor in two ways:

- In-line editing: Click once to select the row and then click again to put the cell you want to edit in edit mode.
  - TIP:** If a cell is in the edit mode, you cannot use the right/left arrow keys to move the cursor within the text field unless you press F2.
- Property Editor: To launch the Property View for an item double-click on a row, press Alt+Enter, or right-click in the row and click Properties. Changes made in the Property View are reflected in the Grid Editor when completed.

You can also cut, copy and paste in the Grid Editor.

- 1 Click once to select the row and then click again to put the cell you want to edit in edit mode. You can also press F2.
- 2 Right-click the selected cell and select either cut or copy. You can then paste a cut or copied cell into another cell or in a selected third-party applications like Microsoft® Word or Microsoft® Excel.
- 3 You can also copy or cut text from a third-party applications like Microsoft Word or Microsoft Excel and paste it into a selected cell in the Grid Editor.

## Sorting

The default sorting is alphanumeric by name, within a type. When you double-click on a column header the sorting toggles between ascending or descending order (within the type nodes). The direction of the sort is indicated by a directional arrow in the column header.

## Printing

You can print the current Grid Editor.

- 1 With the Grid Editor open and active, select File > Print from the main menu, click  on the Standard Toolbar, or press Ctrl+P.
- 2 In the Print dialog select the options you want and click Print.

## Using the Grid Editor for entering reference objects data

The Grid Editor provides a fast and simple means of entering large amounts of data for Reference Objects.

- 1 In the Model View tree, right-click on one of the Reference Object subnodes (for example Business Elements).
- 2 Select Grid Editor and the Grid Editor opens.  
**NOTE:** If no reference objects exist, the first row is blank. If reference objects already exist for the selected node, the blank row appears at the end of the existing objects.
- 3 When you select the blank row, the Name text field becomes editable. Enter the element name and tab to the Data Type cell.
- 4 You can select one of the data types from a drop-down list. The list of data types depends on the type of reference object you are creating.
- 5 Tab to the Description cell and enter any descriptive text. You can also add additional information in the Notes column.
- 6 When you tab again you are automatically taken to the next blank row where the Name cell is editable.  
**NOTE:** A newly created Reference Object element now appears in the Model View tree under the selected subnode.
- 7 You can quickly navigate through the rows. Each time you press Enter you advance down one row. When you reach the last row, you are returned to the first row.



## Exporting the Grid Editor

You can export the Grid Editor in the following formats:

File Type	Description
csv	Comma separated text file
html	Hypertext Markup Language
pdf	Adobe Acrobat
rtf	Rich Text Format

- 1 Open a Grid Editor or select a Grid Editor that is already open in the Diagram view.

Select File > Export > Grid Editor from the main menu or click  and the Export dialog opens. The default folder is the current workspace.

- 2 Name the file, select the file type from the drop-down menu and click OK. The exported file is saved in the selected folder.

**NOTE:** When exporting the Grid Editor in the pdf file format, the column widths are set relative to their actual width in the application.

## Importing data exported from the Grid Editor

You can import Comma Separated Value (CSV) files containing Reference Objects that you have exported from a Grid Editor. This function is useful when you have many Reference Objects of a certain type that you want to use in another workspace or make available to another user. You can export that information and then make it available to be imported without the burden of re-entering the data.

The exported CSV files from ER/Studio BA can only contain one type of exported Reference Object. For example, you could export all your Business Rules contained in a workspace and your exported file would only contain those Business Rules. Once imported, these objects are placed in the appropriate folder (i.e., Business Rules) in the Model View tree.

- 1 Open the workspace where you want to import the csv file.
- 2 Choose File > Import > Comma Separated Values (CSV)... from the main menu

OR

Right-click the Reference Object node where you want to place the imported objects and select Import Comma Separated Values (CSV)....

The CSV Import Wizard opens.

- 3 Select the object type you want to import from the Available Object Types list. This object type must match the object types you exported.
- 4 Browse to the location of the previously exported Grid Editor file and select the file you want to import.

5 Click OK and then click Next.

- If there are elements that exist with the same name the Possible Duplicate Elements dialog opens. You can choose to create a new element with a unique name or update the existing element. When updating existing elements the following will occur: (1) Elements in the project having corresponding objects in the import are updated with new information; and (2) Objects in the import without corresponding element in the project are added to the project as new element.
  - If there are problems with the import, a Problems in File dialog opens. A table lists any errors, warnings, or information, as well as the line number of the problem.
    - Click Launch Editor to open the application associated with the CSV extension, where you can view and correct any problems.
    - Once you have corrected the problem click Revalidate.
- 6 If the import is successful, an Import Summary dialog opens displaying all the records that have been imported.
- 7 Click Finish and a CSV Import Complete notification dialog opens telling you how many elements were created in ER/Studio BA.
- 8 Once you close the notification dialog, the imported elements are placed under the appropriate node in the Model View tree.
- 9 You can then drag these elements on to an existing diagram. When you double-click on an element, the Property View for that element opens displaying the imported data.

## Customizing the Grid Editor

You can customize the Grid Editor to display only selected columns.

- 1 Open a Grid Editor in the application.
- 2 Right-click in the Grid Editor and select Customize Columns.... All columns are displayed by default.
- 3 In the Customize Columns dialog, deselect the columns you want to hide in the view and click OK.
- 4 The selected columns no longer appear and the tab displays the notation that you have customized this Grid Editor.

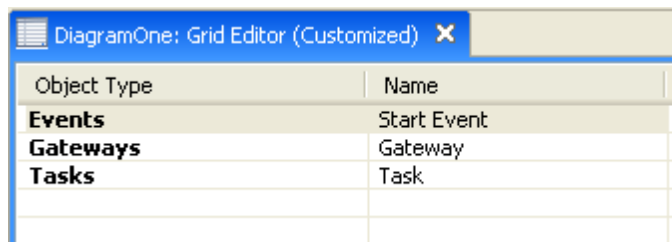

Object Type	Name
<b>Events</b>	Start Event
<b>Gateways</b>	Gateway
<b>Tasks</b>	Task

## Reports

There are two main reports in the ER/Studio BA application: The [Impact Analysis Report](#) and the [Web Report](#). If your installation also encompasses ER/Studio Repository, you can view and create many different reports through ER/Studio Portal. For more information, see the *ER/Studio Portal User Guide*.

### Impact Analysis report



The Impact Analysis Report exists for most elements in the Model View tree. As you make changes to an element this report is updated dynamically. For example, if you add a link, that link and its target are immediately displayed in the report.

You can gain access to these reports by double-clicking on any element in the tree to open the Property View. Once the Property View for the selected element is open, click the Impact Analysis tab.

You can also open the Impact Analysis Report by selecting an element in the tree and choosing Tools > Reports > Impact Analysis....

Impact Analysis Reports can be [printed](#) or [exported](#). You can also [filter](#) the report so only selected elements are shown.

This report shows the following interrelationships between elements:

Main Category	Definition
Workspace Hierarchy	Displays the workspace, projects, and models associated with it.
Diagram Usage	Displays all diagrams the element is in. This includes any generated Impact Analysis Diagrams, which include graphical representations of all links and usages on a diagram.
Heritage	Displays the parent and/or children of the selected element.
Incoming and Outgoing Connecting Objects	Displays all connecting objects for the selected element, including the type of connection, and the origination and termination of the connection.
Links	Displays all links (  ) for a selected element and the name of the element where the link terminates.  You are also given information on whether the current element is the source or the target of a link.
Usages	Display all usages (  ) for a selected element and the name of the element where the usage terminates.

#### Using the Impact Analysis filter

In the Impact Analysis report, click  to open the Impact Analysis Filter dialog. There are two tabs: [Setting Relationship Types](#) and [Setting Object Types](#). The status of the filter (on or off) is displayed in the header of the Impact Analysis report.

#### Setting relationship types

You can select the types of relationships you want included in the impact analysis. You can select an entire level, for example, Heritage. Or you can select lower levels such as Parent, which is a subset of Heritage.

## Setting object types

All object types are listed in a collapsed list under this tab. Click  to view all types associated with a selected heading. You can select the entire group or select individual elements within that group.

## Using the Text Filter option

If you only want objects with a certain name or by a certain alpha character to appear in the tree:

- 1 Click  to open the Impact Analysis Filter dialog.
- 2 Select the Text Filter icon and the text box is now available.
- 3 Enter the name you want to base the filter on. There are several different options:
  - If you enter an alpha character followed by an asterisk, all elements with the entered alpha character will appear in the tree. For example, if you entered "T\*" in the text box, elements shown would include not only "Tasks" but "My Tasks" as well because a space is used in the name.
  - Also shown are elements that are connected to an element with the selected criteria. For example, if you have a gateway labeled "GateOne" connected to a sequence flow named "To Task One", if you have filtered on "T\*", both the gateway and the sequence flow appear in the Model View tree.
  - Also, you can enter an alpha character followed by a question mark as a single character "wild card" search. For example, if you entered "T?sk" the filter would show all names beginning in "T" and ending with "sk" in the Model View tree.
- 4 Once you have entered the text string you want searched on, press Enter and the Impact Analysis tab opens with the filtered selection.

## Exporting the Impact Analysis report

You can export the report in the following formats:

File Type	Description
csv	Comma Separated Value text file
html	Hypertext Markup Language
pdf	Adobe Acrobat
rtf	Rich Text Format

- 1 In the Property View, click  and the Export dialog opens. The default folder is the current workspace.
- 2 Name the file, select the file type from the drop-down menu and click OK. The exported Impact Analysis Report is saved in the selected folder.

## Printing the Impact Analysis report

- 1 In the Property View select the Impact Analysis page and click .
- 2 In the Print dialog select the options you want and click Print.

## Web report

ER/Studio BA offers a Web report feature that lets you generate a series of Web pages detailing key information about your workspace. This read-only report contains information about both Conceptual Model and Business Process Diagrams.

To create this report, you must complete the Web Report wizard. Web reports are ideal for adding to organizational intranets to quickly disseminate the latest information about the state of your projects. This section of help describes how to:

- [Create a Web report](#)
- [Use a Web report](#)

### Creating Web reports

ER/Studio BA offers an extensive HTML reporting feature you can use to display and review your projects online. To execute this feature, you must complete the [Web Report Wizard](#), which allows you to filter, set descriptions and set a location of the reports. Once executed, the wizard produces reports for each project and model stored in their own subfolder, which is named for the project/model they represent.

### Web Report wizard

You can generate a report on all information in the opened workspace using the Web Report Wizard. You can generate separate web reports for individual models as well as individual diagrams. The reports are created in the HTML format.

- 1 Choose Tools > Reports > Web Report from the main menu and the Web Report wizard opens. The first panel lists the following:
  - The current workspace
  - Reference Objects
  - External Data Objects
  - All related projects
  - All related models
  - All related diagrams

All items are selected by default.

**NOTE:** Only reference objects in the diagrams are included in the Web Reports. Reference Objects that exist only on the tree are not included in the report.

- 2 Deselect the items you don't want included in your web report and click Next.

**NOTE:** If a diagram is selected, the model elements are filtered based on the selected diagram.



- 3 In the Object Type Selection list box, specify the types of objects you want to include in the report. The following categories are available: Business Process Modeling, Conceptual Modeling, External Data Objects, Reference Objects, and Shapes. All items in this list box are selected by default. You can expand the categories and include/exclude individual elements within that category.
- 4 Click Next to the Select Report Location dialog. Select a directory where you want the report to be created. The default setting for the generated report is a folder named Web Reports under the workspace directory (...My Documents\ERStudioBusinessArchitect\Web Reports). The default web report name is the same as the currently opened workspace. You can also browse to a new directory, if you don't want to use the default.

**NOTE:** If you have already created a web report for your current workspace, you will get a warning that a report already exists in the specified location and that files will be overwritten.
- 5 If you selected the [preference](#) to launch the report upon completion, the "Launch report upon completion" option is already selected in the Web Report dialog.
- 6 Click Next to open the Report Details dialog. The Title and Author fields can be edited. You can also enter a description of the report. These details are displayed on the first page when the report first opens.
- 7 Click Finish and a progress information dialog opens telling you the reports are being generated.
- 8 Once the report has been generated a title page opens, as well as a tree displaying the workspaces, projects, models, diagrams, elements, reference objects, and external data objects. This tree is located on the left-hand side of the window.

You may get an Information Bar dialog warning you when Internet Explorer blocks a pop-up window. Click OK to close this dialog. Click once in the yellow bar with the warning icon (  ) and select Allow Blocked Content from the menu. Click Yes once again to close the Security Warning dialog.
- 9 Expand the tree and click on any diagram node to display a graphical representation of the diagram.
- 10 Click on an element and the report displays the element's properties. For example a business entity named Account in a conceptual model diagram is displayed as CMBusiness Entity: Customer Support.

## Using Web reports

When you use ER/Studio BA to create an HTML Web report, the application produces a folder for the workspace and all associated projects, models, diagrams, and elements.

- 1 In the left pane, click the name of any diagram and the Web Report displays a graphic of that diagram in the right pane.
- 2 Click any element in the tree and the Web Report displays, in the right pane, the element's properties in a tabular format.
- 3 Where applicable, a link is provided to a related element. For example, in the following graphic, the lane labeled "Underwriter" is a child of the pool "Lender".

The screenshot displays the ER/Studio Business Architect interface. On the left, a tree view shows the project structure. The 'Lender' pool is expanded, and the 'Underwriter' lane is selected and highlighted with a red box. On the right, two detail tables are shown for the selected elements.

### Underwriter (Lane)

Name	Underwriter
Parent pool	<a href="#">Lender</a>
Parent lane	

---

### Loan Officer (Lane)

Name	Loan Officer
Parent pool	<a href="#">Lender</a>
Parent lane	

- 4 When you click on the hyperlink “Lender”, the web page for that element opens, displaying the details for that pool.

The screenshot shows the ER/Studio Business Architect interface. On the left, the Model View tree is expanded to show the 'Lender' element, which is highlighted with a red rectangle. The right-hand pane displays the details for the 'Lender' pool.

## Lender (Pool)

### Details

Name	Lender
Participant	<a href="#">Participant2</a>
Process	<a href="#">Lender</a>
Boundary visible	True

### Lanes

<a href="#">Underwriter</a>
<a href="#">Loan Officer</a>

## Views

Views provide alternative presentations as well as ways to navigate the information in ER/Studio BA.

Views have their own menus. To open the menu for a view, click the icon at the left end of the view's title bar. Some views also have their own toolbars. The actions represented by buttons on view toolbars only affect the items within that view.

ER/Studio BA offers six main views in the application. Each view can be [opened](#), and [moved and docked](#) in a different location. And each view has a set of [icons](#) in the toolbar that makes it easy to manipulate the view.

The table below lists the five views:

Topic	Description
<a href="#">The Diagram View</a>	The Diagram View, located to the right of the Model View tree, is where you can place the graphical representations of the Business Process Modeling Notational and Conceptual elements as well as elements from the other palettes.
<a href="#">The Model View</a>	The Model View tree displays the hierarchy of workspaces, projects, models, diagrams, and elements. It also displays the hierarchy of reference elements. Workspaces, projects, models, diagrams, and elements can be created, organized, and viewed.

Topic	Description
<a href="#">The Palette View</a>	The Palette View contains the business process elements, conceptual elements, reference objects, external data objects, and drawing shapes elements used to create business process modeling diagrams in the Diagram View.
<a href="#">Error Logging View</a>	The Logging Views include the Error Logging view. This view tracks errors generated by ER/Studio BA.
<a href="#">Help View</a>	The Help View displays dynamically generated help topics.
<a href="#">Overview Window</a>	The Overview window is a scalable window displaying any diagram in its entirety.
<a href="#">Search Results</a>	Shows the results of a <a href="#">Search</a> of the metadata for a workspace.

### Opening a View window

- 1 On the Window menu, select Show View.
- 2 From the pull-right menu, select the view you want to open.

### Moving and Docking views

You can change the location of a view:

- 1 Drag the view by its title bar to the desired location. But do not release the left mouse button yet.

As you move the view around the Workbench, the mouse pointer changes to one of the [drop cursors](#). The drop cursor indicates where the view will be docked if you release the left mouse button.

**NOTE:** The drop cursor changes as you drag the view over the left, right, top, or bottom border of another view or editor.

- 2 When the view is in the location that you want, release the left mouse button to dock the view.







**NOTE:** A group of stacked views can be dragged using the empty space to the right of the view tabs.

You can also move a view by using the pop-up menu for the view. (Left-click the icon at the left end of the view's title bar, or right-click anywhere else in the view's title bar).







## Using drop cursors

The table below shows the different drop cursors and where the view will be moved to:

Drop Cursor	Where the view is moved to:
	The view is docked above the view underneath the cursor.
	The view is docked below the view underneath the cursor.
	The view is docked to the right of the view underneath the cursor.
	The view is docked to the left of the view underneath the cursor.
	The view is docked as a Tab in the same pane as the view underneath the cursor.
	This area is restricted and you cannot dock a view here.

## Using the Views toolbar

Each View window has a set of icons that allow you customize the view windows. You can use a drop-down menu to gain access to view tools, and you can minimize or maximize each view window.

Toolbar Icon	Element	Description
	Menu	Displays a drop-down menu containing all the toolbar icons for the selected window.
	Minimize	This command hides the view and only the icon and tab representing the view are displayed in the application window. Click once in the tab to restore the view to its original size and location.
	Maximize	The view is expanded to fill the entire application window.
	Restore	Once you have maximized a view window, the Restore icon appears in the upper right corner of the window. Click this icon to restore the maximized window to its original size.

## Diagram view

The Diagram View, located to the right of the Model View tree, is where you can place the graphical representations of the Business Process Modeling Notational elements, Conceptual elements, Reference Object elements, External Data Object elements, as well as elements from the Drawing Shapes palette. Each time you [place](#) an element in this area, it also appears in the Model View tree.

### Displaying the Diagram view

The Diagram View is not displayed when you first open a workspace in the application. The diagram node appears in the Model View tree, but the actual Diagram View is closed. To display this area, do the following:

- 1 In the Model View tree, right-click the diagram name node.
- 2 Select Open and the Diagram View opens, including the Business Process or Conceptual Objects, Reference Objects, External Data Objects, and Drawing Shapes palettes.

## Modifying the Diagram view



You can modify, position, and size the Model View. When you right-click the Model View tab, a shortcut menu opens displaying the following commands:

Command	Description
Restore	Restores a maximized window to its original size within the application.
Move	You can move a single view or an entire tab group. When you select this command, the select view or tab group is outlined with a gray box. Move the gray box to a selected location and click once. The view or tab group is placed in the new location.
Size	You can the resize the top, bottom, left or right side on a view. Click <b>Size</b> and then select one of the four available sides. The selected side is replaced by a wide bold line. Place the cursor on this line and the cursor changes to resize. Hold down the mouse button and move the side to the desired location.
Minimize	Hides the view and only the icon and tab representing the view are displayed in the application window. Click once in the tab to restore the view to its original size and location.
Maximize	The view is expanded to fill the entire application window.
Close	Closes the selected view. You can also click  located in the tab to close the view.
Close All	Closes all the views.
Close Others	Closes all views except the active view.
New Editor	Opens a new editor.

## Using the Diagram view

Once you have [created](#) a diagram in the Model View tree, you can design models using the notation elements available on the [palette](#).

- 1 On the palette click the element you want to place in the Diagram View.
- 2 Click in the area to place an element. Each element placed in the Diagram View also appears on the Model View tree.

**NOTE:** The cursor is in the multi-drop mode  so you can place as many elements as you need. Press ESC to exit the multi-drop mode. The cursor changes from  to .

For more information, see [Using Diagram Elements](#).

## Model view

The Model View appears in the upper left portion of ER/Studio BA by default. It contains the Model View tree displaying the hierarchy of workspaces, projects, models, diagrams, and elements. It also displays the hierarchy of reference elements. Workspaces, projects, models, diagrams, and elements can be created, organized, and viewed. You can modify the Model View to fit your preferences.

The Model View is easy to [use](#), allowing you to create and view all aspects of the application. The [Model View Toolbar](#) contains tools you can use to organize and filter the tree.

### Displaying the Model view

By default, the Model View is displayed when you first start the application. To display the Model View when hidden, do the following:

- 1 On the Window menu, select Show View.
- 2 Select Model from the pull-right menu.

### Modifying the Model view

You can modify, position, and size the Model View. When you right-click the Model View tab, a shortcut menu opens displaying the following commands:

Command	Description
Detached	Click this command to detach the view from the application's frame and position it anywhere within or outside the application window. This state of detachment is called floating. This is a toggle command and the Detached command is checked once it is selected.
Restore	Restores a maximized window to its original size within the application.
Move	You move a single view or an entire tab group. When you select this command, the select view or tab group is outlined with a gray box. Move the gray box to a selected location and click once. The view or tab group is placed in the new location.
Size	You can the resize the top, bottom, left or right side of a view. Click Size and then select one of the four available sides. The selected side is replaced by a wide bold line. Place the cursor on this line and the cursor changes to resize. Hold down the mouse button and move the side to the desired location.
Minimize	This command hides the view and only the icon and tab representing the view are displayed in the application window. Click once in the tab to restore the view to its original size and location.
Maximize	The view is expanded to fill the entire application window.
Close	This command closes the selected view. You can also click  located in the tab to close the view.



## Using the Model view

The Model View tree displays the [hierarchical](#) representation of all elements in a model. When you [create a new element](#) in the Model View, it does not appear in the Diagram View. Once you have created it, you can then drag that element onto the Diagram View. Each element in the Model View tree has a representative [icons](#).

**NOTE:** When you place an element in the Diagram View, a representative icon is automatically placed in Model View tree under the corresponding diagram node.

## Model view hierarchy

Elements appear under the model two different ways.

- An element appears under the Diagram Node as a presentation element. This is indicated by an arrow symbol placed on the element icon (📌). Incoming and Outgoing Relationship nodes are also shown.

**NOTE:** If you have chosen to hide a connection using the Hide command from the shortcut menu in the Diagram, the connection node appears greyed out in the Diagram Node. Also, when you float your cursor over the hidden node the Tooltip displays the information that it is "hidden".

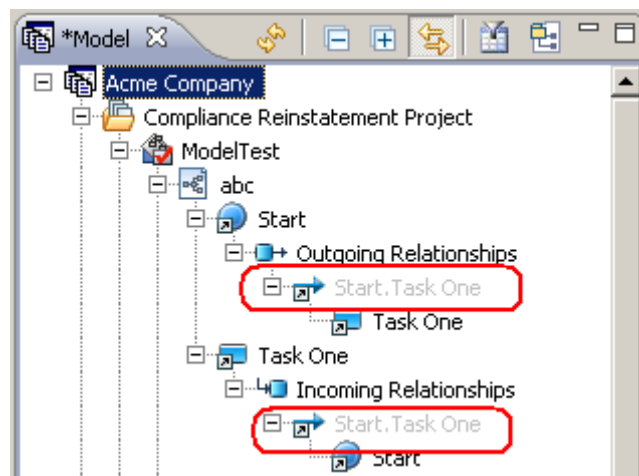

- The second means of display depends on whether you are creating Business Process Modeling diagrams or Conceptual Model diagrams.
- If you are creating Business Process Modeling elements, all elements are placed either below the [Process](#) node, or a pool node. In the following example, the diagram contains a pool with an invisible boundary (named Order Picking Pool) and is indicated by the 📌 icon in the Model View tree. The lane, named Order Picking Lane, is "owned" by the pool. The event is owned by the process, but since the process is hidden, it appears under the pool.

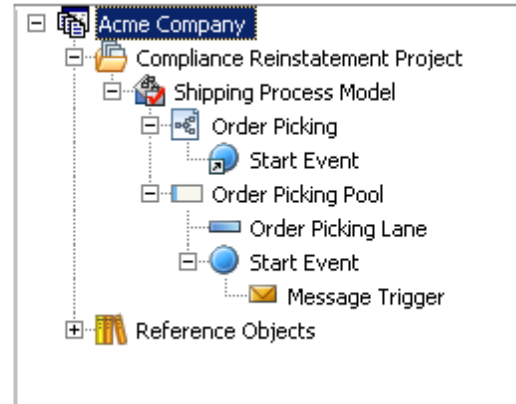

- If you are creating Conceptual Modeling elements, all elements are placed below the model node.

**NOTE:** You can also display elements [grouped by object type](#).

The table below describes the different nodes in the Model View tree:

Node	Icon	Description
Workspace		Top-level node containing all projects, models, diagrams, and reference objects. You can only have one workspace open at a time in the Model View.
Project		The project is associated with the workspace and is nested one level below the workspace.
Conceptual Model		The Conceptual Model contains diagrams and elements associated with the Conceptual Model type.
Business Process Model	The Business Process Model node can have two different icons depending on the <a href="#">validation</a> setting you select.	
		Non-Validated: If you select Off, a Non-Validated icon is displayed.
		Validated: When you select On, the Validated icon is displayed.
Diagram		When you expand the diagram node, presentation elements in the diagram are listed.
Impact Analysis Diagram		When you expand this node, all elements in the Impact Analysis diagram are listed.
Pool with Invisible Boundary		A pool and lane with an invisible boundary are created when first create a diagram.
Elements	There are two different representations of elements in the Model View tree: Regular and Presentation. When you expand an element, associated elements are then displayed, including incoming and outgoing relationships.	
		Regular: If the element does not display the directional arrow, it means that it represents the metadata.
		Presentation: When elements are displayed under the diagram node, each icon includes a shortcut decorator. This indicates it is a presentation element only, representing an element on a diagram.
<a href="#">Reference Objects</a>		Top-level node containing all reference elements for the current workspace: External Data Objects, Business Rules, Business Units, and Stewards.







## Model view icons

Listed below are all the icons used in the Model View tree:

Icon	Description
	Workspace
	Project
	Conceptual Model
	Business Process Model - validation on
	Business Process Model - validation off
	Business Process Diagram
	Conceptual Model Diagram
	Process Node
	Impact Analysis Diagram
	Each modeling element is represented by an icon in the tree.
	If the element is a presentation element only it includes a shortcut decorator.
	When the elements are grouped by type, the element icons display a folder indicator.
	Incoming Relationships
	Outgoing Relationships
	Link - Represents links created using the Create Link Wizard.
	Usage - Create usages using the Create Usage Wizard.
	Reference Object - External Data Objects
	Reference Object - Business Element
	Reference Object - Business Rules
	Reference Object - Business Units
	Reference Object - Stewards

## Model view toolbar

You can use the icons on this toolbar to refresh, filter, and navigate through the Model View tree. You can also synchronize with a diagram, and group by element type.

Toolbar Icon	Element	Description
	Refresh the Entire Model View	Updates all the nodes in the Model View tree.
	Collapse All	Collapses the tree expansion of all the resources in the view.
	Expand All	Expands all the nodes in the tree including all diagrams.
	Sync with Diagram	If this command is selected, whenever an element in the Model View tree is selected, that element is selected in the diagram. The sync option is on by default.  <b>Note:</b> Right-click on an element in a diagram and select the command "Find in Model View" to locate an element in the Model View tree.
	<a href="#">Model View Filter</a>	Opens the Model View Filter dialog.
	<a href="#">Grouping by Object Type</a>	Groups items in the Model View tree by element type. This is a toggle switch.

### Model view filter

You can use this filter to hide or show business process modeling elements, conceptual elements, reference objects, data objects, and drawing shapes in the Model View tree. When you click , the Model View Filter dialog opens. You can filter out elements based on a general type, or a specific element. A status bar located in the lower right-hand corner of the application displays the status of the filter (off or on). Also, if the filter is in use, it is indicated on the Model View tab.

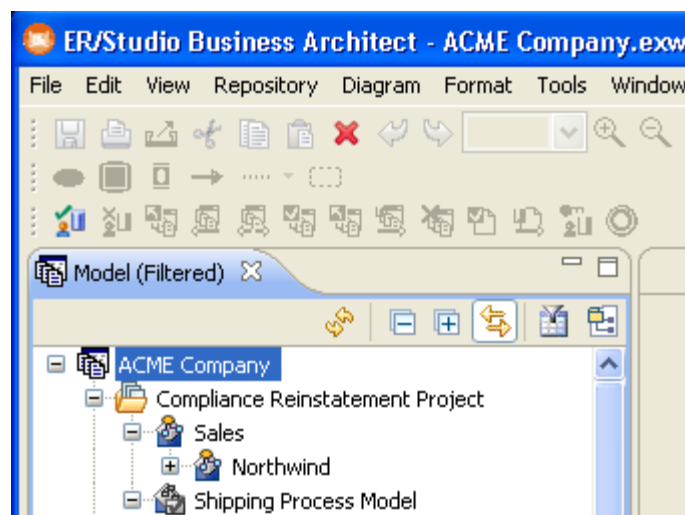

**NOTE:** If you want to hide the Incoming Relationships grouping node, clear the checkboxes of all the connecting objects in the filter.

## Using the Text filter option

If you only want elements with a certain name or by a certain alpha character to appear in the tree:

- 1 Click  to open the Model View Filter dialog.
  - 2 Select the Text Filter icon and the text box is now available.
  - 3 Enter the name you want to base the filter on. There are several different options:
    - If you enter an alpha character followed by an asterisk, all elements with the entered alpha character will appear in the tree. For example, if you entered "T\*" in the text box, elements shown would include not only "Tasks" but "My Tasks" as well because a sCspace is used in the name.
    - Also shown are elements that are connected to an element with the selected criteria. For example, if you have a gateway labeled "GateOne" connected to a sequence flow named "To Task One", if you have filtered on "T\*", both the gateway and the sequence flow appear in the Model View tree.
    - Also, you can enter an alpha character followed by a question mark as a single character "wild card" search. For example, if you entered "T?sk" the filter would show all names beginning in "T" and ending with "sk" in the Model View tree.
- NOTE:** The text filter is not case-sensitive. For example if the object name is "JOE", both "joe" and "JOE" would be the filter for that object.

## Grouping by object type

This is a toggle command in the Model View toolbar. When this command is selected all diagrams and elements in the Model View tree are grouped by type.

- Within each node, elements are grouped by element type (tasks, gateways, etc.).
- Element Type header icons include a folder indicator ()

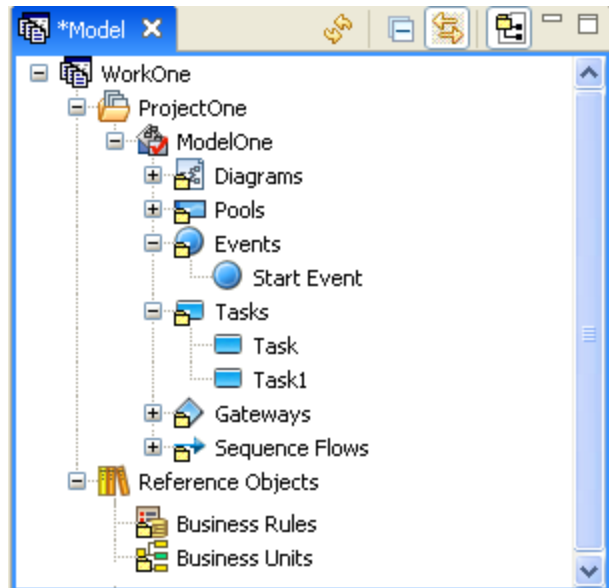

**NOTE:** Element type groupings can also be turned off under [Preferences](#).

- Under each node or header, items are sorted alphabetically, unless there is a sequence associated with an element (lanes, for example).

## Palette view

In addition to the palette that appears in the Diagram View when you open ER/Studio BA, you can also have the option to open the Palette View, which then replaces the Palette in the Diagram View. This view contains the same information, but this palette can be moved and docked different places inside and outside of the application. You can display the palette view if hidden, and modify how and where the palette is displayed.

### Displaying the Palette view

To display this Palette View, do the following:

Click **Window > Show View > Palette** on the main menu and a tabbed Palette View opens. Since only one palette can be visible at a time, this replaces the palette located in the Diagram View.

**NOTE:** Once you close this Palette View, the palette in the Diagram View reappears.

### Modifying the palette

You can modify the Palette View. When you right-click the Palette tab, a shortcut menu opens displaying the following commands:

Command	Description
Detached	Click this command to detach the view from the application main frame and position it anywhere within or outside the application window. This state of detachment is called floating. This is a toggle command and the Detached command is checked once it is selected.
Move	You move a single view or an entire tab group. When you select this command, the select view or tab group is outlined with a gray box. Move the gray box to a selected location and click once. The view or tab group is placed in the new location.
Size	You can the resize the top, bottom, left or right side on a view. Click Size and then select one of the four available sides. The selected side is replaced by a dark blue line. Place the cursor on this line and the cursor changes to resize. Hold down the button and move the side to the desired location.
Close	This command closes the selected view. You can also click  located in the tab to close the view.



## Error Logging view

All generated error messages for ER/Studio BA, appear in the log. Various [icons](#) are used to identify the type of error. When using the Error Logging view, the [toolbar](#) allows you to manipulate the log. The following information is displayed for each error in the Error Logging View:

Column	Description
Message	Displays information on what caused the error to occur.
Plug-in	Displays the plug-in where the error occurred.
Date	Displays the date and time the error message was generated.

The following message types are displayed: Fatal, Error, Warning, Information, Debug, and Trace.

### Displaying the Error Logging view

To display the Logging view when hidden, do the following:

- 1 On the Window menu, select Show View.
- 2 Select Error Logging from the pull-right menu.

### Modifying the Error Logging view



You can modify the Error Logging view. When you right-click the Error Logging tab, a shortcut menu opens displaying the following commands:

Command	Description
Detached	Click this command to detach the view from the application's frame and position it anywhere within or outside the application window. This state of detachment is called floating. This is a toggle command and the Detached command is checked once it is selected.
Restore	Restores a maximized window to its original size within the application.
Move	You move a single view or an entire tab group. When you select this command, the select view or tab group is outlined with a gray box. Move the gray box to a selected location and click once. The view or tab group is placed in the new location.
Size	You can the resize the top, bottom, left or right side on a view. Click Size and then select one of the four available sides. The selected side is replaced by a dark blue line. Place the cursor on this line and the cursor changes to resize. Hold down the button and move the side to the desired location.
Minimize	This command hides the view and only the icon and tab representing the view are displayed in the application window. Click once in the tab to restore the view to its original size and location.
Maximize	The view is expanded to fill the entire application window.
Close	This command closes the selected view. You can also click  located in the tab to close the view.











## Event type icons

The table below displays the icons used to specify the state of the event type.

Toolbar Icon	Element
	Error markers are often used to indicate the source location of syntax or compilation errors.
	Warning markers indicate the source location of, for example, compilation warnings.
	Information markers indicate the source location of information only tasks.

## Error Logging toolbar

The table below details the icons and their function on the Error Logging toolbar.

Toolbar Icon	Element	Description
	Copy	A displayed log entry can be copied to the clipboard.
	Clear Log Viewer	Clears all error messages from the Error Logging view.
	Delete Log	Deletes all logged events from the view and the log file no longer exists. A message dialog opens asking for confirmation of the action.
	Open Log	Launches a text viewer showing the contents of the log file.
	Reload Log	After a log is cleared it can be restored. <b>Note:</b> If a file has been deleted, it cannot be restored.
	<a href="#">Export Log</a>	When you select this icon, a Save As dialog opens. The displayed Error Log file can be saved in a directory of your choice and is saved as a text file with a .log file extension.
	<a href="#">Import Log</a>	You can import an existing .log file.
	<a href="#">Importing an Error Log</a>	Opens a dialog listing details about the event messages.

## Using the Error Logging view

You can [import](#) or export an error log, and [filter](#) an error log. If you need additional information on a specific error you can also open the [Events Details](#) dialog.

### Importing an error log

- 1 [Open](#) the Error Logging view.
- 2 Click the Import icon  on the toolbar and the Open dialog box opens.  
**NOTE:** The default location is your current project file and the default file extension is .log.
- 3 Select the log file you want to import and click OK. The imported file appears in the Error Logging view.

### Exporting an error log

- 1 [Open](#) the Error Logging view.
- 2 Click the Export icon  on the toolbar and the Save As dialog opens.
- 3 Select the folder where you want the log exported to and name the file. The default location is your current project file and the default file extension is .log.
- 4 Click OK and the file is exported.

### Filtering an error log

You can use this command to select which event types to filter in the view display. This filter controls what is displayed in the error view, not the error log.

You can specify several options in the Filter Commands dialog box. The table below describes these options:

Element	Explanation
Information	Select this option to display Information event types in the Error Logging View.
Warning	Select this option to display Warning event types in the Error Logging View.
Error	Select this option to display Error event types in the Error Logging View.
Limit Visible Events	Enter the number of events you want to appear in the Error Logging View.
Show Events Logging During:	All Sessions: Displays all events logged for all sessions. Most Recent Session: Displays only events logged during your most recent session.

### Opening the Log Filters dialog box

- 1 In the Error Logging view click  in the toolbar and a shortcut menu opens.
- 2 Select Filters and the Log Filters dialog opens.

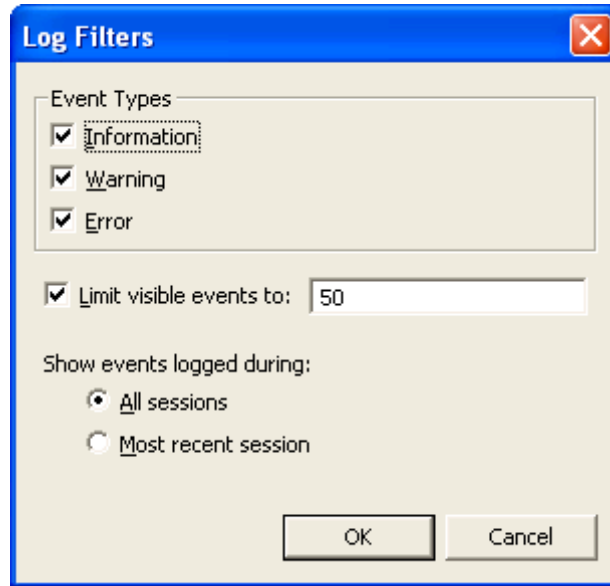

- 3 Select the Event Types to be displayed: Information, Warning and/or Error.
- 4 Enter the number of events to be displayed in the Limit Visible Events text box.
- 5 Select which logging session you want displayed.
- 6 Click OK and the changes made appear in the Error Logging view.

Using the Event Details dialog box

You can view details of each error message logged in the Error Logging view.

- 1 Right-click an error in the Error Logging view.
- 2 Select Event Details to open the Event Details dialog.

The following information is displayed:

Event Detail	Description
Date	Displays the date and time the error message was generated.
Severity	Displays the symbol and type of error.
Message	Displays information on the cause of the error generated.
Exception Stack Trace	Displays the exceptions generated.
Session Data	Displays the build identification number for Eclipse.

## Help view

When you open the Help View it opens as a pane located in the right-hand section of the application. This view dynamically displays the related topics of a selected view. You can [use](#) this view to search for the information you need to use the application. The Help View is divided into two sections:

Section	Description
About	This top portion of the view displays the name of the view selected. For example if Model View is selected the title would be About Model View.
Dynamic Help	Displays all topics related to the view selected.

**NOTE:** You can also gain access to online [Help](#) by selecting Help > Help Contents from the main menu. The online help opens in a separate window

### Displaying the Help view

To display the Help view when hidden, do the following:

- 1 On the Window menu, select Show View.
- 2 Select Help from the pull-right menu.

### Modifying the Help view

You can modify the Help view. When you right-click the Help tab, a shortcut menu opens displaying the following commands:







Command	Description
Detached	Click this command to detach the view from the application's frame and position it anywhere within or outside the application window. This state of detachment is called floating. This is a toggle command and the Detached command is checked once it is selected.
Restore	Restores a maximized window to its original size within the application.
Move	You move a single view or an entire tab group. When you select this command, the select view or tab group is outlined with a gray box. Move the gray box to a selected location and click once. The view or tab group is placed in the new location.
Size	You can the resize the top, bottom, left or right side on a view. Click Size and then select one of the four available sides. The selected side is replaced by a dark blue line. Place the cursor on this line and the cursor changes to resize. Hold down the button and move the side to the desired location.
Minimize	This command hides the view and only the icon and tab representing the view are displayed in the application window. Click once in the tab to restore the view to its original size and location.
Maximize	The view is expanded to fill the entire application window.
Close	This command closes the selected view. You can also click  located in the tab to close the view.

## Using the Help view

When you click a topic in the Dynamic Help list, that topic opens in the view. The [Help View Toolbar](#) that appears at the top of the view helps you navigate the available information. You also have additional [command icons](#) that appear at the bottom of the view.









### Help view toolbar

When you open the Help View, the following commands appear in the toolbar:

Toolbar Icon	Element	Description
	Show in External Window	<p>Opens the currently displayed Help topic in an external window. When you open this window, two additional icons appear in the toolbar:</p> <ul style="list-style-type: none"> <li>• Show in Table of Contents: Click  and the name of the topic displayed in the window is highlighted in the table of contents.</li> <li>• Print: Click  and the Print dialog opens allowing you to print the currently displayed topic.</li> </ul>
	Show in All Topics	Displays the table of contents with the current Help topic highlighted.
	Bookmark Document	Click this icon to bookmark the current Help topic. The bookmarked topics are displayed when you click the Bookmarks icon in the <a href="#">Go To</a> section.
	Back	Click this icon to return to the view that was displayed immediately prior to the current display.
	Forward	This command displays the view that was displayed immediately after the current display. This command is similar to the Forward button in an HTML browser.

## Help view Go To icons

In addition to the Help View toolbar, additional icons are displayed at the bottom of the Help View. The table below displays and explains each icon.

Toolbar Icon	Element	Description
	All Topics/ Related Topics	This is a toggle command. When you select All Topics, a table of contents opens displaying all topics. The command now available is Related Topics. This switches the view back to the Dynamic Help view.
	Search	Opens the Search dialog where you can enter a search expression to search the online Help topics. When the Results of the search are displayed, each displays icons allowing you to open a link in the Help window (  ) and/or bookmark (  ) the Result.  Two additional icons appear in the Search dialog: <ul style="list-style-type: none"> <li>• Show Result Categories: This is a toggle icon  that hides or displays the main help category headings.</li> <li>• Show Result Descriptions: This is a toggle icon  that hides or displays the description containing the search expression.</li> </ul>
	Related Topics	Displays all the topics related to the currently displayed topic in the Help view.
	Bookmarks	Displays a list of all the Help topics that you have bookmarked. You can click on any listed item to display that topic.

## Overview window

The Overview window is a scalable window displaying any diagram in its entirety. You can use this window to quickly and easily navigate the diagram. If the current diagram is larger than its Diagram View, the Overview window also displays a scalable box denoting the Diagram View's field of view. By moving or changing the size of this scalable box, you can change the Diagram View, effectively panning through the current diagram, or zooming in and out of it. For large diagrams, the Overview window is a much more powerful navigation tool than using a combination of ER/Studio BA scroll bars and zoom features.

### Displaying the Overview view

To display the Overview view when hidden, do the following:

- 1 On the Window menu, select Show View.
- 2 Select Overview from the pull-right menu.

## Modifying the Overview view

You can modify the Overview view. When you right-click the Overview tab, a shortcut menu opens displaying the following commands:

Command	Description
Detached	Click this command to detach the view from the application's frame and position it anywhere within or outside the application window. This state of detachment is called floating. This is a toggle command and the Detached command is checked once it is selected.
Restore	Restores a maximized window to its original size within the application.
Move	You move a single view or an entire tab group. When you select this command, the select view or tab group is outlined with a gray box. Move the gray box to a selected location and click once. The view or tab group is placed in the new location.
Size	You can the resize the top, bottom, left or right side on a view. Click Size and then select one of the four available sides. The selected side is replaced by a dark blue line. Place the cursor on this line and the cursor changes to resize. Hold down the button and move the side to the desired location.
Minimize	This command hides the view and only the icon and tab representing the view are displayed in the application window. Click once in the tab to restore the view to its original size and location.
Maximize	The view is expanded to fill the entire application window.
Close	This command closes the selected view. You can also click  located in the tab to close the view.

## Search results

- 1 Open this view by selecting Window > Show View > Search Results. This displays the name and type of elements found in a search.

**NOTE:** This view opens automatically after a [Search](#), if it isn't already open.

- 2 Double-click an element in the list. If it is not on a diagram, a Message dialog opens tell you that the select element was not found on any diagrams.

If the element you double-click is on a diagram, the Diagram Usage dialog opens showing the diagram(s) the element appears on.

- 3 Select the diagram from the list and click OK to open the desired diagram.





# ER/Studio Business Architect tools – Importing and exporting

ER/Studio BA provides import and export functions that extend the usability of the application. The import/export functions available in ER/Studio BA are listed below:

Function	Description
<a href="#">Diagrams</a>	You can export Business Process diagrams, Conceptual diagrams and Impact Analysis diagrams in three different formats: rtf, pdf, and jpg.
<a href="#">Grid Editor</a>	You can export the Grid Editor in the four different formats: csv, html, pdf, and rtf.
Workspaces	<p><a href="#">Export</a>: You can export a workspace in a compressed format (file extension .exz). This function allows you to (1) archive your workspace and/or (2) send to another user where it can be reimported.</p> <p><a href="#">Workspace</a>: This function allows you to import the exported compressed file from another user, from the archives, etc.</p>
<a href="#">CSV Files</a>	<p>Certain data residing in Comma Separated Value files can be imported into ER/Studio BA.</p> <p>You can also export data to a CSV file using the <a href="#">Grid Editor</a>.</p>
Conceptual Models	<p>You can <a href="#">import</a> or <a href="#">update</a> ER/Studio DA logical models into ER/Studio BA's conceptual models.</p> <p><a href="#">Note</a>:Conceptual Models can also be <a href="#">exported</a> to ER/Studio DA as a logical model.</p>
External Data Objects	<p><a href="#">Export</a>: External Data Objects can be exported to ER/Studio DA as a logical and physical model.</p> <p>You can <a href="#">Import</a> or <a href="#">Update</a> ER/Studio DA models into the application as external data objects.</p>
<a href="#">Visio Import</a>	You can import Visio diagrams into Business Process or Conceptual models. When you import a Visio model, you create a new model and associated diagrams.

## CSV file import

You can import large amounts of data in the Comma Separated Value file into ER/Studio BA. You can import the following:

- Reference Objects
- Business Elements
- Business Rules
- Business Units
- Stewards
- Business Entities
- Subject Areas
- Tasks

By using pre-existing templates, you can input data into a comma separated value file and then import it into the application. A template exists for each object available in ...:\Program Files\IDERA\ERStudio Business Architect X.X\samples\CSV\Templates. You can open these templates in Microsoft Excel or any text editor to enter data.

### Importing a CSV File

- 1 On the main menu, select File > Import > Comma Separated Values (CSV)... and the Object Type and File Location dialog opens.
- 2 Select the object type you want imported. Your options are Business Elements, Business Entities, Business Rules, Business Units, Stewards, Subject Areas, and Tasks.
- 3 Browse to the file location where the CSV file to be imported is located and select your file.
- 4 You can import CSV files with or without headers. If the file you are importing has headers, select the "First line in file is header" option.

**CAUTION:** If you do not select this option and your file has headers, your first row will be imported as data. For example if your headers were Name, Data Type, Description, and Notes, when the file is imported, your first row of data would be the Name, Data, Type, Description and Notes. This may cause errors because the import values will be invalid.

- 5 Click Next.
- 6 If you are importing [Tasks](#), the Pool and Diagram Selection dialog opens. If you are importing [Subject Areas or Entities](#), the Model and Diagram Selection dialog opens. This allows you to select a diagram on which elements appear.
- 7 If there are elements that exist with the same name the Possible Duplicate Elements dialog opens. You can choose to create a new element with a unique name or update the existing element. When updating existing elements the following will occur: (1) Elements in the project having corresponding objects in the import are updated with new information; and (2) Objects in the import without corresponding elements in the project are added to the project as new elements.

- 8 If there are problems with the import, a Problems in File dialog opens. A table lists any errors, warnings, or information, as well as the line number of the problem.
  - Click Launch Editor to open the application associated with the CSV extension, where you can view and correct any problems.
  - Once you have corrected the problem click Revalidate.
- 9 If the import is successful, an Import Summary dialog opens displaying all the records that have been imported.
- 10 Click Finish and a CSV Import Complete notification dialog opens telling you how many elements were created in ER/Studio BA.
- 11 Once you close the notification dialog, the imported elements are placed under the appropriate node in the Model View tree, and on the associated diagram.
  - If you are importing reference objects, once you close the notification dialog, the imported elements are placed under the appropriate Reference Object node in the Model View tree.
  - If you are importing Tasks, they are placed in a model and on a diagram, if you selected one. You will be prompted where to place them on the next page of the Import Wizard.
- 12 You can then drag these elements on to an existing diagram. When you double-click on an element, the Property View for that element opens displaying the imported data.

### Importing Tasks

When you import a task, you must place the imported tasks in either an existing pool or create a new one.

- 1 After you have completed the [Object Type and File Location](#) dialog, click Next and the Pool and Diagram Selection dialog opens.
- 2 If you chose to use an existing pool, click Next and the Lane and Diagram Selection dialog opens where you must select a lane in a model to contain the created elements.
  - Select a Lane from the hierarchy.
  - Select "Add elements to a diagram" if you want the newly imported element added to the diagram.
  - Select an existing diagram and click Next.
  - If elements are found with the same name, the [Possible Duplicate Elements](#) dialog opens.
- 3 If you chose to create a new pool you must enter the name of the new pool.
  - Click Next and the Model and Diagram Selection dialog opens. You must select the model where the elements should be created.
  - Click Add elements to a diagram if you want the imported tasks to appear in a diagram. You have two options: (1) You can create a new diagram (the default name of the new diagram is the new pool name); or (2) You can use an existing diagram from the list box.

- 4 Click Next and the Import Summary dialog opens displaying the name and description of the imported elements.
- 5 Click Finish. If you selected the option to add elements to a diagram, that diagram opens with the imported tasks. If you did not select this option, the imported elements are added to the Model View tree and a dialog opens telling you how many elements were imported.

### Importing Business Entities and Subject Areas

Business Entities and Subject Areas are imported using a slightly different wizard. It is similar to importing tasks but you are not required to place the entities or subject areas in a pool. Also, the imported elements are automatically added to a diagram.

- 1 On the main menu, select File > Import > Comma Separated Values (CSV)... and the CSV Import Wizard opens.
- 2 Select the object type. In this case select either Subject Areas or Business Entities.
- 3 Browse to the file location where the CSV file to be imported is located and select your file.
- 4 You can import CSV files with or without headers. If the file you are importing has headers, select the "First line in file is header" option.

**CAUTION:** If you do not select this option and your file has headers, your first row will be imported as data. For example if your headers were Name, Data Type, Description, and Notes, when the file is imported, your first row of data would be the Name, Data, Type, Description and Notes. This may cause errors because the import values will be invalid.

- 5 In the Model and Diagram Selection dialog, select the model or diagram to contain the imported elements.
- 6 Click Add elements to a diagram if you want the imported element to appear in a diagram. You have two options: (1) You can create and name a new diagram; or (2) You can use an existing diagram from the list box.
- 7 If there are elements that exist with the same name the Possible Duplicate Elements dialog opens. You can choose to create a new element with a unique name or update the existing element. When updating existing elements the following will occur: (1) Elements in the project having corresponding objects in the import are updated with new information; and (2) Objects in the import without corresponding elements in the project are added to the project as new elements.
- 8 If there are problems with the import, a Problems in File dialog opens. A table lists any errors, warnings, or information, as well as the line number of the problem.
  - Click Launch Editor to open the application associated with the CSV extension, where you can view and correct any problems.
  - Once you have corrected the problem click Revalidate.
- 9 Click Next and the Import Summary dialog opens displaying the name and description of the imported elements which will be created in the model.

- 10 Click Finish. If you selected the option to add elements to a diagram, that diagram opens with the imported tasks. If you did not select this option, the imported elements are added to the Model View tree and a dialog opens telling you how many elements were imported.

## Conceptual models

Conceptual Modeling allows you to create high-level designs of core business concepts to gain acceptance and requirements from the business. These high-level Conceptual models can be forward engineered to create detailed Logical Data Models in ER/Studio DA. In addition to process-specific information, related business information can also be linked to data objects such as business rules, business elements, business units, and stewards. You can import and update from ER/Studio DA as well as Export to ER/Studio DA with customized mappings.

Related Topics:

- [Conceptual Model Import from ER/Studio DA](#)
- [Conceptual Model Update from ER/Studio DA](#)
- [Conceptual Model Export to ER/Studio DA](#)

### Conceptual model import from ER/Studio Data Architect

You can import ER/Studio DA logical model elements and domains into an ER/Studio BA conceptual model. The import uses pre-defined [mapping](#). A mapping table is also included for [Bound Business Elements](#). The following rules apply to the elements you are importing from ER/Studio DA:

- When you select a main model/submodel, all the entities inside that submodel are moved to the Selected Entities tree. A subject area and diagram are created for each submodel.
- If you deselect the diagram that was created, the subject area and all the entity metadata stays in the Selected Entities tree.
- When importing ER/Studio DA diagrams with super/subtype relationships, the supertype entities will not be expanded automatically. However, an expander indicator () will appear in the parent entity indicating the presence of children.
  - If the Show expansion control [preference](#) is set, expanders are shown for all entities after an import. If the preference is not set, the expander is displayed only when there are children.
- You do not have to [import all the attributes](#) for a given entity. You can select one or more attributes you want imported from the list of all attributes in an entity.
- If you deselect a subject area that was created, all its nested subjects with their corresponding diagrams are removed from the Selected Entities tree.

- If you import a model having relationships with verb phrases, the verb phrases are imported and displayed the diagram by default
- If the business name of a relationship is shown in an ER/Studio DA model, they are displayed on import, even if the "show name on creation" preference is not set for relationships.
- There are two kinds of Entity nodes: EntityData in the Main Model, and EntityDisplay in the Submodel.
  - If you select an Entity under the Main Model (which is an EntityData) then only the entity is moved to the Selected Entities tree with its nested entities. No subject areas and diagram are created.
  - If you select an Entity under a Submodel (which is an EntityDisplay), a diagram and subject area are created in addition to the Entities.
- If you select a Supertype node, both the parent and children of this supernode are selected as well.

The following rules apply to the created Business Elements when you import domains from ER/Studio DA:



- ER/Studio DA domains are created as Business Elements.
- The enforce name property of the created business elements is always cleared. Therefore, the "override name" option is never set on Business Attributes created through the import process.
- The enforce data type, description, and notes properties are pulled from the "allow override" options on the ER domains themselves. Business attributes are no longer checked to see if they actually override the properties.
- If the domains allow the properties to be overridden, the "enforce" options are cleared accordingly on the business element. The "override" options are never enabled on the business attributes, even though the properties may differ from those of the business element.
- If the domains do not allow the properties to be overridden, the "enforce" options are set accordingly on the business element. The "override" options are enabled on all business attributes. The properties should match those of the business element because of ER/Studio DA behavior.

#### Importing an ER/Studio DA Model to a Conceptual Model

- 1 In the Model View tree right-click the project or conceptual model where you want the imported ER/Studio DA model to be placed.
- 2 Select Import > From ER/Studio Data Architect > Create New Conceptual Objects....
- 3 In the Source Name and Location dialog, select the ER/Studio DA diagram you want to import. You can browse to the location of the diagram. Under Model options, the Model Name is the default name of the ER/Studio DA model you are importing.
- 4 In the tree, select where you want the model to be placed and click Next.

- 5 In the Object Selection dialog you can specify the objects you want included in the model. There are two tabs: Entities and Domains. Under the Entities tab, the Available Entities tree shows the entity hierarchy for the ER/Studio DA Logical model, including Super and Sub-types.

**NOTE:** All the physical models in the ER/Studio DA file are ignored. Also, ER/Studio DA views are not imported because the Conceptual model does not have a corresponding type.

- From the list of Available Entities, select the entities you want to import and click . You can select multiple objects by holding down the CTRL key and clicking individual objects. You can also import the entire list by clicking . All the selected entities are moved to the Selected Object tree.
  - If you want to import only selected attributes within an entity, expand the entity and select the attributes you want to import and click . You can select multiple attributes by holding down the Ctrl key and clicking individual attributes. The entity and only the attributes you selected are moved to the Selected Object tree.
  - Nested Submodels are imported as nested Subject Areas. A diagram with the same name as the Subject Area is created and a map is created between the diagram and the Subject Area after the import.
  - The Model name that appears under Model Options on the first panel of the wizard appears in the Selected Entities panel.
- 6 After you have made your selections on the Entities tab, click the Domains tab. You can select the type of element you want the domain imported as. Your three options are: Business Elements, Domains, and Business Elements Referencing Domains.

**NOTE:** You can set a default [preference](#) for your import type.

- 7 All domains in the ER/Studio DA model are listed. See [Importing ER/Studio Data Architect Domains as ER/Studio BA Domains](#) for the rules that apply when importing ER/Studio DA domains.

**NOTE:** If you only want to see bound domains, select that option "Only show domains bound to selected entities" located below the Available domains list box. In ER/Studio DA you can bind a domain to an entity attribute, so this option filters out domains that are not bound to entities. If no entities are selected for inclusion in the import, this option is not available.

- 8 Click Finish and the imported model with all its associated diagrams, subject areas, and entities is placed in the Model View tree.

**CAUTION:** For diagrams, relationship bend points and connection points are not imported and/or updated. They will be auto-routed using the default routing algorithms).

## Conceptual model update from ER/Studio Data Architect

If you are working on an ER model, you can frequently update your associated EA conceptual model, if that ER/Studio BA model was initially created by importing the ER model. The ER model changes can include entity name changes, adding and removing new attributes, adding and removing relationships, binding and unbinding existing domains, etc. Because updates are based on an object's unique identity rather than its name, you have ability to re-import just the changes, or the entire ER model, and the existing ER/Studio BA Conceptual Model is updated. All existing relationships are maintained, and renamed elements are updated properly.

**NOTE:** You can import several different ER models into a single Conceptual Model, and update this model when required.

**CAUTION:** Only the elements that were originally created by importing the ER model are updated. Any elements that are created in ER/Studio BA are not updated with information imported from the ER model. For example, you have created an entity named "EntityOne" in ER/Studio BA. If you import an ER model with an entity with the same name containing attributes and descriptions, those attributes and descriptions are not added to the existing ER/Studio BA entity.

The following rules are implemented when updating a Conceptual Model from ER/Studio DA:

Element	Rules
Subject Areas	<p>If you import several ER models into the same Conceptual Model, a unique identifier is stored with each submodel in a hidden attribute.</p> <p>You can rename submodels, move entities between other submodels, and subject area mappings are updated.</p>
Entities	<p>Along with existing properties, a unique identifier is stored in a hidden attribute on the entity which includes the ER model name. When an ER update occurs, each ER entity unique identifier is matched with ER/Studio BA's entities to determine the match. This allows any property of the ER/Studio BA's entity to be change (including name), without breaking the 'link' to the existing ER entity.</p>
Attributes	<p>As new attributes are added, removed, renamed, or reordered in the ER entity, the information is properly updated in the ER/Studio BA model, because each attribute has a unique identifier stored in a hidden attribute.</p>
Entity Relationships	<p>Each relationship that is imported will include a unique identifier in a hidden attribute to identify it and match it with the corresponding relationship in the ER model.</p> <p>When updating elements with relationships:</p> <ul style="list-style-type: none"> <li>• You only need to pick one node connected in a relationship. The import discovers the other end of the relationship, and leaves the relationship connected.</li> <li>• If Entities with the same name already exist in the Conceptual Model, a new unique name is created.</li> </ul>





Element	Rules
Bound Domain Relationships	<p>You have option to import domains as business elements or domains, or both.</p> <p>When updating entities:</p> <ul style="list-style-type: none"> <li>• If a bound domain is renamed, the import detects this situation and renames the associated business element or domain, depending on how the ER domains are imported.</li> <li>• If the override properties of a domain are changed, the import changes the same override properties in ER/Studio BA.</li> <li>• When an ER model is imported that has a domain with the same name as an existing business element/domain, a new business element/domain is created.</li> <li>• When an existing entity's attribute is bound to a new domain, and you import only the entity, the new binding is detected and includes the new domain as well. (This assumes you have not excluded it during the import.)</li> <li>• If an existing entity's attribute is disassociated with a domain the binding is broken in ER/Studio BA.</li> </ul>

#### Updating from ER/Studio DA

- 1 Right-click a Conceptual Model in the Model View tree and select Import > From ER/Studio Data Architect > Update Existing Conceptual Objects.
- 2 In the Update Conceptual Objects > Source Name and Location dialog select the location of the ER/Studio DA diagram that contains the source of the conceptual objects you want updated. You can browse to the location of the .dm1 file.
- 3 In the workspace tree, select the target model you want updated.
- 4 You can select the "Delete objects in model that aren't contained in source file." If you enable this option, any objects in the target model that no longer exists in the ER model are deleted. If this option is not selected, (it is not selected by default), none of the objects in the target model are deleted.

**NOTE:** This option does not work with domains. Since Business Elements/Domains are shared objects that can be bound to objects completely outside the scope of the update, they can not be deleted.

- 5 Click Next and the Object Selection dialog opens. From the list of Available entities, select the objects you want to export and click . You can select multiple objects by holding down the Ctrl key and clicking individual objects. You can also import the entire list by clicking . All the selected entities are moved to the Selected Entities tree.
- 6 After you have made your selections on the Entities tab, click the Domains tab and all domains in the ER/Studio DA model are listed.

**NOTE:** For updates, domains are preselected based on what bound entities are picked.

**CAUTION:** If you do not include all the elements that are connected with relationships, the existing relationships will be severed because the “connected” element was not included in the update.

7 Click Finish and the following happens:

- The selected objects are compared with objects in the selected target model.
- Existing target objects that match a corresponding source object will have all of the properties updated with those properties in the source objects.
- If an element in an ER model is renamed, and the conceptual model is updated, the old entity is replaced with a new entity of the same name.
- Source objects that do not match any existing target objects will be created in the target model/diagrams.
- If a partial model is updated, any relationships that existed are lost if the other end of the relationship was not selected in the update wizard.
- Relationships are matched by how their nodes are matched. Once a match is determined, all relationship properties, including its name, are updated.
- If you have selected the “Delete objects in model that aren’t contained in source file” option on the previous page of the wizard, existing target objects will get deleted if they do not match any object in the ER model.

**CAUTION:** For diagrams, relationship bend points and connection points are not imported and/or updated. They will be auto-routed using the default routing algorithms.

## Conceptual model export to ER/Studio Data Architect

You can export conceptual models to ER/Studio DA where the elements in the conceptual diagram map to the logical diagram in ER/Studio DA.

You can choose to export all or part of the elements on a model by right-clicking on a Conceptual Model node () in the Model View and selecting Export > Model to ER/Studio Data Architect.... This command is also available on the File menu.

If you want to export all or part of the elements present on a specific Conceptual Model diagram, right-click on the desired diagram node () and select Export Diagram to ER/Studio Data Architect. This command is also available on the File menu.

The export uses pre-defined [mapping](#). A mapping table is also included for [Bound Business Elements](#). Click [here](#) for instructions on using the export wizard.

**NOTE:** Models are exported to a format which can be opened in ER/Studio Data Architect 7.0 and above.

The following rules apply to the export of Subject Areas:

- Subject areas are exported as sub-models

- All nested Subject Areas will be exported according to Subject Area containment, creating nested submodels.
- Business Entities mapped to subject area will be exported as entities under that submodel
- Business Entities contained in the subject area (on a diagram) will be exported as entities under that submodel
- Nested Subject Areas will be exported based on mappings.
- Mapped diagrams will export Business Entities in the diagram not contained in Subject Areas.
- Mapped diagrams will not export the diagram's Subject Areas and its contents



The following rules apply to the export of Entities and Attributes

- Nested Business Entities will be exported as logical entities connected by a super-type/sub-type relationships.
- Individually selected Business Entities will be exported as logical entity without exporting its parent subject area
- If you have Business Entities with Name Collisions, (Business Entity name from one model is the same as the name of a Business Entity from another model) one of the Business Entities' names will be renamed by appending with a string like "\_1".
- Business Entities mapped to the Subject Area will be exported, including the nested Business Entities. Both the parent and child Business Entities will be selected together.

Exporting the Conceptual Model to ER/Studio DA

- 1 In the Model View tree, right-click on either the conceptual model or diagram you want to export to ER/Studio DA and select Export to ER/Studio Data Architect....
- 2 In the Export to ER/Studio Data Architect dialog, name your exported file in the File Name text box.

**NOTE:** The file extension of ".dm1" is automatically added.

- 3 Click Browse in the Directory text box to find the directory where you want to store you exported file. The default directory is ...My Documents\ERStudioBusinessArchitect.
- 4 From the list of Available elements, select the objects you want to export and click . You can select multiple objects by holding down the Ctrl key and clicking individual objects. You can also import the entire list by clicking . A Business Entity element maps as a logical subnode under the main model. The Subject Area element maps as a top level node in the Logical hierarchy
- 5 The objects to be exported appear in the Selected Elements list box as ER/Studio DA objects.

- 6 Click OK and the export dialog closes. If you set the appropriate [preferences](#), the Open generated model in ER/Studio Data Architect... option is selected in the dialog. The exported model is then opened automatically in ER/Studio DA.

### Mappings between ER/Studio Business Architect and ER/Studio Data Architect

Exporting to ER/Studio DA is based on a pre-defined mapping to create the appropriate ER constructs from the Conceptual Model. The table below outlines the Entity mappings. There is also a section that covers the [Attribute Optionality](#) mapping and [Attribute Datatypes](#) mapping.

ER/Studio BA Object	ER/Studio DA Object
Subject Area	Submodel
Diagram	Submodel Diagram
Subject Area Name	Sub-Model Name
Nested Subject Area	Nested Sub-Model
Business Entity	Entity (Data)
Business Entity Name	Entity name and Table name
Business Entity Description	Entity Definition
Business Attribute	Attribute inside the entity
Business Attribute Name	Attribute Name and Default Column Name
<a href="#">Business Elements</a>	Domain
Binding between Business Element and Business Attribute	Bounded Domain
Relationships	<a href="#">Relationships</a>
Interaction	No mapped in ER/Studio DA
Inheritance (Business Entities)	Supertype/Subtype
Inheritance (Subject Area)	Nested Submodels

### Bound Business Elements

If a Business Attribute is bound to a Business Element, the attribute is mapped to the Domain. The Attribute definition is mapped to that from the domain.

ER/Studio BA	ER/Studio DA
Business Element	Domain
Business Element Name	Domain Name, Attribute Name, Column Name
Business Element Datatype	Domain Datatype
Business Element Description	Domain Definition. Definition of bound attributes

## Relationships

In ER/Studio DA, relationship directions will be drawn in same direction as in ER/Studio BA. Relationships between business entities are exported as relationships between logical entities. The following are rules for each relationship type:

ER/Studio BA	ER/Studio DA
Relationship Name	Business Name
Relationship Description	Relationship Definition
Verb phrase	Verb Phrase (for Many to One relationships, Inverse Verb Phrase)
Inverse verb phrase	Inverse Verb Phrase (for Many to One relationships, Verb Phrase)
Type: Generic	Non-specific
Type: Many to Many	Non-specific
Type: One to Many, Mandatory	Non-identifying with the end point at the child. Existence = Mandatory, Cardinality = One to Zero or More
Type: One to Many, Optional	Non-identifying with the end point at the child. Existence = Optional, Cardinality = Zero or One to Zero or More
Type: Many to One, Mandatory	Non-identifying with the begin point at the child.(reversed parent-child relationship and verb, inverse verb phrases). Existence = Mandatory, Cardinality = One to Zero or More
Type: Many to One, Optional	Non-identifying with the begin point at the child.(reversed parent-child relationship and verb, inverse verb phrases). Existence = Optional, Cardinality = Zero or One to Zero or More

**NOTE:** Optional/Mandatory relationship settings are carried over to ER/Studio DA. If no optional/mandatory setting exists, you have the option to define what the default treatment is (i.e., export a non-specified optionality as either optional or mandatory). The default is that a non-specified relationship will be set to mandatory.

## Attribute Optionality and Datatypes

The first table lists the Attribute Optionality mapping.

ER/Studio BA	ER/Studio DA
Mandatory	Allow Nulls = No
Optional	Allow Nulls = Yes
Unspecified	Allow Nulls = Yes

This table displays the Attribute Datatypes mappings.

ER/Studio BA	ER/Studio DA
Binary	BINARY(10)
Boolean	BIT
BLOB/Image	IMAGE / LONG

ER/Studio BA	ER/Studio DA
Char	CHAR(10)
CLOB/Large Text	LONG
Decimal	DECIMAL(8, 2)
Date	DATE
Integer	INTEGER
None	CHAR(10)
Timestamp	TIMESTAMP/DATE
Varchar	TEXT
XML	XML(ER 7.1 and above) or VARCHAR(10) (ER 7.0)

## External data objects

You can use an External Data Object (EDO) in a diagram for [reference](#) or for [data flow diagramming](#). You can then link to External Data Objects with a specific business process or task. There are two different types of External Data Objects: Logical and Physical. The Logical types are entities and attributes. The Physical types are tables and views.

Related Topics:

- [External Data Object Import from ER/Studio DA](#)
- [External Data Object Update from ER/Studio DA Files](#)
- [External Data Object Export to ER/Studio DA](#)

### External data object import from ER/Studio Data Architect

You can [import](#) or [update](#) External Data Objects from ER/Studio DA files using a wizard. This import parses the DM1 file to extract the appropriate data objects. These extracted objects are then loaded into the application's storage.

- 1 From the main menu, select File > Import > From ER/Studio Data Architect > External Data Objects > Create New....



OR

In the Model View, right-click the External Data Objects node and select Import > From ER/Studio Data Architect > Create New External Data Objects....

- 2 In the Import External Data Objects dialog specify the source of the external data objects by selecting an ER/Studio DA diagram. You can find the file you want to import by clicking Browse. The Data Source Name that is created is based on the imported file name. However, you can change this name if desired.

- 3 Click Next and the Model Selection panel opens. Specify which models you want imported into the data source. The model selection is based on the file you selected in the previous panel. To narrow down your selection, you can expand the models available and select specific models you want to import.
- 4 When you click Next, the Object Selection panel opens. The objects that appear are based on the selections you made in the previous panel. You have three tabs containing imported objects

Tab	Description
Entities	Displays a list of all available entities based on the selection made in the Model Selection panel. Expand the nodes to gain access to the individual entities.
Tables	Displays a list of all available tables based on the selection made in the Model Selection panel. Expand the nodes to gain access to the individual tables.
Views	Displays a list of all available Views based on the selection made in the Model Selection panel. Expand the nodes to gain access to the individual views.

- 5 Select the object(s) you want to import and click . You can select multiple objects by holding down the Ctrl key and clicking individual objects. You can also import the entire list by clicking .
- 6 Click Finish and a dialog opens telling you that the import was successful. Click Details... for information on what was imported. You can print or save this information.
- 7 Click OK and the imported objects appear in the Reference Objects node under the Data Source name that you created in the first panel of the wizard.

## External data object update from ER/Studio Data Architect files

You can use the Update External Data Objects option to update an existing External Data Object data source that you have already imported. All existing objects that match an object you have selected will be updated. All objects that you have selected but are not in the existing data source will be brought in as new.

When updating existing elements the following occurs:

- Elements in the data source having corresponding objects in the import are updated with new information.

- Objects in the import without corresponding elements in the data source are added to the data source as new elements.

**NOTE:** All links and diagram references to updated External Data Objects are still valid.

- 1 Choose File > Import > From ER/Studio Data Architect > External Data Objects > Update Existing... from the main menu.

OR

Right-click the External Data Objects node in the Model View tree and select Import > From ER/Studio Data Architect > Update Existing External Data Objects....

OR

Right-click an existing data source node () in the Model View tree and select Import > From ER/Studio Data Architect > Update Existing External Data Objects....

- 2 In the Location text box, specify the source of the external data objects.
- 3 Select the data source containing the existing elements to be updated.
- 4 You can select the "Delete objects in model that aren't contained in source file." If you enable this option, any objects in the target model that do not match an object that you select in the source model for update is deleted. If this option is not selected, (it is not selected by default), none of the objects in the target model are deleted.
- 5 Click Next and select the models to be updated in the Model Selection dialog.
- 6 Click Next and the Object Selection dialog opens. Select the entities, tables, and/or views from the Available Objects window, that you want included in the Selected list box.
- 7 Click Finish and a dialog opens telling you that the import was successful. Click Details... for information on what was imported. You can print or save this information.
- 8 Click OK and the updated objects appear in the External Data Objects node or the Data Source that you were updating.



## External data object export to ER/Studio Data Architect



You can export External Data Objects to ER/Studio DA where all entity elements map to a logical model and all table elements map to a physical model in ER/Studio DA. Only entities and tables are exported. The export uses pre-defined [mapping](#).

**NOTE:** Models are exported to a format which can be opened in ER/Studio DA 7.0 and above.

- 1 Right-click an External Data Objects node in the Model View tree, or a datasource node.
- 2 Select Export to ER/Studio Data Architect and the Export to ER/Studio Data Architect dialog opens.

OR

Select the External Data Objects node and click File > Export > To ER/Studio Data Architect... .

- 3 In the Export to ER/Studio Data Architect dialog, the default name for the exported file is the data source name with the file extension of ".dm1". You can change this name or leave the default setting.
- 4 The default directory is ER/Studio BA's default workspace directory: "...MyDocuments\ERStudioBusinessArchitect". You can browse to a new location as well and make a new directory.
- 5 From the list of Available Elements, select the elements you want to export and click . You can select multiple elements by holding down the Ctrl key and clicking individual items. You can also import the entire list by clicking . All the selected elements are moved to the Selected Elements tree.
- 6 Click OK and the export dialog closes. If you set the appropriate [preferences](#), the "Open generated model in ER/Studio DA..." option is selected in the dialog. The exported model is then opened automatically in ER/Studio DA.

## External data object to ER/Studio Data Architect mappings

Exporting to ER/Studio DA is based on a pre-defined mapping to create the appropriate ER constructs from the External Data Objects. The first table below shows the Entity Attribute Datatype mappings. The second table shows the Table Column Datatypes.

Entity Attribute Datatypes	ER/Studio DA Object
Binary (W)	BINARY(W)
Boolean	BIT
Char(W)	CHAR(W)
Date	DATE
Decimal	DECIMAL(W, S)
Float	FLOAT

Entity Attribute Datatypes	ER/Studio DA Object
Integer	INTEGER
Long Binary	IMAGE / LONG BINARY
Money (W, S)	MONEY(W, S)
Timestamp	TIMESTAMP / DATE
Varchar (W)	VARCHAR (W)
XML	XML (ER 7.1 and above) or VARCHAR (W) (ER 7.0)

Table Column Datatypes	ER/Studio DA Object
Binary(W)	BIT VARYING (W)
Boolean	BIT
Char(W)	CHAR(W)
Date	DATE
Decimal	DECIMAL (W, S)
Float	FLOAT
Integer	INTEGER
Long Binary	VARCHAR (100)
Money(W, S)	DECIMAL(W, S)
Timestamp	TIMESTAMP
Varchar (W)	VARCHAR (W)
XML	VARCHAR (4000)

## Visio import

You can import Microsoft® Visio diagrams into both the Conceptual and Business Process models. When you import a Visio model, the wizard walks you through the creation of a model and associated diagrams. Most Visio models were created using the basic drawing shapes or flowcharting objects. With the ER/Studio BA Visio import, you can convert these drawing shapes into meaningful Business Process Modeling Notations or data objects (for example a circle becomes a start event).

When you use the import feature:

- A [mapping](#) table lists the Visio objects and the corresponding ER/Studio BA objects. You can change these mappings.
- A diagram is created for each page in the Visio model.

- The following font properties used in the model are imported as well: name, size, bold, italic, underline, strikethrough and color.

**NOTE:** Microsoft® Office Visio® 2003 or 2007 must be installed on your computer to use this feature.

### Using the Import Feature

- 1 From the main menu select File > Import > Microsoft Visio Model... to open the Microsoft Visio Import Wizard.

OR

In the Model View tree, right-click the workspace or a project and click Import > Microsoft Visio Model.

- 2 In the Microsoft Visio Import Wizard dialog, browse to the folder where your existing Visio models are stored and select the model you want to import. The two file type options are .vsd (drawing) and .vdx (xml drawing).
- 3 Click Open to accept your selection and close the Browse dialog.

**CAUTION:** Make sure that the model you are importing is closed in Visio.

**NOTE:** When importing Visio models, the connections in Visio must show red anchors (indicating that it is anchored) on both the source and target elements in order for ER/Studio BA to create the connection.

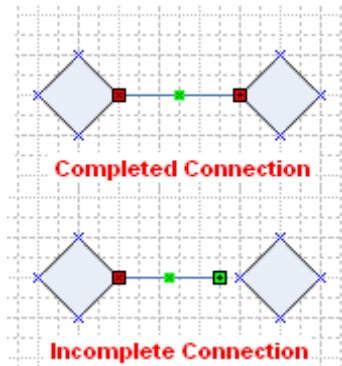

- 4 Select either Business Process or Conceptual for the model type you want to import.
- 5 Click Next to advance to the Model and Diagram Details dialog where you can specify the details of the model and diagrams to be created during the import process.
- 6 In the Model Name text box, enter the model name for the imported information or leave default name, which is the name of the Visio model you are importing.
- 7 You can create the model under the existing workspace, project, or model. In the hierarchy, click on the node where you want the model placed.

**NOTE:** The model that appears in the hierarchy depends on the model type you selected in the first panel of the wizard.

- 8 The Diagram Options section lists the Visio page name and the corresponding ER/Studio BA diagram name that will be created for each page of the Visio model. The page name that appears is based on the page name in Visio. You can change the default diagram name by pressing F2, which puts you in the edit mode.
- 9 When you click Next the Mapping Visio Objects to ER/Studio BA Objects opens. The table lists the Visio object types, the page name where it is located, and their corresponding ER/Studio BA object types.
- 10 When doing an import, you can use a [previously saved custom map](#), use the default mappings, or map individual objects, including each individual element in the Visio Model. This is called [Instance-Level Mappings](#).
- 11 Once you have completed your mapping decisions, click Finish and the Importing Visio Objects dialog opens telling you that the import was successful.
 

**NOTE:** If any warnings were generated they are listed in the dialog. You can print and/or save this dialog.
- 12 Click OK and all the imported diagrams open in the Diagram View area.
- 13 In the Model View tree, the imported diagrams are listed with all associated elements listed as subnodes.
 

**NOTE:** When importing Visio models into ER/Studio BA, if you use default Visio shape sizes, the ER/Studio BA objects are created using default ER/Studio BA sizes. If an element is resized in Visio, you can set [preference](#) to ensure that the resizing is carried over to ER/Studio BA.

### Creating Custom Mappings

You can create and save user-defined mappings for a Visio object type in the Mapping dialog.

- 1 Select the Visio Object Type you want to map.
- 2 Click the corresponding ER/Studio BA Object Type and a drop-down list box opens. You can also press F2. This list box contains all supported Modeling elements (including embedded and independent sub-processes), Reference Objects, External Data Objects, Drawing Shapes, as well as the settings "Default" and "None". Select the item you want to map to.
- 3 Repeat for each object you want to map.

**NOTE:** If you want to restore the original mappings, click the Restore Default Objects Mapping

icon ()

- 4 To save your settings, click  to open the Save Mappings dialog.
- 5 Enter the name you want to use for the saved mappings. It will be saved as an XML file.

## Using Custom Mappings











- 1 On the Mapping Visio Objects to ER/Studio BA Objects panel of the wizard, click the Use Custom Object Mappings option in the Custom Mapping Options group box. The Mapping File Location and Browse options are made available.
- 2 Click Browse to go to the location where you saved your Custom Mapping files.  
**NOTE:** You can set a [preference](#) for your default custom mapping file location.
- 3 Click Open and the Custom Mapping file is loaded and will be used when importing the Visio model.

**NOTE:** Click Reload Custom Mapping Options () to restore the original state of your custom mappings file. This reload eliminates any mapping changes you made unless you saved the file.

## Instance-Level Mappings

You can map each individual object in the Visio model.

- 1 Click  next to a Visio Object Type to display the individual objects. In the following example there are three Decisions listed under the Decision Object Type.

Visio Object Type and Object Names	Page Name	EA/Studio Object Type
 Database		Data Store
 Decision		Gateway (Data-Based without Marker)
Application Approved?	Customer Lo...	Gateway (Data-Based without Marker)
Autoapprove?	Lender Loan...	Gateway (Data-Based without Marker)
Loan Approved?	Lender Loan...	Gateway (Data-Based without Marker)
 Dynamic connector		Association/Sequence Flow
 Dynamic connector.12		Association
 Event		Start Event
 Function		Task
 Functional band		Lane
 Horizontal holder		Pool
 Magnetic tape		Data Feed
 Terminator		End Event

- 2 Click the ER/Studio BA Object Type column of the specific Visio Object type you want to map and a drop-down list opens displaying all the available ER/Studio BA object types.

Visio Object Type and Object Names	Page Name	EA/Studio Object Type
⊕ Database		Data Store
⊖ Decision		Gateway (Data-Based without Marker)
Application Approved?	Customer Lo...	Gateway (Data-Based without Marker)
Autoapprove?	Lender Loan...	Gateway (Data-Based without Marker)
Loan Approved?	Lender Loan...	Gateway (Event-Based)
⊕ Dynamic connector		Gateway (Inclusive)
⊕ Dynamic connector.12		Gateway (Parallel)
⊕ Event		Data Feed
⊕ Function		Data Object
⊕ Functional band		Data Store
⊕ Horizontal holder		Embedded Sub-Process
⊕ Magnetic tape		End Event
⊕ Terminator		Flat File
		Independent Sub-Process
		Intermediate Event
		Line
		Message Flow
		Off-Page Connector

- 3 Select the object type you want to use and the selected object now appears in the column. This mapping is used in the import process.

**CAUTION:** The Instance-level mappings are not saved as part of the custom mapping file. You will get an “Unable to Save Instance-Level Mappings” warning dialog when you click Save. You have the option to “Always save current object type mappings without prompting”. You can also set a prompt-level [preference](#) for this dialog.

## Mapping Visio objects to ER/Studio Business Architect objects

There are eight mapping tables showing all the object types that are currently imported from Visio to ER/Studio BA:

- [Basic Flowchart Shapes](#)
- [Audit Diagram Shapes](#)
- [EPC Diagram Shapes](#)
- [Basic Shapes](#)
- [Block Diagram Shapes](#)
- [Cross-Functional Flowchart Shapes Horizontal](#)
- [Cross-Functional Flowchart Shapes Vertical](#)

## Basic Flowchart Shapes

Visio Object Type	ER/Studio BA Object Type
Process	Task
Decision	Gateway
Document	Data Object
Predefined Process	Task
Manual Operation	Task
Preparation	Task
Parallel Mode	Task
Loop Limit	Task with Standard Loop Type
Terminator	End Event
On-Page Reference	Off-Page Connector
Off-Page Reference	Off-Page Connector
Auto-height box	Annotation
Dynamic Connector	Sequence Flow Association Interaction (depending on type of source/target element and the model type)
Line-curve connector	Sequence Flow Association Interaction (depending on type of source/target element and the model type)
Control Transfer	Sequence Flow Interaction (depending on model type)
Annotation	Annotation
Stored Data	Data Store
Paper Tape	Data Feed
Data	Data Store
Direct Data	Data Store
Manual Input	Data Store
Sequential Data	Data Feed
Display	Report

## Audit Diagram Shapes

Visio Object Type	ER/Studio BA Object Type
Tagged Process	Task
Decision	Gateway

Visio Object Type	ER/Studio BA Object Type
Manual Operation	Task
Terminator	End Event
On-page Reference	Off-Page Connector
Off-Page Reference	Off-Page Connector
Divided Process	Pool
Multi Process/Doc	Pool
Lined/Shaded Process	Pool
Check 1 (audit)	Gateway
Compare 1	Gateway
Divided Event	Task
Title Block	Annotation
Note Block	Annotation
Dynamic Connector	Sequence Flow Association Interaction (depending on type of source/target element and the model type)
Line-curve connector	Sequence Flow Association Interaction (depending on type of source/target element and the model type)
Database	Data Store
Data Transmission	Data Feed
Diskette 1	Data Feed
Diskette 2	Data Feed
Disk Storage	Data Store
Lined Document	Flat File
Magnetic Tape	Data Feed
Manual File	Flat File
Manual Input	Flat File
Multi-document	Flat File
Tagged Document	Flat File
Display	Report



## EPC Diagram Shapes

Visio Object Type	ER/Studio BA Object Type
Event	Start Event
Function	Task
Process Path	Pool
XOR	Data-Based Gateway (with Marker)
OR	Inclusive Gateway
AND	Parallel Gateway
Dynamic Connector	Sequence Flow Association Interaction (depending on type of source/target element and the model type)
Organizational Unit	Business Unit
Enterprise Area	Subject Area

## Basic Shapes

Visio Object Type	ER/Studio BA Object Type
Square	Task/Business Entity (depending on model type)
Circle	Start Event
Ellipse	Start Event
Rectangle	Task/Business Entity (depending on model type)
Shadowed Box	Task/Business Entity (depending on model type)
3-D Box	Task/Business Entity (depending on model type)
Rounded Rectangle	Task/Business Entity (depending on model type)
Rounded Square	Task/Business Entity (depending on model type)
45 degree single	Line/Relationship (depending on model type)
60 degree single	Line/Relationship (depending on model type)
Fancy arrow	Line/Relationship (depending on model type)
45 degree double	Line/Relationship (depending on model type)
60 degree double	Line/Relationship (depending on model type)
45 degree tail	Line/Relationship (depending on model type)
60 degree tail	Line/Relationship (depending on model type)
Flexi-arrow 1	Line/Relationship (depending on model type)
Flexi-arrow 2	Line/Relationship (depending on model type)
Flexi-arrow 3	Line/Relationship (depending on model type)
Double flexi-arrow	Line/Relationship (depending on model type)

Visio Object Type	ER/Studio BA Object Type
Dynamic Connector	Sequence Flow Association Interaction (depending on type of source/target element and the model type)
Line-curve connector	Sequence Flow Association Interaction (depending on type of source/target element and the model type)

### Block Diagram Shapes

Visio Object Type	ER/Studio BA Object Type
Box	Task
Mid-Arrow	Sequence Flow/Relationship (depending on model type)

### Cross-Functional Flowchart Shapes Horizontal

Visio Object Type	ER/Studio BA Object Type
Functional Band	Horizontal Pool

### Cross-Functional Flowchart Shapes Vertical

Visio Object Type	ER/Studio BA Object Type
Functional Band	Vertical Pool

# Property views

This appendix describes the fields in the Property Views for Workspaces, Projects, Models, Diagrams, and Business Process Modeling Elements and Conceptual Modeling Elements.

## Workspaces

A workspace is a unit of storage used for any collection of data modeling projects in the ER/Studio BA. The application lets you only open and work with one workspace at a time, but you can collect any number of projects in a single workspace. You can edit the properties of a workspace.

### Opening the Workspace Properties

- 1 Right-click the workspace node name in the Model View tree.
- 2 Select Properties and the Workspace Properties dialog for the selected workspace opens.

The table below describes the Property View fields available for Workspaces:

Property View	Description
General	
Name	Label that appears for a workspace both in the Model View tree and in the diagram.
Location	Displays the path for the workspace.
ER/Studio BA Version	Displays the version of ER/Studio BA.
Description	
	<p>A text box where you can enter information describing or defining the project. Right-click text to open a shortcut menu. You can cut, copy, paste, and delete selected text within the Description text box. You can paste plain text from external applications.</p> <p>You can undo any action and you can select all text by pressing Ctrl+A.</p> <p>The following formatting options are available for the text: Bold, Italics, Underscore, and Strikethrough. You can also change the font color as well as the background color.</p>

Property View	Description
Notes	<p>A text box where you can annotate the element with additional information. Right-click text to open a shortcut menu. You can cut, copy, paste, and delete selected text within the Notes text box. You can paste plain text from external applications.</p> <p>You can undo any action and you can select all text by pressing CTRL+A.</p> <p>The following formatting options are available for the text: Bold, Italics, Underscore, and Strikethrough. You can also change the font color as well as the background color</p>

## Projects

A Project is a collection of items including models, model elements, documents, business rules, etc. You can nest projects where a project is a parent of another project. A project does not have to contain a model. You can edit the properties of a project.



### Opening the Project Properties





- 1 Right-click the project node name in the Model View tree.
- 2 Select Properties and the Project Properties dialog for the selected project opens.

The table below describes the Properties fields available for Projects:

Property View	Description
General	
Name	Label that appears for a project both in the Model View tree and in the diagram.
Location	Displays the path and file name for the selected project.
ER/Studio BA Version	Displays the ER/Studio BA version.

Property View	Description
Description	
	<p>A text box where you can enter information describing or defining the project. Right-click text to open a shortcut menu. You can cut, copy, paste, and delete selected text within the Description text box. You can paste plain text from external applications.</p> <p>You can undo any action and you can select all text by pressing CTRL+A.</p> <p>The following formatting options are available for the text: Bold, Italics, Underscore, and Strikethrough. You can also change the font color as well as the background color.</p>
Notes	
	<p>A text box where you can annotate the element with additional information. Right-click text to open a shortcut menu. You can cut, copy, paste, and delete selected text within the Notes text box. You can paste plain text from external applications.</p> <p>You can undo any action and you can select all text by pressing CTRL+A.</p> <p>The following formatting options are available for the text: Bold, Italics, Underscore, and Strikethrough. You can also change the font color as well as the background color.</p>
Links	
Add Link	Opens the <a href="#">Create Link</a> wizard. This wizard allows you to create conceptual or usage links between elements.
Edit Link	Opens the property view for the selected link.
Delete Link	Deletes the selected link (either the link or the link target).
Show Selected Links on Active Diagram	Once you have created a link in the Diagram View, click this icon to display the links for the selected object in the diagram.
Expand All	Expands all the nodes in the tree.
Collapse All	Collapses all the nodes in the tree.
Refresh Links	Updates all the nodes in the Link Report.

Property View	Description
Usage (CRUD)	
Usage	<p>The header displays the name of the linked element and the status of the filter (on or off).</p> <p>Receivers: Displays a list of the elements with usages (receivers). You can select multiple receivers in this list and delete all the receivers that are selected.</p> <p>Usage: Displays the usage setting (C, R, U, D). You can change the Usage attributes in this column and this change is reflected in the diagram. For example, you can change a C (Create) type to a U (Update) type.</p> <p>Usage Description: Displays the information entered in the Description text field for the target object of the usage. For example, if a usage was drawn between a task and a Data Store object, the description of the Data Store object is displayed.</p> <p>If there are no links or all the links have been filtered out, you are given the information that "No usages have been defined for this element" in the Receivers column.</p>
<a href="#">Add Usage</a>	Opens the Create Usage wizard where you can create a new usage.
<a href="#">Edit Usage</a>	<p>When you select a Receiver in the table, the edit option becomes available. Click this to open the Usage edit tab where you can edit the name of the usage. The default name is "Usage". You can also change the usage settings (Create, Read, Update, and Delete).</p> 
Delete	<p>When you select a Receiver in the table, the delete option becomes available. This action removes the selected receiver from the usage.</p> 
Show Selected Usages	<p>When you select a Receiver in the table, the Show Selected Usages option () becomes available. Click this icon to display the usage for the selected receiver in the diagram, including the usage settings.</p>
Filter Receiver Types	Opens the Usage Report Filter dialog where you can select the types of objects you want included in the Usage Report.
<a href="#">Export Usage Report</a>	You can export the Usage (CRUD) reports in the following formats: CSV, HTML, PDF, and RTF
<a href="#">Print</a>	Opens the Print dialog where you can select a printer, set preferences, select a page range and number of copies and then print.
Refresh Usage	Updates all the nodes in the Usage Report.

Property View	Description
Impact Analysis	
Filter Designation	<p>Indicates whether a <a href="#">Filter</a> has been set for the Impact Analysis Report.</p> <p>Two icons are displayed to the left of the Filter Designation indicator:</p> <p> Click  to display the impact analysis information in a tree format.</p> <p> Click  to display the impact analysis information in a table format.</p>
<a href="#">Create Impact Analysis Diagram</a>	Once you create a link you can create a diagram that is a graphical representation of that link.
<a href="#">Filter</a>	Opens the Impact Analysis Filter dialog
Export	You can export and save the Impact Analysis report in the following file formats: CSV, HTML, PDF, and RTF.
Print	Opens the Print dialog where you can select a printer, set preferences, select a page range and number of copies and then print.
Expand All	Expands all the nodes in the tree.
Collapse All	Collapses all the nodes in the tree.
Refresh	Updates all the nodes in the Impact Analysis Report.

## Models

A model is a specific collection of elements/objects related to the Business Process Modeling Notation. The Model contains Business Process Diagrams which are graphical representations of all the elements of the process.

### Opening Model Properties



- 1 Right-click the model node name in the Model View tree.
- 2 Select Properties and the Model Properties dialog for the selected diagram opens.





The table below describes the Properties fields available for Models:

Property View	Description
General	
Name	Label that appears for a model both in the Model View tree and in the diagram.
Location	Displays the path and file name for the selected model.
ER/Studio BA Version	Displays the ER/Studio BA version.

Property View	Description
Model Type	Displays the type of model, either Business Process or Conceptual.
Validate against BPMN Specification  Note: This property is available only for Business Process models.	The validation checks compliance to the Business Process Modeling Notation specifications. The option available depends on the model type. For example, if BPMN validation is enabled and you draw a message flow from one start event to another, you get a dialog stating that this is an invalid relationship. If validation is off, it is drawn without notification.
Description	
	<p>A text box where you can enter information describing or defining the project. Right-click text to open a shortcut menu. You can cut, copy, paste, and delete selected text within the Description text box. You can paste plain text from external applications.</p> <p>You can undo any action and you can select all text by pressing Ctrl+A.</p> <p>The following formatting options are available for the text: Bold, Italics, Underscore, and Strikethrough. You can also change the font color as well as the background color.</p>
Notes	
	<p>A text box where you can annotate the element with additional information. Right-click text to open a shortcut menu. You can cut, copy, paste, and delete selected text within the Notes text box. You can paste plain text from external applications.</p> <p>You can undo any action and you can select all text by pressing Ctrl+A.</p> <p>The following formatting options are available for the text: Bold, Italics, Underscore, and Strikethrough. You can also change the font color as well as the background color.</p>
Links	
Add Link	Opens the <a href="#">Create Link</a> wizard. This wizard allows you to create conceptual or usage links between elements.
Edit Link	Opens the property view for the selected link.
Delete Link	Deletes the selected link (either the link or the link target).
Show Selected Links on Active Diagram	Once you have created a link in the Diagram View, click this icon to display the links for the selected object in the diagram.
Expand All	Expands all the nodes in the tree.
Collapse All	Collapses all the nodes in the tree.
Refresh Links	Updates all the nodes in the Link Report.



Property View	Description
Usage (CRUD)	
Usage	<p>The header displays the name of the linked element and the status of the filter (on or off).</p> <p><b>Receivers:</b> Displays a list of the elements with usages (receivers). You can select multiple receivers in this list and delete all the receivers that are selected.</p> <p><b>Usage:</b> Displays the usage setting (C, R, U, D). You can change the Usage attributes in this column and this change is reflected in the diagram. For example, you can change a C (Create) type to a U (Update) type.</p> <p><b>Usage Description:</b> Displays the information entered in the Description text field for the target object of the usage. For example, if a usage was drawn between a task and a Data Store object, the description of the Data Store object is displayed.</p> <p>If there are no links or all the links have been filtered out, you are given the information that "No usages have been defined for this element" in the Receivers column.</p>
<a href="#">Add Usage</a>	Opens the Create Usage wizard where you can create a new usage.
<a href="#">Edit Usage</a>	<p>When you select a Receiver in the table, the edit option becomes available. Click this to open the Usage edit tab where you can edit the name of the usage. The default name is "Usage". You can also change the usage settings (Create, Read, Update, and Delete).</p> 
Delete	<p>When you select a Receiver in the table, the delete option becomes available. This action removes the selected receiver from the usage.</p> 
Show Selected Usages	<p>When you select a Receiver in the table, the Show Selected Usages option () becomes available. Click this icon to display the usage for the selected receiver in the diagram, including the usage settings.</p>
Filter Receiver Types	Opens the Usage Report Filter dialog where you can select the types of objects you want included in the Usage Report.
<a href="#">Export Usage Report</a>	You can export the Usage (CRUD) reports in the following formats: CSV, HTML, PDF, and RTF.
<a href="#">Print</a>	Opens the Print dialog where you can select a printer, set preferences, select a page range and number of copies and then print.
Refresh Usage	Updates all the nodes in the Usage Report.

Property View	Description
Impact Analysis	
Filter Designation	<p>Indicates whether a <a href="#">Filter</a> has been set for the Impact Analysis Report.</p> <p>Two icons are displayed to the left of the Filter Designation indicator:</p> <p> Click  to display the impact analysis information in a tree format. This is the default display and includes the following main nodes: workspace hierarchy, Diagram Usage, Heritage, Links, Bindings, and Mappings.</p> <p> Click  to display the impact analysis information in a table format. This display includes the Impact Topic, Element Type, Name, Target Element Type, and Target Element Name</p> <p>Items in the tree will be exported and/or printed in the format you select with the exception of CSV, which cannot be displayed in the tree format.</p>
<a href="#">Create Impact Analysis Diagram</a>	Once you create a link you can create a diagram that is a graphical representation of that link.
<a href="#">Filter</a>	Opens the Impact Analysis Filter dialog
Export	You can export and save the Impact Analysis report in the following file formats: CSV, HTML, PDF, and RTF.
Print	Opens the Print dialog where you can select a printer, set preferences, select a page range and number of copies and then print.
Expand All	Expands all the nodes in the tree. This option is disabled if the Table format is selected.
Collapse All	Collapses all the nodes in the tree. This option is disabled if the Table format is selected.
Refresh	Updates all the nodes in the Impact Analysis Report.

## Diagrams

A Business Process Diagram (BPD) uses a flowcharting technique which is tailored for creating graphical models of business process operations. A Business Process Model is a network of graphical elements based on the Business Process Modeling Notation, which track the flow of activities and their order of performance.

### Opening Diagram Properties

You have different properties available for the [Business Process](#) diagram and the [Conceptual Model](#) diagram.

- Right-click the diagram node name in the Model View tree and select Properties.

**NOTE:** At the time you create a diagram, a [Pool](#) and a [Lane](#) are automatically created.

The table below describes the Properties fields available for Business Process Diagrams:.



Property View	Description
General	
Name	Label that appears for an element both in the Model View tree and in the diagram. You can edit this label.
Location	Displays the path where the diagram file, with the file extension of .edsb, is stored.
ER/Studio BA Version	Displays the Version number of ER/Studio BA.
Diagram Version	Displays the Version of the diagram
Author	This text field contains the name of the author of the Diagram.
Creation Date	This displays the date on which the Diagram was created (for this Version).
Last Modification Date	This defines the date on which the Diagram was last modified (for this Version).
Language	This text field contains the name of the language in which text is written. The default is English.
Expression Language	A Language may be provided so that the syntax of expressions used in the Diagram can be understood.
Query Language	A Language may be provided so that the syntax of queries used in the Diagram can be understood.
Description	
	<p>A text box where you can enter information describing or defining the project. Right-click text to open a shortcut menu. You can cut, copy, paste, and delete selected text within the Description text box. You can paste plain text from external applications.</p> <p>You can undo any action and you can select all text by pressing CTRL+A.</p> <p>The following formatting options are available for the text: Bold, Italics, Underscore, and Strikethrough. You can also change the font color as well as the background color.</p>



Property View	Description
Notes	
	<p>A text box where you can annotate the element with additional information. Right-click text to open a shortcut menu. You can cut, copy, paste, and delete selected text within the Notes text box. You can paste plain text from external applications.</p> <p>You can undo any action and you can select all text by pressing CTRL+A.</p> <p>The following formatting options are available for the text: Bold, Italics, Underscore, and Strikethrough. You can also change the font color as well as the background color</p>
Pools	
Name	Displays the name of all the pools in the diagram.
Boundary Visible	Indicates whether or not the pool is visible on the diagram.
Edit Pools	Click  to open the <a href="#">Edit Pools</a> Property View.





### Edit Pools Property View

When you click the Edit Pool icon, an additional Property View opens.

Property View	Description
General	
Name	Label that appears for a pool both in the Model View tree and in the diagram.
Categories	You can add one or more defined Categories that can be used for purposes such as reporting and analysis
Participant	You must define the Participant for a Pool. The Participant can be either a Role or an Entity. This defines the role that a particular Entity or Role the Pool will play in a Diagram that includes collaboration.
<a href="#">Process</a>	When you click  an additional property view opens displaying the Process properties for the selected diagram.
Boundary visible	This attribute defines if the rectangular boundary for the Pool is visible. Only one Pool in the Diagram may have the attribute set to False.
Linked steward or business unit	Click the drop-down arrow to display a list of available stewards and business units that can be linked to a pool.

Property View	Description
Description	
	<p>A text box where you can enter information describing or defining the project. Right-click text to open a shortcut menu. You can cut, copy, paste, and delete selected text within the Description text box. You can paste plain text from external applications.</p> <p>You can undo any action and you can select all text by pressing Ctrl+A.</p> <p>The following formatting options are available for the text: Bold, Italics, Underscore, and Strikethrough. You can also change the font color as well as the background color.</p>
Notes	
	<p>A text box where you can annotate the element with additional information. Right-click text to open a shortcut menu. You can cut, copy, paste, and delete selected text within the Notes text box. You can paste plain text from external applications.</p> <p>You can undo any action and you can select all text by pressing CTRL+A.</p> <p>The following formatting options are available for the text: Bold, Italics, Underscore, and Strikethrough. You can also change the font color as well as the background color.</p>
Lanes	
Name	<p>Displays the name and description of the lane(s) within the selected pool. You have the following functions available:</p> <p>Add: Adds another lane to the pool. If you opened the Property View from the Model View, the new lane appears in the Model View tree. If you opened the Property View from the presentation element, the new lane appears both in the Model View tree and in the Diagram View.</p> <p>Edit: Opens a Property View for the selected lane where you can make changes to the properties for that lane. Notice that the <a href="#">Appearance</a> tab is not available on this page.</p> <p>Delete: Delete the selected lane from this Property View.</p>
Create Lane	Click  to create a new lane.
Edit Lane	Select a lane in the list box and click Edit (  ). The Lane property view for the selected lane opens.
Delete Lane	Delete a selected lane by clicking  . The lane is immediately deleted without a warning.

Property View	Description
Move Lane Up	Move the selected lane up in the grid.
Move Lane Down	Move the selected lane down in the grid.
Links	
Add Link	Opens the <a href="#">Create Link</a> wizard. This wizard allows you to create conceptual or usage links between elements.
Edit Link	Opens the property view for the selected link.
Delete Link	Deletes the selected link (either the link or the link target).
Show Selected Links on Active Diagram	Once you have created a link in the Diagram View, click this icon to display the links for the selected object in the diagram.
Expand All	Expands all the nodes in the tree.
Collapse All	Collapses all the nodes in the tree.
Refresh Links	Updates all the nodes in the Link Report.
Usage (CRUD)	
Usage	<p>The header displays the name of the linked element and the status of the filter (on or off).</p> <p><b>Receivers:</b> Displays a list of the elements with usages (receivers). You can select multiple receivers in this list and delete all the receivers that are selected.</p> <p><b>Usage:</b> Displays the usage setting (C, R, U, D). You can change the Usage attributes in this column and this change is reflected in the diagram. For example, you can change a C (Create) type to a U (Update) type.</p> <p><b>Usage Description:</b> Displays the information entered in the Description text field for the target object of the usage. For example, if a usage was drawn between a task and a Data Store object, the description of the Data Store object is displayed.</p> <p>If there are no links or all the links have been filtered out, you are given the information that "No usages have been defined for this element" in the Receivers column.</p>
<a href="#">Add Usage</a>	Opens the Create Usage wizard where you can create a new usage.
<a href="#">Edit Usage</a>	When you select a Receiver in the table, the edit option becomes available. Click this to open the Usage edit tab where you can edit the name of the usage. The default name is "Usage". You can also change the usage settings (Create, Read, Update, and Delete). 
Delete	When you select a Receiver in the table, the delete option becomes available. This action removes the selected receiver from the usage. 
Show Selected Usages	When you select a Receiver in the table, the Show Selected Usages option (  ) becomes available. Click this icon to display the usage for the selected receiver in the diagram, including the usage settings.
Filter Receiver Types	Opens the Usage Report Filter dialog where you can select the types of objects you want included in the Usage Report.

Property View	Description
<a href="#">Export Usage Report</a>	You can export the Usage (CRUD) reports in the following formats: CSV, HTML, PDF, and RTF
<a href="#">Print</a>	Opens the Print dialog where you can select a printer, set preferences, select a page range and number of copies and then print.
Refresh Usage	Updates all the nodes in the Usage Report.
Impact Analysis	
Filter Designation	<p>Indicates whether a <a href="#">Filter</a> has been set for the Impact Analysis Report.</p> <p>Two icons are displayed to the left of the Filter Designation indicator:</p> <p> Click  to display the impact analysis information in a tree format.</p> <p> Click  to display the impact analysis information in a table format.</p>
<a href="#">Create Impact Analysis Diagram</a>	Once you create a link you can create a diagram that is a graphical representation of that link.
<a href="#">Filter</a>	Opens the Impact Analysis Filter dialog
Export	You can export and save the Impact Analysis report in the following file formats: CSV, HTML, PDF, and RTF.
Print	Opens the Print dialog where you can select a printer, set preferences, select a page range and number of copies and then print.
Expand All	Expands all the nodes in the tree.
Collapse All	Collapses all the nodes in the tree.
Refresh	Updates all the nodes in the Impact Analysis Report.

The table below describes the Properties fields available for Conceptual Model Diagrams:.

Property View	Description
General	
Name	Label that appears for an element both in the Model View tree and in the diagram. You can edit this label.
Location	Displays the path where the diagram file, with the file extension of .edsb, is stored.
ER/Studio BA Version	Displays the version number of ER/Studio BA

Property View	Description
Description	
	<p>A text box where you can enter information describing or defining the project. Right-click text to open a shortcut menu. You can cut, copy, paste, and delete selected text within the Description text box. You can paste plain text from external applications.</p> <p>You can undo any action and you can select all text by pressing CTRL+A.</p> <p>The following formatting options are available for the text: Bold, Italics, Underscore, and Strikethrough. You can also change the font color as well as the background color.</p>
Notes	
	<p>A text box where you can annotate the element with additional information. Right-click text to open a shortcut menu. You can cut, copy, paste, and delete selected text within the Notes text box. You can paste plain text from external applications.</p> <p>You can undo any action and you can select all text by pressing CTRL+A.</p> <p>The following formatting options are available for the text: Bold, Italics, Underscore, and Strikethrough. You can also change the font color as well as the background color.</p>

## Business process modeling diagram elements

This section describes the Property View fields for the Business Process Modeling diagram modeling elements. There are eight major divisions describing the modeling elements:

- [Events](#)
- [Activities](#)
- [Gateways](#)
- [Connecting Objects](#)
- [Swimlanes](#)
- [Artifacts](#)
- [Reference Objects](#)
- [Drawing Shapes](#)



## Opening Properties for Diagram Elements

Right-click the diagram element node name in the Model View tree and select Properties.

OR

Double-click the element in the Diagram View and the Property View dialog for the selected element opens.

**NOTE:** When you open a Property View from an element in the Diagram View, an [Appearance](#) Tab is available. However, when you open a Property View for an element in the Model View tree, the Appearance tab does not appear.

## Events



There are three event types used in the diagrams: [Start Event](#); [Intermediate Event](#); and [End Event](#).







### Start Event

The table below describes the Property View fields available for a Start Event:

Property View	Description
General	
Name	Label that appears for an element both in the Model View tree and in the diagram. You can edit this label.
Categories	You can add one or more defined Categories that can be used for purposes such as reporting and analysis.
Trigger Type	Displays the type of trigger attached to this event: message, time, rule, or link.
Description	
	<p>A text box where you can enter information describing or defining the project. Right-click text to open a shortcut menu. You can cut, copy, paste, and delete selected text within the Description text box. You can paste plain text from external applications.</p> <p>You can undo any action and you can select all text by pressing Ctrl+A.</p> <p>The following formatting options are available for the text: Bold, Italics, Underscore, and Strikethrough. You can also change the font color as well as the background color.</p>

Property View	Description
<b>Notes</b>	
	<p>A text box where you can annotate the element with additional information. Right-click text to open a shortcut menu. You can cut, copy, paste, and delete selected text within the Notes text box. You can paste plain text from external applications.</p> <p>You can undo any action and you can select all text by pressing CTRL+A.</p> <p>The following formatting options are available for the text: Bold, Italics, Underscore, and Strikethrough. You can also change the font color as well as the background color</p>
<a href="#">Triggers</a>	
Type	When you select a trigger icon, the type you selected appear in this column.
Name	This column displays the name. Each time you add a trigger, the name is appended by a number, for example, trigger1, trigger2, etc.
Properties	<p>The type of trigger selected determines the information displayed in the description text box. Each trigger type is listed below with the information it displays:</p> <p>Link: Link identification and process reference.</p> <p>Message: Implementation type, From, and To.</p> <p>Rule: Rule Name.</p> <p>Timer: Time cycle information.</p>
Trigger Icons	All the trigger icons are located at the bottom of the Property View. Only the triggers available for this element are available. Click the trigger icon you want to set and it appears in the grid.
<a href="#">Edit Triggers</a>	Click this option (  ) to open the Trigger event Property View.
Delete Trigger	Deletes the trigger type from the selected event.
<b>Assignments</b>	
Name	Label that appears for an element both in the Model View tree and in the diagram. You can edit this label.
To	The target for the Assignment must be a Property of the Process or the activity itself.
From	The Expression must be made up of a combination of Values, Properties, and Attributes, which are separated by operators such as add or multiply. The expression language is defined in the ExpressionLanguage attribute of the Business Process Diagram.

Property View	Description
Assign Time	<p>An Assignment may have a AssignTime setting. If the Object is an activity (Task, Sub-Process, or Process), then the Assignment must have an AssignTime. A value of Start means that the assignment shall occur at the start of the activity. This can be used to assign the higher-level (global) Properties of the Process to the (local) Properties of the activity as an input to the activity.</p> <p>A value of End means that the assignment shall occur at the end of the activity. This can be used to assign the (local) Properties of the activity to the higher-level (global) Properties of the Process as an output to the activity.</p>
Create Assignment	<p>Click  to create a new assignment for the element.</p>
<a href="#">Edit Assignment</a>	<p>When you click edit ,</p> <p>an additional tab opens where you can edit the selected assignments.</p>
Delete Assignment	Deletes the selected assignment.
Links	
Add Link	Opens the <a href="#">Create Link</a> wizard. This wizard allows you to create conceptual or usage links between elements.
Edit Link	Opens the property view for the selected link.
Delete Link	Deletes the selected link (either the link or the link target).
Show Selected Links on Active Diagram	Once you have created a link in the Diagram View, click this icon to display the links for the selected object in the diagram.
Expand All	Expands all the nodes in the tree.
Collapse All	Collapses all the nodes in the tree.
Refresh Links	Updates all the nodes in the Link Report.
Usage (CRUD)	
Usage	<p>The header displays the name of the linked element and the status of the filter (on or off).</p> <p>Receivers: Displays a list of the elements with usages (receivers). You can select multiple receivers in this list and delete all the receivers that are selected.</p> <p>Usage: Displays the usage setting (C, R, U, D). You can change the Usage attributes in this column and this change is reflected in the diagram. For example, you can change a C (Create) type to a U (Update) type.</p> <p>Usage Description: Displays the information entered in the Description text field for the target object of the usage. For example, if a usage was drawn between a task and a Data Store object, the description of the Data Store object is displayed.</p> <p>If there are no links or all the links have been filtered out, you are given the information that "No usages have been defined for this element" in the Receivers column.</p>

Property View	Description
<a href="#">Add Usage</a>	Opens the Create Usage wizard where you can create a new usage.
<a href="#">Edit Usage</a>	When you select a Receiver in the table, the edit option becomes available. Click this to open the Usage edit tab where you can edit the name of the usage. The default name is "Usage". You can also change the usage settings (Create, Read, Update, and Delete). 
Delete	When you select a Receiver in the table, the delete option becomes available. This action removes the selected receiver from the usage. 
Show Selected Usages	When you select a Receiver in the table, the Show Selected Usages option (  ) becomes available. Click this icon to display the usage for the selected receiver in the diagram, including the usage settings.
Filter Receiver Types	Opens the Usage Report Filter dialog where you can select the types of objects you want included in the Usage Report.
<a href="#">Export Usage Report</a>	You can export the Usage (CRUD) reports in the following formats: CSV, HTML, PDF, and RTF
<a href="#">Print</a>	Opens the Print dialog where you can select a printer, set preferences, select a page range and number of copies and then print.
Refresh Usage	Updates all the nodes in the Usage Report.
Impact Analysis	
Filter Designation	Indicates whether a <a href="#">Filter</a> has been set for the Impact Analysis Report. Two icons are displayed to the left of the Filter Designation indicator:  Click  to display the impact analysis information in a tree format.  Click  to display the impact analysis information in a table format.
<a href="#">Create Impact Analysis Diagram</a>	Once you create a link you can create a diagram that is a graphical representation of that link.
<a href="#">Filter</a>	Opens the Impact Analysis Filter dialog
Export	You can export and save the Impact Analysis report in the following file formats: CSV, HTML, PDF, and RTF.
Print	Opens the Print dialog where you can select a printer, set preferences, select a page range and number of copies and then print.
Expand All	Expands all the nodes in the tree.
Collapse All	Collapses all the nodes in the tree.
Refresh	Updates all the nodes in the Impact Analysis Report.



Property View	Description
Appearance	
<a href="#">Font and Color Options</a>	Use these commands to change fonts and element colors.
<a href="#">Rendering</a>	Use these commands to change the shadowing and gradient settings for an element.
<a href="#">Horizontal Alignment</a>	Use these commands to set the alignment for text labels in an element.
Diagram Display Option	Select this option to show the element label.
Apply to Diagram	Applies the formatting changes to all existing start events on the active diagram.
Restore Defaults	Restores the default settings for all changes made in the Appearance tab.
Set as Default	All formatting changes made in the Appearance tab become the default settings for new start event elements placed in the Diagram View.







### Intermediate Event

The table below describes the Property View fields available for an Intermediate Event:

Property View	Description
General	
Name	Label that appears for an element both in the Model View tree and in the diagram. You can edit this label.
Categories	You can add one or more defined Categories that can be used for purposes such as reporting and analysis.
Trigger Type	Displays the type of trigger attached to this event.
Target	A Target may be included for the Intermediate Event. The Target must be an activity (Sub-Process or Task). This means that the Intermediate Event is attached to the boundary of the activity and is used to signify an exception or compensation for that activity.
Description	
	<p>A text box where you can enter information describing or defining the project. Right-click text to open a shortcut menu. You can cut, copy, paste, and delete selected text within the Description text box. You can paste plain text from external applications.</p> <p>You can undo any action and you can select all text by pressing Ctrl+A.</p> <p>The following formatting options are available for the text: Bold, Italics, Underscore, and Strikethrough. You can also change the font color as well as the background color.</p>

Property View	Description
Notes	
	<p>A text box where you can annotate the element with additional information. Right-click text to open a shortcut menu. You can cut, copy, paste, and delete selected text within the Notes text box. You can paste plain text from external applications.</p> <p>You can undo any action and you can select all text by pressing Ctrl+A.</p> <p>The following formatting options are available for the text: Bold, Italics, Underscore, and Strikethrough. You can also change the font color as well as the background color</p>
<a href="#">Triggers</a>	
Type	When you select a trigger icon, the type you selected appear in this column.
Name	This column displays the name. Each time you add a trigger, the name is appended by a number, for example, trigger1, trigger2, etc.
Properties	<p>The type of trigger selected determines the information displayed in the description text box. Each trigger type is listed below with the information it displays:</p> <ul style="list-style-type: none"> <li>• Cancel: No description displayed.</li> <li>• Compensation: The activity that is being compensated.</li> <li>• Error: The error code in use.</li> <li>• Link: Link identification and process reference.</li> <li>• Message: Implementation type, From and To.</li> <li>• Rule: Rule Name.</li> <li>• Timer: Time cycle information.</li> </ul>
Trigger Icons	All the trigger icons are located at the bottom of the Property View. Only the triggers available for this element are available. Click the trigger icon you want to set and it appears in the grid.
<a href="#">Edit Triggers</a>	Click this option,  to open the Trigger event Property View.
Delete Trigger	Deletes the trigger type from the selected event.
Assignments	
Name	Label that appears for an element both in the Model View tree and in the diagram. You can edit this label.
To	The target for the Assignment must be a Property of the Process or the activity itself.
From	The Expression must be made up of a combination of Values, Properties, and Attributes, which are separated by operators such as add or multiply. The expression language is defined in the ExpressionLanguage attribute of the Business Process Diagram.

Property View	Description
Assign Time	<p>An Assignment may have a AssignTime setting. If the Object is an activity (Task, Sub-Process, or Process), then the Assignment must have an AssignTime. A value of Start means that the assignment shall occur at the start of the activity. This can be used to assign the higher-level (global) Properties of the Process to the (local) Properties of the activity as an input to the activity.</p> <p>A value of End means that the assignment shall occur at the end of the activity. This can be used to assign the (local) Properties of the activity to the higher-level (global) Properties of the Process as an output to the activity.</p>
Create Assignment	Click  to create a new assignment for the element.
<a href="#">Edit Assignment</a>	When you click edit  an additional tab opens where you can edit the selected assignments.
Delete Assignment	Deletes the selected assignment.
Links	
Add Link	Opens the <a href="#">Create Link</a> wizard. This wizard allows you to create conceptual or usage links between elements.
Edit Link	Opens the property view for the selected link.
Delete Link	Deletes the selected link (either the link or the link target).
Show Selected Links on Active Diagram	Once you have created a link in the Diagram View, click this icon to display the links for the selected object in the diagram.
Expand All	Expands all the nodes in the tree.
Collapse All	Collapses all the nodes in the tree.
Refresh Links	Updates all the nodes in the Link Report.
Usage (CRUD)	
Usage	<p>The header displays the name of the linked element and the status of the filter (on or off).</p> <p>Receivers: Displays a list of the elements with usages (receivers). You can select multiple receivers in this list and delete all the receivers that are selected.</p> <p>Usage: Displays the usage setting (C, R, U, D). You can change the Usage attributes in this column and this change is reflected in the diagram. For example, you can change a C (Create) type to a U (Update) type.</p> <p>Usage Description: Displays the information entered in the Description text field for the target object of the usage. For example, if a usage was drawn between a task and a Data Store object, the description of the Data Store object is displayed.</p> <p>If there are no links or all the links have been filtered out, you are given the information that "No usages have been defined for this element" in the Receivers column.</p>
<a href="#">Add Usage</a>	Opens the Create Usage wizard where you can create a new usage.

Property View	Description
<a href="#">Edit Usage</a>	When you select a Receiver in the table, the edit option becomes available. Click this to open the Usage edit tab where you can edit the name of the usage. The default name is "Usage". You can also change the usage settings (Create, Read, Update, and Delete). 
Delete	When you select a Receiver in the table, the delete option becomes available. This action removes the selected receiver from the usage. 
Show Selected Usages	When you select a Receiver in the table, the Show Selected Usages option (  ) becomes available. Click this icon to display the usage for the selected receiver in the diagram, including the usage settings.
Filter Receiver Types	Opens the Usage Report Filter dialog where you can select the types of objects you want included in the Usage Report.
<a href="#">Export Usage Report</a>	You can export the Usage (CRUD) reports in the following formats: CSV, HTML, PDF, and RTF
<a href="#">Print</a>	Opens the Print dialog where you can select a printer, set preferences, select a page range and number of copies and then print.
Refresh Usage	Updates all the nodes in the Usage Report.
Impact Analysis	
Filter Designation	Indicates whether a <a href="#">Filter</a> has been set for the Impact Analysis Report. Two icons are displayed to the left of the Filter Designation indicator:  Click  to display the impact analysis information in a tree format.  Click  to display the impact analysis information in a table format.
<a href="#">Create Impact Analysis Diagram</a>	Once you create a link you can create a diagram that is a graphical representation of that link.
<a href="#">Filter</a>	Opens the Impact Analysis Filter dialog
Export	You can export and save the Impact Analysis report in the following file formats: CSV, HTML, PDF, and RTF.
Print	Opens the Print dialog where you can select a printer, set preferences, select a page range and number of copies and then print.
Expand All	Expands all the nodes in the tree.
Collapse All	Collapses all the nodes in the tree.
Refresh	Updates all the nodes in the Impact Analysis Report.
Appearance	
<a href="#">Font and Color Options</a>	Use these commands to change fonts and element colors.





Property View	Description
<a href="#">Rendering</a>	Use these commands to change the shadowing and gradient settings for an element.
<a href="#">Horizontal Alignment</a>	Use these commands to horizontally align the text for text labels in an element.
Diagram Display Options	Select this option to show the element label.
Apply to Diagram	Applies the formatting changes to all existing intermediate events on the active diagram.
Restore Defaults	Restores the default settings for all changes made in the Appearance tab.
Set as Default	All formatting changes made in the Appearance tab become the default settings for new intermediate event elements placed in the Diagram View.







## End Event

The table below describes the Property View fields available for an End Event:

Property View	Description
General	
Name	Label that appears for an element both in the Model View tree and in the diagram. You can edit this label.
Categories	You can add one or more defined Categories that can be used for purposes such as reporting and analysis.
Trigger Type	Displays the type of trigger attached to this event.
Description	
	<p>A text box where you can enter information describing or defining the project. Right-click text to open a shortcut menu. You can cut, copy, paste, and delete selected text within the Description text box. You can paste plain text from external applications.</p> <p>You can undo any action and you can select all text by pressing Ctrl+A.</p> <p>The following formatting options are available for the text: Bold, Italics, Underscore, and Strikethrough. You can also change the font color as well as the background color.</p>

Property View	Description
Notes	
	<p>A text box where you can annotate the element with additional information. Right-click text to open a shortcut menu. You can cut, copy, paste, and delete selected text within the Notes text box. You can paste plain text from external applications.</p> <p>You can undo any action and you can select all text by pressing Ctrl+A.</p> <p>The following formatting options are available for the text: Bold, Italics, Underscore, and Strikethrough. You can also change the font color as well as the background color</p>
Results	
Type	When you select a trigger icon, the type you selected appear in this column.
Name	This column displays the name. Each time you add a trigger, the name is appended by a number, for example, trigger1, trigger2, etc.
Properties	<p>The type of trigger selected determines the information displayed in the description text box. Each trigger type is listed below with the information it displays:</p> <ul style="list-style-type: none"> <li>• Cancel: No description displayed.</li> <li>• Compensation: The activity that is being compensated.</li> <li>• Error: The error code in use.</li> <li>• Link: Link identification and process reference.</li> <li>• Message: Implementation type, From, and To.</li> <li>• Terminate: No description displayed.</li> <li>• Timer: Time cycle information.</li> </ul>
Trigger Icons	All the trigger icons are located at the bottom of the Property View. Only the triggers available for this element are available. Click the trigger icon you want to set and it appears in the grid.
<a href="#">Edit Triggers</a>	Click this option  to open the Trigger event Property View.
Delete Trigger	Deletes the trigger type from the selected event.
Assignments	
Name	Label that appears for an element both in the Model View tree and in the diagram. You can edit this label.
To	The target for the Assignment must be a Property of the Process or the activity itself.
From	The Expression must be made up of a combination of Values, Properties, and Attributes, which are separated by operators such as add or multiply. The expression language is defined in the ExpressionLanguage attribute of the Business Process Diagram.

Property View	Description
Assign Time	<p>An Assignment may have a AssignTime setting. If the Object is an activity (Task, Sub-Process, or Process), then the Assignment must have an AssignTime. A value of Start means that the assignment shall occur at the start of the activity. This can be used to assign the higher-level (global) Properties of the Process to the (local) Properties of the activity as an input to the activity.</p> <p>A value of End means that the assignment shall occur at the end of the activity. This can be used to assign the (local) Properties of the activity to the higher-level (global) Properties of the Process as an output to the activity.</p>
Create Assignment	Click  to create a new assignment for the element.
<a href="#">Edit Assignment</a>	When you click edit  an additional tab opens where you can edit the selected assignments.
Delete Assignment	Deletes the selected assignment.
Links	
Add Link	Opens the <a href="#">Create Link</a> wizard. This wizard allows you to create conceptual or usage links between elements.
Edit Link	Opens the property view for the selected link.
Delete Link	Deletes the selected link (either the link or the link target).
Show Selected Links on Active Diagram	Once you have created a link in the Diagram View, click this icon to display the links for the selected object in the diagram.
Expand All	Expands all the nodes in the tree.
Collapse All	Collapses all the nodes in the tree.
Refresh Links	Updates all the nodes in the Link Report.
Usage (CRUD)	
Usage	<p>The header displays the name of the linked element and the status of the filter (on or off).</p> <p>Receivers: Displays a list of the elements with usages (receivers). You can select multiple receivers in this list and delete all the receivers that are selected.</p> <p>Usage: Displays the usage setting (C, R, U, D). You can change the Usage attributes in this column and this change is reflected in the diagram. For example, you can change a C (Create) type to a U (Update) type.</p> <p>Usage Description: Displays the information entered in the Description text field for the target object of the usage. For example, if a usage was drawn between a task and a Data Store object, the description of the Data Store object is displayed.</p> <p>If there are no links or all the links have been filtered out, you are given the information that "No usages have been defined for this element" in the Receivers column.</p>
<a href="#">Add Usage</a>	Opens the Create Usage wizard where you can create a new usage.

Property View	Description
<a href="#">Edit Usage</a>	When you select a Receiver in the table, the edit option becomes available. Click this to open the Usage edit tab where you can edit the name of the usage. The default name is "Usage". You can also change the usage settings (Create, Read, Update, and Delete). 
Delete	When you select a Receiver in the table, the delete option becomes available. This action removes the selected receiver from the usage. 
Show Selected Usages	When you select a Receiver in the table, the Show Selected Usages option (  ) becomes available. Click this icon to display the usage for the selected receiver in the diagram, including the usage settings.
Filter Receiver Types	Opens the Usage Report Filter dialog where you can select the types of objects you want included in the Usage Report.
<a href="#">Export Usage Report</a>	You can export the Usage (CRUD) reports in the following formats: CSV, HTML, PDF, and RTF
<a href="#">Print</a>	Opens the Print dialog where you can select a printer, set preferences, select a page range and number of copies and then print.
Refresh Usage	Updates all the nodes in the Usage Report.
Impact Analysis	
Filter Designation	Indicates whether a <a href="#">Filter</a> has been set for the Impact Analysis Report. Two icons are displayed to the left of the Filter Designation indicator:  Click  to display the impact analysis information in a tree format.  Click  to display the impact analysis information in a table format.
<a href="#">Create Impact Analysis Diagram</a>	Once you create a link you can create a diagram that is a graphical representation of that link.
<a href="#">Filter</a>	Opens the Impact Analysis Filter dialog
Export	You can export and save the Impact Analysis report in the following file formats: CSV, HTML, PDF, and RTF.
Print	Opens the Print dialog where you can select a printer, set preferences, select a page range and number of copies and then print.
Expand All	Expands all the nodes in the tree.
Collapse All	Collapses all the nodes in the tree.
Refresh	Updates all the nodes in the Impact Analysis Report.
Appearance	
<a href="#">Font and Color Options</a>	Use these commands to change fonts and element colors.



Property View	Description
<a href="#">Rendering</a>	Use these commands to change the shadowing and gradient settings for an element.
<a href="#">Horizontal Alignment</a>	Use these commands to set the horizontal alignment for text labels in an element.
Diagram Display Options	Select this option to show the element label.
Apply to Diagram	Applies the formatting changes to all existing end events on the active diagram.
Restore Defaults	Restores the default settings for all changes made in the Appearance tab.
Set as Default	All formatting changes made in the Appearance tab become the default settings for new end event elements placed in the Diagram View.





## Edit Triggers

The fields available on this tab depend on the trigger selected.

Property View	Description
General	
Name	Label that appears for an element both in the Model View tree and in the diagram. You can edit this label.
Trigger Type	Displays the type of trigger attached to this event.
Activity	This field appears only when the Compensation trigger is selected.
Error Code	This field appears only when the Error trigger is selected. Enter the Error Code for the trigger.
Message	This field appears only when the Message trigger is selected. Enter the Message for the trigger.
Implementation	This field appears only when Message trigger is selected.
Link ID	This field asks for the identifier for the link. This field is available only when the Link trigger is selected.
Process Ref	A Process must be identified.
Rule Expression	This field appears only when the Rule trigger is selected.
Timedate	This field appears only when the Timer trigger is selected.
Time cycle	This field appears only when the Timer trigger is selected.





Property View	Description
Description	
	<p>A text box where you can enter information describing or defining the project. Right-click text to open a shortcut menu. You can cut, copy, paste, and delete selected text within the Description text box. You can paste plain text from external applications.</p> <p>You can undo any action and you can select all text by pressing Ctrl+A.</p> <p>The following formatting options are available for the text: Bold, Italics, Underscore, and Strikethrough. You can also change the font color as well as the background color.</p>
Notes	
	<p>A text box where you can annotate the element with additional information. Right-click text to open a shortcut menu. You can cut, copy, paste, and delete selected text within the Notes text box. You can paste plain text from external applications.</p> <p>You can undo any action and you can select all text by pressing Ctrl+A.</p> <p>The following formatting options are available for the text: Bold, Italics, Underscore, and Strikethrough. You can also change the font color as well as the background color.</p>
Links	
Add Link	Opens the <a href="#">Create Link</a> wizard. This wizard allows you to create conceptual or usage links between elements.
Edit Link	Opens the property view for the selected link.
Delete Link	Deletes the selected link (either the link or the link target).
Show Selected Links on Active Diagram	Once you have created a link in the Diagram View, click this icon to display the links for the selected object in the diagram.
Expand All	Expands all the nodes in the tree.
Collapse All	Collapses all the nodes in the tree.
Refresh Links	Updates all the nodes in the Link Report.

Property View	Description
Usage (CRUD)	
Usage	<p>The header displays the name of the linked element and the status of the filter (on or off).</p> <p><b>Receivers:</b> Displays a list of the elements with usages (receivers). You can select multiple receivers in this list and delete all the receivers that are selected.</p> <p><b>Usage:</b> Displays the usage setting (C, R, U, D). You can change the Usage attributes in this column and this change is reflected in the diagram. For example, you can change a C (Create) type to a U (Update) type.</p> <p><b>Usage Description:</b> Displays the information entered in the Description text field for the target object of the usage. For example, if a usage was drawn between a task and a Data Store object, the description of the Data Store object is displayed.</p> <p>If there are no links or all the links have been filtered out, you are given the information that "No usages have been defined for this element" in the Receivers column.</p>
<a href="#">Add Usage</a>	Opens the Create Usage wizard where you can create a new usage.
<a href="#">Edit Usage</a>	<p>When you select a Receiver in the table, the edit option becomes available. Click this to open the Usage edit tab where you can edit the name of the usage. The default name is "Usage". You can also change the usage settings (Create, Read, Update, and Delete).</p> 
Delete	<p>When you select a Receiver in the table, the delete option becomes available. This action removes the selected receiver from the usage.</p> 
Show Selected Usages	<p>When you select a Receiver in the table, the Show Selected Usages option () becomes available. Click this icon to display the usage for the selected receiver in the diagram, including the usage settings.</p>
Filter Receiver Types	Opens the Usage Report Filter dialog where you can select the types of objects you want included in the Usage Report.
<a href="#">Export Usage Report</a>	You can export the Usage (CRUD) reports in the following formats: CSV, HTML, PDF, and RTF
<a href="#">Print</a>	Opens the Print dialog where you can select a printer, set preferences, select a page range and number of copies and then print.
Refresh Usage	Updates all the nodes in the Usage Report.

Property View	Description
Impact Analysis	
Filter Designation	<p>Indicates whether a <a href="#">Filter</a> has been set for the Impact Analysis Report.</p> <p>Two icons are displayed to the left of the Filter Designation indicator:</p> <p> Click  to display the impact analysis information in a tree format.</p> <p> Click  to display the impact analysis information in a table format.</p>
<a href="#">Create Impact Analysis Diagram</a>	Once you create a link you can create a diagram that is a graphical representation of that link.
<a href="#">Filter</a>	Opens the Impact Analysis Filter dialog
Export	You can export and save the Impact Analysis report in the following file formats: CSV, HTML, PDF, and RTF.
Print	Opens the Print dialog where you can select a printer, set preferences, select a page range and number of copies and then print.
Expand All	Expands all the nodes in the tree.
Collapse All	Collapses all the nodes in the tree.
Refresh	Updates all the nodes in the Impact Analysis Report.



### Font and color options

You can edit the font settings of all element labels. The following commands are available:

Command	Icon	Description
Bold		Applies bold formatting to the label text.
Italics		Italicizes the label text.
Underline		Underlines the label text.
Strikeout		A line is drawn through the label text.





You can also change the font color, element outline color, and element fill color with the following commands:

Command	Icon	Description
Change Font Color		Opens the Color dialog. You can select an existing color or create a custom color for the color of the label font.
Change Line Color		Opens the Color dialog. You can select an existing color or create a custom color for the border of the element.
Change Fill Color		Opens the Color dialog. You can select an existing color or create a custom color for the background of the element.

## Rendering

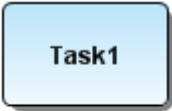

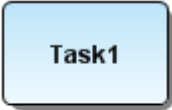
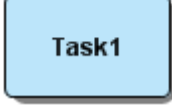
There are two commands available that affect the appearance of elements in the Diagram View:

Command	Description
Shadowed	<p>When this option is selected the element has a slight shadowed background. The Shadowed option is the default setting.</p> <div style="text-align: center;">     </div>
Gradient	<p>When this option is selected the element has a gradient shading. If it is not selected the element is a solid color. The Gradient option is the default setting.</p> <div style="text-align: center;">     </div>

## Horizontal alignment



You can justify the horizontal alignment of a text label in an element.

**NOTE:** These commands do not justify the text labels on elements that use text boxes outside the element.

Command	Icon	Description
Left Justify Text		Justifies the text on the left side of the text box.
Center Text		Centers the text in the text box.
Right Justify Text		Justifies the text on the right side of the text box.



## Vertical alignment





You can change the top to bottom alignment settings for the text label in an element.

Command	Icon	Description
Top		Places the text in the top portion of the element.
Center		Centers the text within the element.
Bottom		Places the text in the bottom portion of the element.

## Triggers

You can set trigger information for Start, Intermediate, and End Events by selecting the appropriate icon. The available triggers in the Property View depend of the element selected.

Element	Palette Icon	Description
<a href="#">Cancel</a>		This trigger is used within a Transaction Sub-process. This type of event must be attached to the boundary of a Sub-process. This trigger is available for intermediate and end events.
<a href="#">Compensation</a>		Compensation is when activities are invoked that undo an undesirable outcome. This trigger is available for intermediate and end events.
<a href="#">Error</a>		This trigger sets or catches errors. It sets an error if the Event is part of a Normal Flow. It reacts to a named error when attached to the boundary of an activity. This trigger is available for intermediate and end events.

Element	Palette Icon	Description
<a href="#">Link</a>		A mechanism for connecting the end of one Process to the start (or trigger) of another. This trigger is available for start, intermediate, and end events.
<a href="#">Message</a>		A message arrives from a participant and triggers the start of the Process. This trigger is available for start, intermediate, and end events.
<a href="#">Rule</a>		This type of event is triggered when the conditions for a rule become true. This trigger is available for start and intermediate events.
<a href="#">Terminate</a>		All activities in the Process should be ended immediately. The Process is ended without compensation or event handling. This trigger is available for and end event.
<a href="#">Timer</a>		A specific time-date or a specific cycle (e.g., every Friday at 10:00 a.m.) is set that triggers the start of the Process. This trigger is available for start and intermediate events.

## Activities

An Activity is work that is performed within a business process and be represented by a set of graphical objects usually composed of three main activities: [Task](#), [Embedded Sub-processes](#), and [Independent Sub-processes](#).

### Task



The table below describes the Property View fields available for a Task:



Property View	Description
General	
Name	Label that appears for an element both in the Model View tree and in the diagram. You can edit this label.
Categories	You can add one or more defined Categories that can be used for purposes such as reporting and analysis.

Property View	Description
Task Type	<p>Task Type may be set to the following attributes:</p> <p>Manual: A Manual Task is expected to be performed without the aid of any business process execution engine or any application.</p> <p>None: No task type designation is set.</p> <p>Receive: A simple Task that is designed to wait for a message to arrive from an external participant. Once the message has been received, the Task is completed.</p> <p>Reference: This task references another activity that has been defined. If the two (or more) activities share the exact same behavior, then by one referencing the other, the attributes that define the behavior are only created once and maintained in only one location.</p> <p>Script: A Script Task is executed by a business process engine. The modeler or implementer defines a script in a language that the engine can interpret. When the Task is ready to start, the engine executes the script. When the script is completed, the Task is also completed.</p> <p>Send: A simple Task that is designed to send a message to an external participant. Once the message has been sent, the Task is completed.</p> <p>Service: A Service Task is a Task that provides some sort of service, which could be a Web service or an automated application. This is the default setting.</p> <p>User: A typical “workflow” task where a human performer performs the Task with the assistance of a software application and is scheduled through a task list manager of some sort.</p> <p>The TaskType is impacted by the Message Flow to and/or from the Task, if Message Flows are used. A TaskType of Receive must not have an outgoing Message Flow. A TaskType of Send must not have an incoming Message Flow. A TaskType of Script, Manual, or None must not have an incoming or an outgoing Message Flow. The TaskType list may be extended to include new types.</p>
In Message	<p>A Message for the InMessage attribute must be entered. This indicates that the Message will be sent at the start of the Task, after the availability of any defined InputSets. A corresponding outgoing Message Flow MAY be shown on the diagram. However, the display of the Message Flow is not required.</p>
Out Message	<p>A Message for the OutMessage attribute MUST be entered. The arrival of this message marks the completion of the Task, which may cause the production of an OutputSet. A corresponding incoming Message Flow may be shown on the diagram. However, the display of the Message Flow is not required.</p>
<a href="#">Implementation</a>	<p>This attribute specifies the technology that will be used to send and receive the messages. Web Service is the default technology.</p>
Instantiate	<p>This attribute is available when you select the Task Type “Receive”.</p>





Property View	Description
Script	This field is available when you select the Task Type "Script".
Message	This field is available when you select the Task Type "Receive" and "Send".
Task Reference	When you select the Task Type of "Reference", a Task Reference drop-down box opens with the available tasks listed.
Description	
	<p>A text box where you can enter information describing or defining the project. Right-click text to open a shortcut menu. You can cut, copy, paste, and delete selected text within the Description text box. You can paste plain text from external applications.</p> <p>You can undo any action and you can select all text by pressing Ctrl+A.</p> <p>The following formatting options are available for the text: Bold, Italics, Underscore, and Strikethrough. You can also change the font color as well as the background color.</p>
Notes	
	<p>A text box where you can annotate the element with additional information. Right-click text to open a shortcut menu. You can cut, copy, paste, and delete selected text within the Notes text box. You can paste plain text from external applications.</p> <p>You can undo any action and you can select all text by pressing Ctrl+A.</p> <p>The following formatting options are available for the text: Bold, Italics, Underscore, and Strikethrough. You can also change the font color as well as the background color.</p>
Activity	
Status	<p>The Status of a Process is determined when the Process is being executed by a process engine. The Status of a Process can be used within Assignment Expressions.</p> <p>The status settings available are: None, Aborted, Aborting, Active, or Cancelled.</p>
Start Quantity	The default value is 1. The value must not be less than 1. This attribute defines the number of Tokens that must arrive from a single Sequence Flow before the activity can begin.
Loop Type	<p>LoopType is an attribute and is by default None, but may be set to Standard or Multi Instance. If so, the Loop marker shall be placed at the bottom center of the activity shape.</p> <p>A Task of type Receive that has its Instantiate attribute set to True must not have a Standard or MultiInstance Loop Type.</p>
<a href="#">Standard Loop Type Properties</a>	A Standard Loop activity has a boolean expression that is evaluated after each cycle of the loop. If the expression is still True, then the loop continues.

Property View	Description
<a href="#">Multiple Instance Loop</a> <a href="#">Type Properties</a>	Multi-Instance loops reflect the programming construct for each. The loop expression for a Multi-Instance loop is a numeric expression evaluated only once before the activity is performed.
Properties	
Name	Modeler-defined Properties may be added to an activity. These Properties are "local" to the activity and are only for use within the processing of the activity. The fully delineated name of these properties is "<process name>.<activity name>.<property name>". You can add, <a href="#">edit</a> and delete these properties.
Type	Each Property has a Type (for example, type="String"). A Property may be of type Set, which allows child Properties.
Correlation	If the ConditionType attribute is set to Expression, then the ConditionExpression attribute must be defined. Otherwise, it is not valid. This attribute is included for mapping to BPEL4WS. The Property will map to a <i>correlationSet</i> and the child Properties will be <i>properties</i> of that <i>correlationSet</i> .
Create Property	Click  to create a new property for the task.
IORules	
Expression	Enter the expression that defines the relationship between one InputSet and one OutputSet. That is, if the activity is instantiated with a specified InputSet, then the output of the activity MUST produce the specified OutputSet. Zero or more IORules may be entered.
Input Sets	
Name	The InputSets attribute defines the data requirements for input to the activity. Zero or more InputSets MAY be defined. Each Input set is sufficient to allow the activity to be performed (if it has first been instantiated by the appropriate signal arriving from an incoming Sequence Flow).
Output Sets	
Name	The OutputSets attribute defines the data requirements for output from the activity. Zero or more OutputSets may be defined. At the completion of the activity, only one of the OutputSets may be produced--It is up to the implementation of the activity to determine which set will be produced. However, the IORules attribute may indicate a relationship between an OutputSet and an InputSet that started the activity.
Assignments	
Name	Label that appears for an element both in the Model View tree and in the diagram. You can edit this label.
To	The target for the Assignment must be a Property of the Process or the activity itself.

Property View	Description
From	The Expression must be made up of a combination of Values, Properties, and Attributes, which are separated by operators such as add or multiply. The expression language is defined in the ExpressionLanguage attribute of the Business Process Diagram.
Assign Time	<p>An Assignment may have a AssignTime setting. If the Object is an activity (Task, Sub-Process, or Process), then the Assignment must have an AssignTime. A value of Start means that the assignment shall occur at the start of the activity. This can be used to assign the higher-level (global) Properties of the Process to the (local) Properties of the activity as an input to the activity.</p> <p>A value of End means that the assignment shall occur at the end of the activity. This can be used to assign the (local) Properties of the activity to the higher-level (global) Properties of the Process as an output to the activity.</p>
Create Assignment	Click  to create a new assignment for the element.
<a href="#">Edit Assignment</a>	When you click edit  an additional tab opens where you can edit the selected assignments.
Delete Assignment	Deletes the selected assignment.
Links	
Add Link	Opens the <a href="#">Create Link</a> wizard. This wizard allows you to create conceptual or usage links between elements.
Edit Link	Opens the property view for the selected link.
Delete Link	Deletes the selected link (either the link or the link target).
Show Selected Links on Active Diagram	Once you have created a link in the Diagram View, click this icon to display the links for the selected object in the diagram.
Expand All	Expands all the nodes in the tree.
Collapse All	Collapses all the nodes in the tree.
Refresh Links	Updates all the nodes in the Link Report.

Property View	Description
Usage (CRUD)	
Usage	<p>The header displays the name of the linked element and the status of the filter (on or off).</p> <p>Receivers: Displays a list of the elements with usages (receivers). You can select multiple receivers in this list and delete all the receivers that are selected.</p> <p>Usage: Displays the usage setting (C, R, U, D). You can change the Usage attributes in this column and this change is reflected in the diagram. For example, you can change a C (Create) type to a U (Update) type.</p> <p>Usage Description: Displays the information entered in the Description text field for the target object of the usage. For example, if a usage was drawn between a task and a Data Store object, the description of the Data Store object is displayed.</p> <p>If there are no links or all the links have been filtered out, you are given the information that "No usages have been defined for this element" in the Receivers column.</p>
<a href="#">Add Usage</a>	Opens the Create Usage wizard where you can create a new usage.
<a href="#">Edit Usage</a>	<p>When you select a Receiver in the table, the edit option becomes available. Click this to open the Usage edit tab where you can edit the name of the usage. The default name is "Usage". You can also change the usage settings (Create, Read, Update, and Delete).</p> 
Delete	<p>When you select a Receiver in the table, the delete option becomes available. This action removes the selected receiver from the usage.</p> 
Show Selected Usages	<p>When you select a Receiver in the table, the Show Selected Usages option (  ) becomes available. Click this icon to display the usage for the selected receiver in the diagram, including the usage settings.</p>
Filter Receiver Types	Opens the Usage Report Filter dialog where you can select the types of objects you want included in the Usage Report.
<a href="#">Export Usage Report</a>	You can export the Usage (CRUD) reports in the following formats: CSV, HTML, PDF, and RTF
<a href="#">Print</a>	Opens the Print dialog where you can select a printer, set preferences, select a page range and number of copies and then print.
Refresh Usage	Updates all the nodes in the Usage Report.



Property View	Description
Impact Analysis	
Filter Designation	<p>Indicates whether a <a href="#">Filter</a> has been set for the Impact Analysis Report.</p> <p>Two icons are displayed to the left of the Filter Designation indicator:</p> <p> Click  to display the impact analysis information in a tree format.</p> <p> Click  to display the impact analysis information in a table format.</p>
<a href="#">Create Impact Analysis Diagram</a>	Once you create a link you can create a diagram that is a graphical representation of that link.
<a href="#">Filter</a>	Opens the Impact Analysis Filter dialog
Export	You can export and save the Impact Analysis report in the following file formats: CSV, HTML, PDF, and RTF.
Print	Opens the Print dialog where you can select a printer, set preferences, select a page range and number of copies and then print.
Expand All	Expands all the nodes in the tree.
Collapse All	Collapses all the nodes in the tree.
Refresh	Updates all the nodes in the Impact Analysis Report.
Appearance	
<a href="#">Font and Color Options</a>	Use these commands to change fonts and element colors.
<a href="#">Rendering</a>	Use these commands to change the shadowing and gradient settings for an element.
<a href="#">Horizontal Alignment</a>	Use these commands to set the justification for text labels in an element.
<a href="#">Vertical Alignment</a>	Use these commands to set the alignment (top, centered or bottom) of a text label within an element.
Diagram Display Options	Select this option to show the element label.
Line Display Options	Select the width of the border from the drop-down list. You can select from 1 to 5 pixels.
Apply to Diagram	Applies the formatting changes to all existing tasks on the active diagram.
Restore Defaults	Restores the default settings for all changes made in the Appearance tab.
Set as Default	All formatting changes made in the Appearance tab become the default settings for new task elements placed in the Diagram View.

## Implementation

If you select Web Service in the Implementation field, you can set properties in an additional Property View.

Property View	Description
Name	Label that appears for an element both in the Model View tree and in the diagram. You can edit this label.
Participant	The Participant attribute is mapped to the <i>partnerLink</i> attribute of the BPEL4WS activity.
Interface	The Interface attribute is mapped to the <i>portType</i> attribute of the BPEL4WS activity.
Operation	The Operation attribute is mapped to the <i>operation</i> attribute of the BPEL4WS activity.

## Standard Loop Type Properties

If you select Standard in the Loop Type field, you can set properties in an additional Property View.

Property View	Description
Condition	Standard Loops must have a boolean Expression to be evaluated, plus the timing when the expression shall be evaluated.
Counter	The LoopCounter attribute is used at runtime to count the number of loops and is automatically updated by the process engine. The LoopCounter attribute must be incremented at the start of a loop. The modeler may use the attribute in the LoopCondition Expression.
Maximum	The Maximum an optional attribute that provides is a simple way to add a cap to the number of loops. This shall be added to the Expression defined in the LoopCondition.
Test time	The expressions that are evaluated before the activity begins are equivalent to a programming while function. The expression that are evaluated after the activity finishes are equivalent to a programming until function.

## Multiple Instance Loop Type Properties

If you select Multiple Instance in the Loop Type field, you can set properties in an additional Property View.

Property View	Description
Condition	MultilInstance Loops must have a numeric Expression to be evaluated--the Expression must resolve to an integer.

Property View	Description
Ordering	This applies to only Multi-Instance Loops. The MI_Ordering attribute defines whether the loop instances will be performed sequentially or in parallel. Sequential MI_Ordering is a more traditional loop. Parallel MI_Ordering is equivalent to multi-instance specifications that other notations, such as UML Activity Diagrams use. If set to Parallel, the Parallel marker shall replace the Loop Marker at the bottom center of the activity shape.
Counter	The LoopCounter attribute is only applied for Sequential Multi-Instance Loops and for processes that are being executed by a process engine. The attribute is updated at runtime by a process engine to count the number of loops as they occur. The LoopCounter attribute must be incremented at the start of a loop. Unlike a Standard loop, you do not use this attribute in the MI_Condition Expression, but it can be used for tracking the status of a loop.
Flow Condition	<p>This attribute is equivalent to using a Gateway to control the flow past a set of parallel paths. An MI_FlowCondition of "None" is the same as uncontrolled flow (no Gateway) and means that all activity instances shall generate a token that will continue when that instance is completed. An MI_FlowCondition of "One" is the same as an Exclusive Gateway and means that the Token shall continue past the activity after only one of the activity instances has completed.</p> <p>The activity continues its other instances, but additional Tokens must not be passed from the activity. An MI_FlowCondition of "All" is the same as a Parallel Gateway and means that the Token shall continue past the activity after all of the activity instances have completed. An MI_FlowCondition of "Complex" is the same as a Complex Gateway. The ComplexMI_FlowCondition attribute will determine the Token flow.</p>
Complex Flow Condition	If the MI_FlowCondition attribute is set to "Complex," then an Expression must be entered. This Expression may reference Process data. The expression shall determine when and how many Tokens will continue past the activity.



### Embedded Sub-processes



The table below describes the Property View fields available for Sub-processes:





Property View	Description
General	
Name	Label that appears for an element both in the Model View tree and in the diagram. You can edit this label.
Categories	You can add one or more defined Categories that can be used for purposes such as reporting and analysis.
Sub-Process type:	This maps to a BPEL4WS scope element. The scope is not an independent <i>process</i> and will share the <i>process variables</i> of the higher-level <i>process</i> .

Property View	Description
<a href="#">Ad hoc</a>	<p>Ad hoc is a boolean attribute, which has a default of False. This specifies whether the Embedded Sub-Process is Ad Hoc or not. The activities within an Ad Hoc Embedded Sub-Process are not controlled or sequenced in a particular order, there performance is determined by the performers of the activities.</p> <p><b>Note:</b> You can set this attribute for multiple subprocesses.</p>
<a href="#">Transaction Properties</a>	<p>This option determines whether or not the behavior of the Sub-Process will follow the behavior of a Transaction.</p> <p><b>Note:</b> You can set this attribute for multiple subprocesses.</p>
Description	
	<p>A text box where you can enter information describing or defining the project. Right-click text to open a shortcut menu. You can cut, copy, paste, and delete selected text within the Description text box. You can paste plain text from external applications.</p> <p>You can undo any action and you can select all text by pressing Ctrl+A.</p> <p>The following formatting options are available for the text: Bold, Italics, Underscore, and Strikethrough. You can also change the font color as well as the background color.</p>
Notes	
	<p>A text box where you can annotate the element with additional information. Right-click text to open a shortcut menu. You can cut, copy, paste, and delete selected text within the Notes text box. You can paste plain text from external applications.</p> <p>You can undo any action and you can select all text by pressing Ctrl+A.</p> <p>The following formatting options are available for the text: Bold, Italics, Underscore, and Strikethrough. You can also change the font color as well as the background color</p>
Activity	
Status	<p>The Status of a Process is determined when the Process is being executed by a process engine. The Status of a Process can be used within Assignment Expressions.</p> <p>The status settings available are: None, Aborted, Aborting, Active, or Cancelled.</p>
Start Quantity	<p>The default value is 1. The value must not be less than 1. This attribute defines the number of Tokens that must arrive from a single Sequence Flow before the activity can begin.</p>

Property View	Description
Loop Type	<p>LoopType is an attribute and is by default <i>None</i>, but may be set to <i>Standard</i> or <i>MultiInstance</i>. If so, the Loop marker shall be placed at the bottom center of the activity shape.</p> <p>A Task of type <i>Receive</i> that has its <i>Instantiate</i> attribute set to <i>True</i> must not have a <i>Standard</i> or <i>MultiInstance</i> Loop Type.</p>
<a href="#">Standard Loop Type Properties</a>	A Standard Loop activity has a boolean expression that is evaluated after each cycle of the loop. If the expression is still <i>True</i> , then the loop continues.
<a href="#">Multiple Instance Loop Type Properties</a>	Multi-Instance loops reflect the programming construct for each. The loop expression for a Multi-Instance loop is a numeric expression evaluated only once before the activity is performed.
Properties	
Name	Modeler-defined Properties may be added to an activity. These Properties are "local" to the activity and are only for use within the processing of the activity. The fully delineated name of these properties is "<process name>.<activity name>.<property name>". You can add, <a href="#">edit</a> and delete these properties.
Type	Each Property has a Type (for example, type="String"). A Property may be of type <i>Set</i> , which allows child Properties.
Correlation	If the <i>ConditionType</i> attribute is set to <i>Expression</i> , then the <i>ConditionExpression</i> attribute must be defined. Otherwise, it is not valid. This attribute is included for mapping to BPEL4WS. The Property will map to a <i>correlationSet</i> and the child Properties will be <i>properties</i> of that <i>correlationSet</i> .
IORules	
Expression	The <i>IORules</i> attribute is an expression that defines the relationship between one <i>InputSet</i> and one <i>OutputSet</i> . That is, if the activity is instantiated with a specified <i>InputSet</i> , then the output of the activity must produce the specified <i>OutputSet</i> . Zero or more <i>IORules</i> may be entered.
Input Sets	
Name	The <i>InputSets</i> attribute defines the data requirements for input to the activity. Zero or more <i>InputSets</i> MAY be defined. Each Input set is sufficient to allow the activity to be performed (if it has first been instantiated by the appropriate signal arriving from an incoming Sequence Flow).
Output Sets	
Name	The <i>OutputSets</i> attribute defines the data requirements for output from the activity. Zero or more <i>OutputSets</i> may be defined. At the completion of the activity, only one of the <i>OutputSets</i> may be produced--It is up to the implementation of the activity to determine which set will be produced. However, the <i>IORules</i> attribute may indicate a relationship between an <i>OutputSet</i> and an <i>InputSet</i> that started the activity.

Property View	Description
<b>Assignments</b>	
Name	Label that appears for an element both in the Model View tree and in the diagram. You can edit this label.
To	The target for the Assignment must be a Property of the Process or the activity itself.
From	The Expression must be made up of a combination of Values, Properties, and Attributes, which are separated by operators such as add or multiply. The expression language is defined in the ExpressionLanguage attribute of the Business Process Diagram.
Assign Time	<p>An Assignment may have a AssignTime setting. If the Object is an activity (Task, Sub-Process, or Process), then the Assignment must have an AssignTime. A value of Start means that the assignment shall occur at the start of the activity. This can be used to assign the higher-level (global) Properties of the Process to the (local) Properties of the activity as an input to the activity.</p> <p>A value of End means that the assignment shall occur at the end of the activity. This can be used to assign the (local) Properties of the activity to the higher-level (global) Properties of the Process as an output to the activity.</p>
Create Assignment	Click  to create a new assignment for the element.
<a href="#">Edit Assignment</a>	When you click edit  an additional tab opens where you can edit the selected assignments.
Delete Assignment	Deletes the selected assignment.
<b>Graphical Elements</b>	
Name	Modeler-defined Properties may be added to an activity. These Properties are "local" to the activity and are only for use within the processing of the activity. The fully delineated name of these properties is "<process name>.<activity name>.<property name>". You can add, <a href="#">edit</a> and delete these properties.
<b>Links</b>	
Add Link	Opens the <a href="#">Create Link</a> wizard. This wizard allows you to create conceptual or usage links between elements.
Edit Link	Opens the property view for the selected link.
Delete Link	Deletes the selected link (either the link or the link target).
Show Selected Links on Active Diagram	Once you have created a link in the Diagram View, click this icon to display the links for the selected object in the diagram.
Expand All	Expands all the nodes in the tree.
Collapse All	Collapses all the nodes in the tree.
Refresh Links	Updates all the nodes in the Link Report.

Property View	Description
Usage (CRUD)	
Usage	<p>The header displays the name of the linked element and the status of the filter (on or off).</p> <p>Receivers: Displays a list of the elements with usages (receivers). You can select multiple receivers in this list and delete all the receivers that are selected.</p> <p>Usage: Displays the usage setting (C, R, U, D). You can change the Usage attributes in this column and this change is reflected in the diagram. For example, you can change a C (Create) type to a U (Update) type.</p> <p>Usage Description: Displays the information entered in the Description text field for the target object of the usage. For example, if a usage was drawn between a task and a Data Store object, the description of the Data Store object is displayed.</p> <p>If there are no links or all the links have been filtered out, you are given the information that "No usages have been defined for this element" in the Receivers column.</p>
<a href="#">Add Usage</a>	Opens the Create Usage wizard where you can create a new usage.
<a href="#">Edit Usage</a>	<p>When you select a Receiver in the table, the edit option becomes available. Click this to open the Usage edit tab where you can edit the name of the usage. The default name is "Usage". You can also change the usage settings (Create, Read, Update, and Delete).</p> 
Delete	<p>When you select a Receiver in the table, the delete option becomes available. This action removes the selected receiver from the usage.</p> 
Show Selected Usages	<p>When you select a Receiver in the table, the Show Selected Usages option () becomes available. Click this icon to display the usage for the selected receiver in the diagram, including the usage settings.</p>
Filter Receiver Types	Opens the Usage Report Filter dialog where you can select the types of objects you want included in the Usage Report.
<a href="#">Export Usage Report</a>	You can export the Usage (CRUD) reports in the following formats: CSV, HTML, PDF, and RTF
<a href="#">Print</a>	Opens the Print dialog where you can select a printer, set preferences, select a page range and number of copies and then print.
Refresh Usage	Updates all the nodes in the Usage Report.

Property View	Description
Impact Analysis	
Filter Designation	<p>Indicates whether a <a href="#">Filter</a> has been set for the Impact Analysis Report.</p> <p>Two icons are displayed to the left of the Filter Designation indicator:</p> <p> Click  to display the impact analysis information in a tree format.</p> <p> Click  to display the impact analysis information in a table format.</p>
<a href="#">Create Impact Analysis Diagram</a>	Once you create a link you can create a diagram that is a graphical representation of that link.
<a href="#">Filter</a>	Opens the Impact Analysis Filter dialog
Export	You can export and save the Impact Analysis report in the following file formats: CSV, HTML, PDF, and RTF.
Print	Opens the Print dialog where you can select a printer, set preferences, select a page range and number of copies and then print.
Expand All	Expands all the nodes in the tree.
Collapse All	Collapses all the nodes in the tree.
Refresh	Updates all the nodes in the Impact Analysis Report.
Appearance	
<a href="#">Font and Color Options</a>	Use these commands to change fonts and element colors.
<a href="#">Rendering</a>	Use these commands to change the shadowing and gradient settings for an element.
<a href="#">Horizontal Alignment</a>	Use these commands to set the justification for text labels in an element.
<a href="#">Vertical Alignment</a>	Use these commands to set the alignment (top, centered or bottom) of a text label within an element.
Diagram Display Options	Select this option to show the element label.
Line Display Options	Select the width of the border from the drop-down list. You can select from 1 to 5 pixels.
Apply to Diagram	Applies the formatting changes to all existing tasks on the active diagram.
Restore Defaults	Restores the default settings for all changes made in the Appearance tab.
Set as Default	All formatting changes made in the Appearance tab become the default settings for new task elements placed in the Diagram View.





## Independent Sub-processes







The table below describes the Property View fields available for Sub-processes:

Property View	Description
General	
Name	Label that appears for an element both in the Model View tree and in the diagram. You can edit this label.
Categories	You can add one or more defined Categories that can be used for purposes such as reporting and analysis.
Sub-Process type:	<p>BPEL4WS does not have a sub-process element. Thus, Independent Sub-Processes must map to a BPEL4WS <i>process</i>. That is, the contents of the Sub-Process, whether it is expanded or collapsed, will be contained within a separate <i>process</i>. The DiagramRef and ProcessRef attributes will identify the <i>process</i> that will be used for the mapping to the BPEL4WS <i>process</i>.</p> <p>The attributes of the other BPEL4WS <i>process</i> element will be filled from the mapping of the referenced Process. The Sub-Process object itself maps to an <i>invoke</i> activity that "calls" the <i>process</i>.</p>
<a href="#">Diagram Ref</a>	The Business Process Diagram must be identified.
<a href="#">Process Ref</a>	A Process must be identified.
<a href="#">Transaction Properties</a>	<p>Transaction determines whether or not the behavior of the Sub-Process will follow the behavior of a Transaction.</p> <p><b>Note:</b> You can set this attribute for multiple subprocesses.</p>
Description	
	<p>A text box where you can enter information describing or defining the project. Right-click text to open a shortcut menu. You can cut, copy, paste, and delete selected text within the Description text box. You can paste plain text from external applications.</p> <p>You can undo any action and you can select all text by pressing Ctrl+A.</p> <p>The following formatting options are available for the text: Bold, Italics, Underscore, and Strikethrough. You can also change the font color as well as the background color.</p>

Property View	Description
Notes	
	<p>A text box where you can annotate the element with additional information. Right-click text to open a shortcut menu. You can cut, copy, paste, and delete selected text within the Notes text box. You can paste plain text from external applications.</p> <p>You can undo any action and you can select all text by pressing Ctrl+A.</p> <p>The following formatting options are available for the text: Bold, Italics, Underscore, and Strikethrough. You can also change the font color as well as the background color</p>
Activity	
Status	<p>The Status of a Process is determined when the Process is being executed by a process engine. The Status of a Process can be used within Assignment Expressions.</p> <p>The status settings available are: None, Aborted, Aborting, Active, or Cancelled.</p>
Start Quantity	<p>The default value is 1. The value must not be less than 1. This attribute defines the number of Tokens that must arrive from a single Sequence Flow before the activity can begin.</p>
Loop Type	<p>LoopType is an attribute and is by default <i>None</i>, but may be set to <i>Standard</i> or <i>MultiInstance</i>. If so, the Loop marker shall be placed at the bottom center of the activity shape.</p> <p>A Task of type <i>Receive</i> that has its <i>Instantiate</i> attribute set to <i>True</i> must not have a <i>Standard</i> or <i>MultiInstance</i> Loop Type.</p>
<a href="#">Standard Loop Type Properties</a>	<p>A Standard Loop activity has a boolean expression that is evaluated after each cycle of the loop. If the expression is still <i>True</i>, then the loop continues.</p>
<a href="#">Multiple Instance Loop Type Properties</a>	<p>Multi-Instance loops reflect the programming construct for each. The loop expression for a Multi-Instance loop is a numeric expression evaluated only once before the activity is performed.</p>
Properties	
Name	<p>Modeler-defined Properties may be added to an activity. These Properties are "local" to the activity and are only for use within the processing of the activity. The fully delineated name of these properties is "&lt;process name&gt;.&lt;activity name&gt;.&lt;property name&gt;". You can add, <a href="#">edit</a> and delete these properties.</p>
Type	<p>Each Property has a Type (for example, type="String"). A Property may be of type <i>Set</i>, which allows child Properties.</p>
Correlation	<p>If the <i>ConditionType</i> attribute is set to <i>Expression</i>, then the <i>ConditionExpression</i> attribute must be defined. Otherwise, it is not valid. This attribute is included for mapping to BPEL4WS. The Property will map to a <i>correlationSet</i> and the child Properties will be <i>properties</i> of that <i>correlationSet</i>.</p>

Property View	Description
IORules	
Expression	The IORules attribute is an expression that defines the relationship between one InputSet and one OutputSet. That is, if the activity is instantiated with a specified InputSet, then the output of the activity must produce the specified OutputSet. Zero or more IORules may be entered.
Input Sets	
Name	The InputSets attribute defines the data requirements for input to the activity. Zero or more InputSets MAY be defined. Each Input set is sufficient to allow the activity to be performed (if it has first been instantiated by the appropriate signal arriving from an incoming Sequence Flow).
Output Sets	
Name	The OutputSets attribute defines the data requirements for output from the activity. Zero or more OutputSets may be defined. At the completion of the activity, only one of the OutputSets may be produced--It is up to the implementation of the activity to determine which set will be produced. However, the IORules attribute may indicate a relationship between an OutputSet and an InputSet that started the activity.
Input Property Maps	
Expression	Multiple input mappings may be made between properties of the Independent Sub-Process and the properties of the Process referenced by this object. These mappings are in the form of an expression (although a modeling tool can present this to a modeler in any number of ways).
Output Property Maps	
Expression	Multiple output mappings MAY be made between properties of the Independent Sub-Process and the properties of the Process referenced by this object. These mappings are in the form of an expression (although a modeling tool can present this to a modeler in any number of ways).
Assignments	
Name	Label that appears for an element both in the Model View tree and in the diagram. You can edit this label.
To	The target for the Assignment must be a Property of the Process or the activity itself.
From	The Expression must be made up of a combination of Values, Properties, and Attributes, which are separated by operators such as add or multiply. The expression language is defined in the ExpressionLanguage attribute of the Business Process Diagram.

Property View	Description
Assign Time	<p>An Assignment may have a AssignTime setting. If the Object is an activity (Task, Sub-Process, or Process), then the Assignment must have an AssignTime. A value of Start means that the assignment shall occur at the start of the activity. This can be used to assign the higher-level (global) Properties of the Process to the (local) Properties of the activity as an input to the activity.</p> <p>A value of End means that the assignment shall occur at the end of the activity. This can be used to assign the (local) Properties of the activity to the higher-level (global) Properties of the Process as an output to the activity.</p>
Create Assignment	Click  to create a new assignment for the element.
<a href="#">Edit Assignment</a>	When you click edit  , an additional tab opens where you can edit the selected assignments.
Delete Assignment	Deletes the selected assignment.
Links	
Add Link	Opens the <a href="#">Create Link</a> wizard. This wizard allows you to create conceptual or usage links between elements.
Edit Link	Opens the property view for the selected link.
Delete Link	Deletes the selected link (either the link or the link target).
Show Selected Links on Active Diagram	Once you have created a link in the Diagram View, click this icon to display the links for the selected object in the diagram.
Expand All	Expands all the nodes in the tree.
Collapse All	Collapses all the nodes in the tree.
Refresh Links	Updates all the nodes in the Link Report.
Usage (CRUD)	
Usage	<p>The header displays the name of the linked element and the status of the filter (on or off).</p> <p>Receivers: Displays a list of the elements with usages (receivers). You can select multiple receivers in this list and delete all the receivers that are selected.</p> <p>Usage: Displays the usage setting (C, R, U, D). You can change the Usage attributes in this column and this change is reflected in the diagram. For example, you can change a C (Create) type to a U (Update) type.</p> <p>Usage Description: Displays the information entered in the Description text field for the target object of the usage. For example, if a usage was drawn between a task and a Data Store object, the description of the Data Store object is displayed.</p> <p>If there are no links or all the links have been filtered out, you are given the information that "No usages have been defined for this element" in the Receivers column.</p>

Property View	Description
<a href="#">Add Usage</a>	Opens the Create Usage wizard where you can create a new usage.
<a href="#">Edit Usage</a>	When you select a Receiver in the table, the edit option becomes available. Click this to open the Usage edit tab where you can edit the name of the usage. The default name is "Usage". You can also change the usage settings (Create, Read, Update, and Delete). 
Delete	When you select a Receiver in the table, the delete option becomes available. This action removes the selected receiver from the usage. 
Show Selected Usages	When you select a Receiver in the table, the Show Selected Usages option (  ) becomes available. Click this icon to display the usage for the selected receiver in the diagram, including the usage settings.
Filter Receiver Types	Opens the Usage Report Filter dialog where you can select the types of objects you want included in the Usage Report.
<a href="#">Export Usage Report</a>	You can export the Usage (CRUD) reports in the following formats: CSV, HTML, PDF, and RTF
<a href="#">Print</a>	Opens the Print dialog where you can select a printer, set preferences, select a page range and number of copies and then print.
Refresh Usage	Updates all the nodes in the Usage Report.
Impact Analysis	
Filter Designation	Indicates whether a <a href="#">Filter</a> has been set for the Impact Analysis Report. Two icons are displayed to the left of the Filter Designation indicator:  Click  to display the impact analysis information in a tree format.  Click  to display the impact analysis information in a table format.
<a href="#">Create Impact Analysis Diagram</a>	Once you create a link you can create a diagram that is a graphical representation of that link.
<a href="#">Filter</a>	Opens the Impact Analysis Filter dialog
Export	You can export and save the Impact Analysis report in the following file formats: CSV, HTML, PDF, and RTF.
Print	Opens the Print dialog where you can select a printer, set preferences, select a page range and number of copies and then print.
Expand All	Expands all the nodes in the tree.
Collapse All	Collapses all the nodes in the tree.
Refresh	Updates all the nodes in the Impact Analysis Report.



Property View	Description
Appearance	
<a href="#">Font and Color Options</a>	Use these commands to change fonts and element colors.
<a href="#">Rendering</a>	Use these commands to change the shadowing and gradient settings for an element.
<a href="#">Horizontal Alignment</a>	Use these commands to set the justification for text labels in an element.
<a href="#">Vertical Alignment</a>	Use these commands to set the alignment (top, centered or bottom) of a text label within an element.
Diagram Display Options	Select this option to show the element label.
Line Display Options	Select the width of the border from the drop-down list. You can select from 1 to 5 pixels.
Apply to Diagram	Applies the formatting changes to all existing independent sub-processes on the active diagram.
Restore Defaults	Restores the default settings for all changes made in the Appearance tab.
Set as Default	All formatting changes made in the Appearance tab become the default settings for new independent sub-processes placed in the Diagram View.

### Diagram ref properties





When you click edit  an additional tab opens where you can edit the properties for the selected diagram.

Property View	Description
General	
Name	Label that appears for an element both in the Model View tree and in the diagram. You can edit this label.
Location	Displays the path where the diagram file, with the file extension of .edsb, is stored.
Version	This text field displays the Version number of ER/Studio BA.
Diagram Version	Displays the diagram version number.
Author	This text field contains the name of the author of the Diagram.
Creation Date	This displays the date on which the Diagram was created (for this Version).
Last Modification Date	This defines the date on which the Diagram was last modified (for this Version).
Language	This text field contains the name of the language in which text is written. The default is English.
Expression Language	A Language may be provided so that the syntax of expressions used in the Diagram can be understood.
Query Language	A Language may be provided so that the syntax of queries used in the Diagram can be understood.

Property View	Description
Description	
	<p>A text box where you can enter information describing or defining the project. Right-click text to open a shortcut menu. You can cut, copy, paste, and delete selected text within the Description text box. You can paste plain text from external applications.</p> <p>You can undo any action and you can select all text by pressing Ctrl+A.</p> <p>The following formatting options are available for the text: Bold, Italics, Underscore, and Strikethrough. You can also change the font color as well as the background color.</p>
Notes	
	<p>A text box where you can annotate the element with additional information. Right-click text to open a shortcut menu. You can cut, copy, paste, and delete selected text within the Notes text box. You can paste plain text from external applications.</p> <p>You can undo any action and you can select all text by pressing Ctrl+A.</p> <p>The following formatting options are available for the text: Bold, Italics, Underscore, and Strikethrough. You can also change the font color as well as the background color.</p>
Pools	
Name	Displays the name of all the pools in the diagram.
Boundary Visible	Indicates whether or not the pool is visible on the diagram.
Edit Pools	Click  to open the <a href="#">Edit Pools</a> Property View.
Links	
Add Link	Opens the <a href="#">Create Link</a> wizard. This wizard allows you to create conceptual or usage links between elements.
Edit Link	Opens the property view for the selected link.
Delete Link	Deletes the selected link (either the link or the link target).
Show Selected Links on Active Diagram	Once you have created a link in the Diagram View, click this icon to display the links for the selected object in the diagram.
Expand All	Expands all the nodes in the tree.
Collapse All	Collapses all the nodes in the tree.
Refresh Links	Updates all the nodes in the Link Report.

Property View	Description
Usage (CRUD)	
Usage	<p>The header displays the name of the linked element and the status of the filter (on or off).</p> <p>Receivers: Displays a list of the elements with usages (receivers). You can select multiple receivers in this list and delete all the receivers that are selected.</p> <p>Usage: Displays the usage setting (C, R, U, D). You can change the Usage attributes in this column and this change is reflected in the diagram. For example, you can change a C (Create) type to a U (Update) type.</p> <p>Usage Description: Displays the information entered in the Description text field for the target object of the usage. For example, if a usage was drawn between a task and a Data Store object, the description of the Data Store object is displayed.</p> <p>If there are no links or all the links have been filtered out, you are given the information that "No usages have been defined for this element" in the Receivers column.</p>
<a href="#">Add Usage</a>	Opens the Create Usage wizard where you can create a new usage.
<a href="#">Edit Usage</a>	<p>When you select a Receiver in the table, the edit option becomes available. Click this to open the Usage edit tab where you can edit the name of the usage. The default name is "Usage". You can also change the usage settings (Create, Read, Update, and Delete).</p> 
Delete	<p>When you select a Receiver in the table, the delete option becomes available. This action removes the selected receiver from the usage.</p> 
Show Selected Usages	<p>When you select a Receiver in the table, the Show Selected Usages option () becomes available. Click this icon to display the usage for the selected receiver in the diagram, including the usage settings.</p>
Filter Receiver Types	Opens the Usage Report Filter dialog where you can select the types of objects you want included in the Usage Report.
<a href="#">Export Usage Report</a>	You can export the Usage (CRUD) reports in the following formats: CSV, HTML, PDF, and RTF
<a href="#">Print</a>	Opens the Print dialog where you can select a printer, set preferences, select a page range and number of copies and then print.
Refresh Usage	Updates all the nodes in the Usage Report.





Property View	Description
Impact Analysis	
Filter Designation	<p>Indicates whether a <a href="#">Filter</a> has been set for the Impact Analysis Report.</p> <p>Two icons are displayed to the left of the Filter Designation indicator:</p> <p> Click  to display the impact analysis information in a tree format.</p> <p> Click  to display the impact analysis information in a table format.</p>
<a href="#">Create Impact Analysis Diagram</a>	Once you create a link you can create a diagram that is a graphical representation of that link.
<a href="#">Filter</a>	Opens the Impact Analysis Filter dialog
Export	You can export and save the Impact Analysis report in the following file formats: CSV, HTML, PDF, and RTF.
Print	Opens the Print dialog where you can select a printer, set preferences, select a page range and number of copies and then print.
Expand All	Expands all the nodes in the tree.
Collapse All	Collapses all the nodes in the tree.
Refresh	Updates all the nodes in the Impact Analysis Report.



### Process ref properties





When you click edit  an additional tab opens where you can edit the properties for the selected diagram.

Property View	Description
General	
Name	Label that appears for an element both in the Model View tree and in the diagram. You can edit this label.
Categories	The modeler may add one or more defined Categories that can be used for purposes such as reporting and analysis.
Process Type	ProcessType is an attribute that provides information about which lower-level language the Pool will be mapped. By default, the ProcessType is None (or undefined).
Status	The Status of a Process is determined when the Process is being executed by a process engine. The Status of a Process can be used within Assignment Expressions.

Property View	Description
<a href="#">Ad hoc</a>	<p>Ad hoc is a boolean attribute, which has a default of False. This specifies whether the Embedded Sub-Process is Ad Hoc or not. The activities within an Ad Hoc Embedded Sub-Process are not controlled or sequenced in a particular order, there performance is determined by the performers of the activities.</p> <p><b>Note:</b> You can set this attribute for multiple subprocesses.</p>
Suppress Join Failure	<p>A join condition provides status about an incoming link. A join failure indicates that link execution failed. At the process level, this attribute specifies whether a join failure is suppressed for the whole process.</p>
Enable Instance Compensation	<p>This attribute is included for mapping to BPEL4WS. It specifies whether or not a compensation can be performed after the Process has completed normally.</p>
Description	
	<p>A text box where you can enter information describing or defining the project. Right-click text to open a shortcut menu. You can cut, copy, paste, and delete selected text within the Description text box. You can paste plain text from external applications.</p> <p>You can undo any action and you can select all text by pressing Ctrl+A.</p> <p>The following formatting options are available for the text: Bold, Italics, Underscore, and Strikethrough. You can also change the font color as well as the background color.</p>
Notes	
	<p>A text box where you can annotate the element with additional information. Right-click text to open a shortcut menu. You can cut, copy, paste, and delete selected text within the Notes text box. You can paste plain text from external applications.</p> <p>You can undo any action and you can select all text by pressing Ctrl+A.</p> <p>The following formatting options are available for the text: Bold, Italics, Underscore, and Strikethrough. You can also change the font color as well as the background color.</p>
Assignments	
Name	<p>Label that appears for an element both in the Model View tree and in the diagram. You can edit this label.</p>
To	<p>The target for the Assignment must be a Property of the Process or the activity itself.</p>

Property View	Description
From	The Expression must be made up of a combination of Values, Properties, and Attributes, which are separated by operators such as add or multiply. The expression language is defined in the ExpressionLanguage attribute of the Business Process Diagram.
Assign Time	<p>An Assignment may have a AssignTime setting. If the Object is an activity (Task, Sub-Process, or Process), then the Assignment must have an AssignTime. A value of Start means that the assignment shall occur at the start of the activity. This can be used to assign the higher-level (global) Properties of the Process to the (local) Properties of the activity as an input to the activity.</p> <p>A value of End means that the assignment shall occur at the end of the activity. This can be used to assign the (local) Properties of the activity to the higher-level (global) Properties of the Process as an output to the activity.</p>
Create Assignment	Click  to create a new assignment for the element.
<a href="#">Edit Assignment</a>	When you click edit  an additional tab opens where you can edit the selected assignments.
Delete Assignment	Deletes the selected assignment.
Properties	
Name	Modeler-defined Properties may be added to an activity. These Properties are "local" to the activity and are only for use within the processing of the activity. The fully delineated name of these properties is "<process name>.<activity name>.<property name>". You can add, <a href="#">edit</a> and delete these properties.
Type	Each Property has a Type (for example, type="String"). A Property may be of type Set, which allows child Properties.
Correlation	If the ConditionType attribute is set to Expression, then the ConditionExpression attribute must be defined. Otherwise, it is not valid. This attribute is included for mapping to BPEL4WS. The Property will map to a <i>correlationSet</i> and the child Properties will be <i>properties</i> of that <i>correlationSet</i> .
Links	
Add Link	Opens the <a href="#">Create Link</a> wizard. This wizard allows you to create conceptual or usage links between elements.
Edit Link	Opens the property view for the selected link.
Delete Link	Deletes the selected link (either the link or the link target).
Show Selected Links on Active Diagram	Once you have created a link in the Diagram View, click this icon to display the links for the selected object in the diagram.
Expand All	Expands all the nodes in the tree.
Collapse All	Collapses all the nodes in the tree.
Refresh Links	Updates all the nodes in the Link Report.

Property View	Description
Usage (CRUD)	
Usage	<p>The header displays the name of the linked element and the status of the filter (on or off).</p> <p><b>Receivers:</b> Displays a list of the elements with usages (receivers). You can select multiple receivers in this list and delete all the receivers that are selected.</p> <p><b>Usage:</b> Displays the usage setting (C, R, U, D). You can change the Usage attributes in this column and this change is reflected in the diagram. For example, you can change a C (Create) type to a U (Update) type.</p> <p><b>Usage Description:</b> Displays the information entered in the Description text field for the target object of the usage. For example, if a usage was drawn between a task and a Data Store object, the description of the Data Store object is displayed.</p> <p>If there are no links or all the links have been filtered out, you are given the information that "No usages have been defined for this element" in the Receivers column.</p>
<a href="#">Add Usage</a>	Opens the Create Usage wizard where you can create a new usage.
<a href="#">Edit Usage</a>	<p>When you select a Receiver in the table, the edit option becomes available. Click this to open the Usage edit tab where you can edit the name of the usage. The default name is "Usage". You can also change the usage settings (Create, Read, Update, and Delete).</p> 
Delete	<p>When you select a Receiver in the table, the delete option becomes available. This action removes the selected receiver from the usage.</p> 
Show Selected Usages	<p>When you select a Receiver in the table, the Show Selected Usages option () becomes available. Click this icon to display the usage for the selected receiver in the diagram, including the usage settings.</p>
Filter Receiver Types	Opens the Usage Report Filter dialog where you can select the types of objects you want included in the Usage Report.
<a href="#">Export Usage Report</a>	You can export the Usage (CRUD) reports in the following formats: CSV, HTML, PDF, and RTF
<a href="#">Print</a>	Opens the Print dialog where you can select a printer, set preferences, select a page range and number of copies and then print.
Refresh Usage	Updates all the nodes in the Usage Report.

Property View	Description
Impact Analysis	
Filter Designation	<p>Indicates whether a <a href="#">Filter</a> has been set for the Impact Analysis Report.</p> <p>Two icons are displayed to the left of the Filter Designation indicator:</p> <p> Click  to display the impact analysis information in a tree format.</p> <p> Click  to display the impact analysis information in a table format.</p>
<a href="#">Create Impact Analysis Diagram</a>	Once you create a link you can create a diagram that is a graphical representation of that link.
<a href="#">Filter</a>	Opens the Impact Analysis Filter dialog
Export	You can export and save the Impact Analysis report in the following file formats: CSV, HTML, PDF, and RTF.
Print	Opens the Print dialog where you can select a printer, set preferences, select a page range and number of copies and then print.
Expand All	Expands all the nodes in the tree.
Collapse All	Collapses all the nodes in the tree.
Refresh	Updates all the nodes in the Impact Analysis Report.

### Editing the properties

When you click edit  an additional tab opens where you can edit the selected Process.

Property View	Description
General	
Name	Label that appears for an element both in the Model View tree and in the diagram. You can edit this label.
Type	Each Property has a Type (for example, type="String"). A Property may be of type Set, which allows child Properties.

Property View	Description
Description	
	<p>A text box where you can enter information describing or defining the project. Right-click text to open a shortcut menu. You can cut, copy, paste, and delete selected text within the Description text box. You can paste plain text from external applications.</p> <p>You can undo any action and you can select all text by pressing Ctrl+A.</p> <p>The following formatting options are available for the text: Bold, Italics, Underscore, and Strikethrough. You can also change the font color as well as the background color.</p>
Notes	
	<p>A text box where you can annotate the element with additional information. Right-click text to open a shortcut menu. You can cut, copy, paste, and delete selected text within the Notes text box. You can paste plain text from external applications.</p> <p>You can undo any action and you can select all text by pressing Ctrl+A.</p> <p>The following formatting options are available for the text: Bold, Italics, Underscore, and Strikethrough. You can also change the font color as well as the background color.</p>

### Using the Ad hoc properties editor

The table below describes the properties for using the Ad hoc property:

Property View	Description
Ad hoc	
Ad hoc Ordering	<p>If the Embedded Sub-Process is Ad Hoc (the Ad hoc attribute is True), then the Ad hoc Ordering attribute must be included. This attribute defines if the activities within the Process can be performed in Parallel or must be performed sequentially. The default setting is Parallel and the setting of Sequential is a restriction on the performance that may be required due to shared resources.</p>
Ad hoc Complex Condition	<p>If the Embedded Sub-Process is Ad Hoc (the Ad hoc attribute is True), then a Completion Condition MUST be included, which defines the conditions when the Process will end. The Ad Hoc marker SHALL be placed at the bottom center of the Process or the Sub-Process shape for Ad Hoc Processes.</p>

## Using the Transaction properties editor

This option determines whether or not the behavior of the Sub-Process will follow the behavior of a Transaction.

Property View	Description
Transaction	Select this option if you want to designate this as a transaction.
Transaction ID	If the Transaction attribute is False, then a Transaction must not be identified. If the Transaction attribute is True, then a Transaction must be identified. Note that Transactions that are in different Pools and are connected through Message Flow must have the same TransactionID.
Transaction Protocol	This identifies the Protocol (e.g., WS-Transaction or BTP) that will be used to control the transactional behavior of the Sub-Process.
Transaction Method	Transaction Method is an attribute that defines the technique that will be used to undo a Transaction that has been cancelled. The default is Compensate, but the attribute may be set to Store or Image.



## Gateways







A Gateway controls the divergence and convergency of the Sequence Flow. It determines branching, forking, merging, and joining of paths. The table below describes the Property View fields available for a Gateway:

Property View	Description
General	
Name	Label that appears for an element both in the Model View tree and in the diagram. You can edit this label.
Categories	You can add one or more defined Categories that can be used for purposes such as reporting and analysis.
Type	The following <a href="#">Gateway Control Types</a> are available: None, Databased, EventBased, Inclusive, and Complex.
Incoming Condition	If there are Multiple incoming Sequence Flows, you must set an IncomingCondition expression. This consists of an expression that can reference Sequence Flow names and or Process Properties (Data).
Outgoing Condition	If there are Multiple outgoing Sequence Flows, you must set an OutgoingCondition expression. This consists of an expression that can reference (outgoing) Sequence Flow Ids and or ProcessProperties (Data).

Property View	Description
Description	
	<p>A text box where you can enter information describing or defining the project. Right-click text to open a shortcut menu. You can cut, copy, paste, and delete selected text within the Description text box. You can paste plain text from external applications.</p> <p>You can undo any action and you can select all text by pressing Ctrl+A.</p> <p>The following formatting options are available for the text: Bold, Italics, Underscore, and Strikethrough. You can also change the font color as well as the background color.</p>
Notes	
	<p>A text box where you can annotate the element with additional information. Right-click text to open a shortcut menu. You can cut, copy, paste, and delete selected text within the Notes text box. You can paste plain text from external applications.</p> <p>You can undo any action and you can select all text by pressing Ctrl+A.</p> <p>The following formatting options are available for the text: Bold, Italics, Underscore, and Strikethrough. You can also change the font color as well as the background color.</p>
Assignments	
Name	Label that appears for an element both in the Model View tree and in the diagram. You can edit this label.
To	The target for the Assignment must be a Property of the Process or the activity itself.
From	The Expression must be made up of a combination of Values, Properties, and Attributes, which are separated by operators such as add or multiply. The expression language is defined in the ExpressionLanguage attribute of the Business Process Diagram.
Assign Time	<p>An Assignment may have a AssignTime setting. If the Object is an activity (Task, Sub-Process, or Process), then the Assignment must have an AssignTime. A value of Start means that the assignment shall occur at the start of the activity. This can be used to assign the higher-level (global) Properties of the Process to the (local) Properties of the activity as an input to the activity.</p> <p>A value of End means that the assignment shall occur at the end of the activity. This can be used to assign the (local) Properties of the activity to the higher-level (global) Properties of the Process as an output to the activity.</p>



Property View	Description
Create Assignment	Click  to create a new assignment for the element.
<a href="#">Edit Assignment</a>	When you click edit  an additional tab opens where you can edit the selected assignments.
Delete Assignment	Deletes the selected assignment.
Gates	
Name	Each Gate will map to a <i>case</i> of the <i>switch</i> . The <i>cases</i> will be listed in the <i>switch</i> in the same order as they are listed for the Gateway. You can add, <a href="#">edit</a> these gates.
Sequence Flow	This will map to the <i>condition</i> for a <i>switch</i> case. Lists the name of the outgoing sequence flow.
Default	This will map to the <i>otherwise</i> element of the <i>switch</i> .
Links	
Add Link	Opens the <a href="#">Create Link</a> wizard. This wizard allows you to create conceptual or usage links between elements.
Edit Link	Opens the property view for the selected link.
Delete Link	Deletes the selected link (either the link or the link target).
Show Selected Links on Active Diagram	Once you have created a link in the Diagram View, click this icon to display the links for the selected object in the diagram.
Expand All	Expands all the nodes in the tree.
Collapse All	Collapses all the nodes in the tree.
Refresh Links	Updates all the nodes in the Link Report.
Usage (CRUD)	
Usage	<p>The header displays the name of the linked element and the status of the filter (on or off).</p> <p><b>Receivers:</b> Displays a list of the elements with usages (receivers). You can select multiple receivers in this list and delete all the receivers that are selected.</p> <p><b>Usage:</b> Displays the usage setting (C, R, U, D). You can change the Usage attributes in this column and this change is reflected in the diagram. For example, you can change a C (Create) type to a U (Update) type.</p> <p><b>Usage Description:</b> Displays the information entered in the Description text field for the target object of the usage. For example, if a usage was drawn between a task and a Data Store object, the description of the Data Store object is displayed.</p> <p>If there are no links or all the links have been filtered out, you are given the information that "No usages have been defined for this element" in the Receivers column.</p>
<a href="#">Add Usage</a>	Opens the Create Usage wizard where you can create a new usage.

Property View	Description
<a href="#">Edit Usage</a>	When you select a Receiver in the table, the edit option becomes available. Click this to open the Usage edit tab where you can edit the name of the usage. The default name is "Usage". You can also change the usage settings (Create, Read, Update, and Delete). 
Delete	When you select a Receiver in the table, the delete option becomes available. This action removes the selected receiver from the usage. 
Show Selected Usages	When you select a Receiver in the table, the Show Selected Usages option (  ) becomes available. Click this icon to display the usage for the selected receiver in the diagram, including the usage settings.
Filter Receiver Types	Opens the Usage Report Filter dialog where you can select the types of objects you want included in the Usage Report.
<a href="#">Export Usage Report</a>	You can export the Usage (CRUD) reports in the following formats: CSV, HTML, PDF, and RTF
<a href="#">Print</a>	Opens the Print dialog where you can select a printer, set preferences, select a page range and number of copies and then print.
Refresh Usage	Updates all the nodes in the Usage Report.
Impact Analysis	
Filter Designation	Indicates whether a <a href="#">Filter</a> has been set for the Impact Analysis Report. Two icons are displayed to the left of the Filter Designation indicator:  Click  to display the impact analysis information in a tree format.  Click  to display the impact analysis information in a table format.
<a href="#">Create Impact Analysis Diagram</a>	Once you create a link you can create a diagram that is a graphical representation of that link.
<a href="#">Filter</a>	Opens the Impact Analysis Filter dialog
Export	You can export and save the Impact Analysis report in the following file formats: CSV, HTML, PDF, and RTF.
Print	Opens the Print dialog where you can select a printer, set preferences, select a page range and number of copies and then print.
Expand All	Expands all the nodes in the tree.
Collapse All	Collapses all the nodes in the tree.
Refresh	Updates all the nodes in the Impact Analysis Report.
Appearance	
<a href="#">Font and Color Options</a>	Use these commands to change fonts and element colors.



Property View	Description
<a href="#">Rendering</a>	Use these commands to change the shadowing and gradient settings for an element.
<a href="#">Horizontal Alignment</a>	Use these commands to set the justification for text labels in an element.
Diagram Display Options	Select this option to show the element label.
Line Display Options	Select the width of the border from the drop-down list. You can select from 1 to 5 pixels.
Apply to Diagram	Applies the formatting changes to all existing gateways on the active diagram.
Restore Defaults	Restores the default settings for all changes made in the Appearance tab.
Set as Default	All formatting changes made in the Appearance tab become the default settings for new gateways placed in the Diagram View.





### Editing assignments

When you click edit  , an additional tab opens where you can edit the selected assignments.

Property View	Description
General	
Name	Label that appears for an element both in the Model View tree and in the diagram. You can edit this label.
To	The target for the Assignment must be a Property of the Process or the activity itself.
From	The Expression must be made up of a combination of Values, Properties, and Attributes, which are separated by operators such as add or multiply.
Assign Time	An Assignment may have an AssignTime setting. If the Object is an activity (Task, Sub-Process, or Process), then the Assignment must have an AssignTime. A value of Start means that the assignment shall occur at the start of the activity. This can be used to assign the higher-level (global) Properties of the Process to the (local) Properties of the activity as an input to the activity.

Property View	Description
Description	
	<p>A text box where you can enter information describing or defining the project. Right-click text to open a shortcut menu. You can cut, copy, paste, and delete selected text within the Description text box. You can paste plain text from external applications.</p> <p>You can undo any action and you can select all text by pressing Ctrl+A.</p> <p>The following formatting options are available for the text: Bold, Italics, Underscore, and Strikethrough. You can also change the font color as well as the background color.</p>
Notes	
	<p>A text box where you can annotate the element with additional information. Right-click text to open a shortcut menu. You can cut, copy, paste, and delete selected text within the Notes text box. You can paste plain text from external applications.</p> <p>You can undo any action and you can select all text by pressing Ctrl+A.</p> <p>The following formatting options are available for the text: Bold, Italics, Underscore, and Strikethrough. You can also change the font color as well as the background color.</p>
Links	
Add Link	Opens the <a href="#">Create Link</a> wizard. This wizard allows you to create conceptual or usage links between elements.
Edit Link	Opens the property view for the selected link.
Delete Link	Deletes the selected link (either the link or the link target).
Show Selected Links on Active Diagram	Once you have created a link in the Diagram View, click this icon to display the links for the selected object in the diagram.
Expand All	Expands all the nodes in the tree.
Collapse All	Collapses all the nodes in the tree.
Refresh Links	Updates all the nodes in the Link Report.

Property View	Description
Usage (CRUD)	
Usage	<p>The header displays the name of the linked element and the status of the filter (on or off).</p> <p>Receivers: Displays a list of the elements with usages (receivers). You can select multiple receivers in this list and delete all the receivers that are selected.</p> <p>Usage: Displays the usage setting (C, R, U, D). You can change the Usage attributes in this column and this change is reflected in the diagram. For example, you can change a C (Create) type to a U (Update) type.</p> <p>Usage Description: Displays the information entered in the Description text field for the target object of the usage. For example, if a usage was drawn between a task and a Data Store object, the description of the Data Store object is displayed.</p> <p>If there are no links or all the links have been filtered out, you are given the information that "No usages have been defined for this element" in the Receivers column.</p>
<a href="#">Add Usage</a>	Opens the Create Usage wizard where you can create a new usage.
<a href="#">Edit Usage</a>	<p>When you select a Receiver in the table, the edit option becomes available. Click this to open the Usage edit tab where you can edit the name of the usage. The default name is "Usage". You can also change the usage settings (Create, Read, Update, and Delete).</p> 
Delete	<p>When you select a Receiver in the table, the delete option becomes available. This action removes the selected receiver from the usage.</p> 
Show Selected Usages	<p>When you select a Receiver in the table, the Show Selected Usages option () becomes available. Click this icon to display the usage for the selected receiver in the diagram, including the usage settings.</p>
Filter Receiver Types	Opens the Usage Report Filter dialog where you can select the types of objects you want included in the Usage Report.
<a href="#">Export Usage Report</a>	You can export the Usage (CRUD) reports in the following formats: CSV, HTML, PDF, and RTF
<a href="#">Print</a>	Opens the Print dialog where you can select a printer, set preferences, select a page range and number of copies and then print.
Refresh Usage	Updates all the nodes in the Usage Report.





Property View	Description
Impact Analysis	
Filter Designation	<p>Indicates whether a <a href="#">Filter</a> has been set for the Impact Analysis Report.</p> <p>Two icons are displayed to the left of the Filter Designation indicator:</p> <p> Click  to display the impact analysis information in a tree format.</p> <p> Click  to display the impact analysis information in a table format.</p>
<a href="#">Create Impact Analysis Diagram</a>	Once you create a link you can create a diagram that is a graphical representation of that link.
<a href="#">Filter</a>	Opens the Impact Analysis Filter dialog
Export	You can export and save the Impact Analysis report in the following file formats: CSV, HTML, PDF, and RTF.
Print	Opens the Print dialog where you can select a printer, set preferences, select a page range and number of copies and then print.
Expand All	Expands all the nodes in the tree.
Collapse All	Collapses all the nodes in the tree.
Refresh	Updates all the nodes in the Impact Analysis Report.

### Editing gates





When you click edit  an additional tab opens where you can edit the selected gates.

Property View	Description
General	
Name	Label that appears for an element both in the Model View tree and in the diagram. You can edit this label.
Outgoing Sequence Flow	Displays the destination of the outgoing sequence flow. Click <a href="#">edit</a> to change/view the properties for that sequence flow.

Property View	Description
Description	
	<p>A text box where you can enter information describing or defining the project. Right-click text to open a shortcut menu. You can cut, copy, paste, and delete selected text within the Description text box. You can paste plain text from external applications.</p> <p>You can undo any action and you can select all text by pressing Ctrl+A.</p> <p>The following formatting options are available for the text: Bold, Italics, Underscore, and Strikethrough. You can also change the font color as well as the background color.</p>
Notes	
	<p>A text box where you can annotate the element with additional information. Right-click text to open a shortcut menu. You can cut, copy, paste, and delete selected text within the Notes text box. You can paste plain text from external applications.</p> <p>You can undo any action and you can select all text by pressing Ctrl+A.</p> <p>The following formatting options are available for the text: Bold, Italics, Underscore, and Strikethrough. You can also change the font color as well as the background color.</p>
Assignments	
Name	Label that appears for an element both in the Model View tree and in the diagram. You can edit this label.
To	The target for the Assignment must be a Property of the Process or the activity itself.
From	The Expression must be made up of a combination of Values, Properties, and Attributes, which are separated by operators such as add or multiply. The expression language is defined in the ExpressionLanguage attribute of the Business Process Diagram.
Assign Time	<p>An Assignment may have a AssignTime setting. If the Object is an activity (Task, Sub-Process, or Process), then the Assignment must have an AssignTime. A value of Start means that the assignment shall occur at the start of the activity. This can be used to assign the higher-level (global) Properties of the Process to the (local) Properties of the activity as an input to the activity.</p> <p>A value of End means that the assignment shall occur at the end of the activity. This can be used to assign the (local) Properties of the activity to the higher-level (global) Properties of the Process as an output to the activity.</p>

Property View	Description
Create Assignment	Click  to create a new assignment for the element.
<a href="#">Edit Assignment</a>	When you click edit  an additional tab opens where you can edit the selected assignments.
Delete Assignment	Deletes the selected assignment.
Links	
Add Link	Opens the <a href="#">Create Link</a> wizard. This wizard allows you to create conceptual or usage links between elements.
Edit Link	Opens the property view for the selected link.
Delete Link	Deletes the selected link (either the link or the link target).
Show Selected Links on Active Diagram	Once you have created a link in the Diagram View, click this icon to display the links for the selected object in the diagram.
Expand All	Expands all the nodes in the tree.
Collapse All	Collapses all the nodes in the tree.
Refresh Links	Updates all the nodes in the Link Report.
Usage (CRUD)	
Usage	<p>The header displays the name of the linked element and the status of the filter (on or off).</p> <p>Receivers: Displays a list of the elements with usages (receivers). You can select multiple receivers in this list and delete all the receivers that are selected.</p> <p>Usage: Displays the usage setting (C, R, U, D). You can change the Usage attributes in this column and this change is reflected in the diagram. For example, you can change a C (Create) type to a U (Update) type.</p> <p>Usage Description: Displays the information entered in the Description text field for the target object of the usage. For example, if a usage was drawn between a task and a Data Store object, the description of the Data Store object is displayed.</p> <p>If there are no links or all the links have been filtered out, you are given the information that "No usages have been defined for this element" in the Receivers column.</p>
<a href="#">Add Usage</a>	Opens the Create Usage wizard where you can create a new usage.
<a href="#">Edit Usage</a>	When you select a Receiver in the table, the edit option becomes available. Click this to open the Usage edit tab where you can edit the name of the usage. The default name is "Usage". You can also change the usage settings (Create, Read, Update, and Delete). 
Delete	When you select a Receiver in the table, the delete option becomes available. This action removes the selected receiver from the usage. 



Property View	Description
Show Selected Usages	When you select a Receiver in the table, the Show Selected Usages option (  ) becomes available. Click this icon to display the usage for the selected receiver in the diagram, including the usage settings.
Filter Receiver Types	Opens the Usage Report Filter dialog where you can select the types of objects you want included in the Usage Report.
<a href="#">Export Usage Report</a>	You can export the Usage (CRUD) reports in the following formats: CSV, HTML, PDF, and RTF
<a href="#">Print</a>	Opens the Print dialog where you can select a printer, set preferences, select a page range and number of copies and then print.
Refresh Usage	Updates all the nodes in the Usage Report.
Impact Analysis	
Filter Designation	Indicates whether a <a href="#">Filter</a> has been set for the Impact Analysis Report. Two icons are displayed to the left of the Filter Designation indicator:   Click  to display the impact analysis information in a tree format.   Click  to display the impact analysis information in a table format.
<a href="#">Create Impact Analysis Diagram</a>	Once you create a link you can create a diagram that is a graphical representation of that link.
<a href="#">Filter</a>	Opens the Impact Analysis Filter dialog
Export	You can export and save the Impact Analysis report in the following file formats: CSV, HTML, PDF, and RTF.
Print	Opens the Print dialog where you can select a printer, set preferences, select a page range and number of copies and then print.
Expand All	Expands all the nodes in the tree.
Collapse All	Collapses all the nodes in the tree.
Refresh	Updates all the nodes in the Impact Analysis Report.

## Connecting objects







There are three ways of connecting Events and Activities to each other or to other information [Sequence Flow](#); [Message Flow](#), and [Association](#).

## Sequence flow

The table below describes the Property View fields available for a Sequence Flow:

Property View	Description
General	
Name	Label that appears for an element both in the Model View tree and in the diagram. You can edit this label.
Categories	You can add one or more defined Categories that can be used for purposes such as reporting and analysis.
Source	Displays the source element for the sequence flow.
Target	Displays the name of the element where the sequence flow terminates.
Condition Type	<p>None: The default setting</p> <p>Expression: If the ConditionType attribute is set to Expression, then a condition marker shall be added to the line if the Sequence Flow is outgoing from an activity. However, a condition indicator <b>MUST NOT</b> be added to the line if the Sequence Flow is outgoing from a Gateway.</p> <p>Default: The ConditionType attribute may be set to Default only if the Source of the Sequence Flow is an activity or an Exclusive Data-Based Gateway. If the ConditionType is Default, then the Default marker <b>SHALL</b> be displayed.</p>
Condition Expression	If the ConditionType attribute is set to Expression, then the ConditionExpression attribute must be defined as a valid expression. The expression will be evaluated at runtime. If the result of the evaluation is True, then a Token is generated and will traverse the Sequence--Subject to any constraints imposed by a Source that is a Gateway.
Quantity	This attribute defines the number of Tokens that will be generated down the Sequence Flow. The default value is 1. The value <b>MUST NOT</b> be less than 1. This attribute defines the number of Tokens that will be generated down the Sequence Flow.
Description	
	<p>A text box where you can enter information describing or defining the project. Right-click text to open a shortcut menu. You can cut, copy, paste, and delete selected text within the Description text box. You can paste plain text from external applications.</p> <p>You can undo any action and you can select all text by pressing Ctrl+A.</p> <p>The following formatting options are available for the text: Bold, Italics, Underscore, and Strikethrough. You can also change the font color as well as the background color.</p>

Property View	Description
Notes	
	<p>A text box where you can annotate the element with additional information. Right-click text to open a shortcut menu. You can cut, copy, paste, and delete selected text within the Notes text box. You can paste plain text from external applications.</p> <p>You can undo any action and you can select all text by pressing Ctrl+A.</p> <p>The following formatting options are available for the text: Bold, Italics, Underscore, and Strikethrough. You can also change the font color as well as the background color</p>
Links	
Add Link	Opens the <a href="#">Create Link</a> wizard. This wizard allows you to create conceptual or usage links between elements.
Edit Link	Opens the property view for the selected link.
Delete Link	Deletes the selected link (either the link or the link target).
Show Selected Links on Active Diagram	Once you have created a link in the Diagram View, click this icon to display the links for the selected object in the diagram.
Expand All	Expands all the nodes in the tree.
Collapse All	Collapses all the nodes in the tree.
Refresh Links	Updates all the nodes in the Link Report.
Usage (CRUD)	
Usage	<p>The header displays the name of the linked element and the status of the filter (on or off).</p> <p>Receivers: Displays a list of the elements with usages (receivers). You can select multiple receivers in this list and delete all the receivers that are selected.</p> <p>Usage: Displays the usage setting (C, R, U, D). You can change the Usage attributes in this column and this change is reflected in the diagram. For example, you can change a C (Create) type to a U (Update) type.</p> <p>Usage Description: Displays the information entered in the Description text field for the target object of the usage. For example, if a usage was drawn between a task and a Data Store object, the description of the Data Store object is displayed.</p> <p>If there are no links or all the links have been filtered out, you are given the information that "No usages have been defined for this element" in the Receivers column.</p>
<a href="#">Add Usage</a>	Opens the Create Usage wizard where you can create a new usage.
<a href="#">Edit Usage</a>	<p>When you select a Receiver in the table, the edit option becomes available. Click this to open the Usage edit tab where you can edit the name of the usage. The default name is "Usage". You can also change the usage settings (Create, Read, Update, and Delete).</p> 

Property View	Description
Delete	When you select a Receiver in the table, the delete option becomes available. This action removes the selected receiver from the usage. 
Show Selected Usages	When you select a Receiver in the table, the Show Selected Usages option (  ) becomes available. Click this icon to display the usage for the selected receiver in the diagram, including the usage settings.
Filter Receiver Types	Opens the Usage Report Filter dialog where you can select the types of objects you want included in the Usage Report.
<a href="#">Export Usage Report</a>	You can export the Usage (CRUD) reports in the following formats: CSV, HTML, PDF, and RTF
<a href="#">Print</a>	Opens the Print dialog where you can select a printer, set preferences, select a page range and number of copies and then print.
Refresh Usage	Updates all the nodes in the Usage Report.
Impact Analysis	
Filter Designation	Indicates whether a <a href="#">Filter</a> has been set for the Impact Analysis Report. Two icons are displayed to the left of the Filter Designation indicator:  Click  to display the impact analysis information in a tree format.  Click  to display the impact analysis information in a table format.
<a href="#">Create Impact Analysis Diagram</a>	Once you create a link you can create a diagram that is a graphical representation of that link.
<a href="#">Filter</a>	Opens the Impact Analysis Filter dialog
Export	You can export and save the Impact Analysis report in the following file formats: CSV, HTML, PDF, and RTF.
Print	Opens the Print dialog where you can select a printer, set preferences, select a page range and number of copies and then print.
Expand All	Expands all the nodes in the tree.
Collapse All	Collapses all the nodes in the tree.
Refresh	Updates all the nodes in the Impact Analysis Report.
Appearance	
<a href="#">Font and Color Options</a>	Use these commands to change fonts and element colors. Note that the element fill command is unavailable for the Sequence Flow.
Diagram Display Options	Show Name: Select this option to show the element label. Show Connection: Select this option to display the line in the diagram.



Property View	Description
Line Display Options	<p>Layout: You can select one of three layout styles: curved, elbowed, or straight. The default is curved.</p> <p>Line Width: Select the width of the border from the drop-down list. You can select from 1 to 5 pixels.</p> <p>Source Decorator Size: Set the size of the decorator (arrow) at the origination point of the sequence flow. Your choices are: extra small (XS), small (S), medium (M), large (L), and extra large (XL).</p> <p>Target Decorator Size: Set the size of the decorator (arrow) at the termination point of the sequence flow. Your choices are: extra small (XS), small (S), medium (M), large (L), and extra large (XL).</p>
Apply to Diagram	Applies the formatting changes to all existing sequence flows on the active diagram.
Restore Defaults	Restores the default settings for all changes made in the Appearance tab.
Set as Default	All formatting changes made in the Appearance tab become the default settings for new sequence flows placed in the Diagram View.





## Message flow

The table below describes the Property View fields available for a Message Flow:

Property View	Description
General	
Name	Label that appears for an element both in the Model View tree and in the diagram. You can edit this label.
Categories	You can add one or more defined Categories that can be used for purposes such as reporting and analysis.
Message	Enter the text defining the message flow. Click  to open an additional view where you can edit <a href="#">properties</a> for the message.
Source	Displays the source element for the message flow.
Target	Displays the name of the element where the message flow terminates.

Property View	Description
Description	
	<p>A text box where you can enter information describing or defining the project. Right-click text to open a shortcut menu. You can cut, copy, paste, and delete selected text within the Description text box. You can paste plain text from external applications.</p> <p>You can undo any action and you can select all text by pressing Ctrl+A.</p> <p>The following formatting options are available for the text: Bold, Italics, Underscore, and Strikethrough. You can also change the font color as well as the background color.</p>
Notes	
	<p>A text box where you can annotate the element with additional information. Right-click text to open a shortcut menu. You can cut, copy, paste, and delete selected text within the Notes text box. You can paste plain text from external applications.</p> <p>You can undo any action and you can select all text by pressing Ctrl+A.</p> <p>The following formatting options are available for the text: Bold, Italics, Underscore, and Strikethrough. You can also change the font color as well as the background color.</p>
Links	
Add Link	Opens the <a href="#">Create Link</a> wizard. This wizard allows you to create conceptual or usage links between elements.
Edit Link	Opens the property view for the selected link.
Delete Link	Deletes the selected link (either the link or the link target).
Show Selected Links on Active Diagram	Once you have created a link in the Diagram View, click this icon to display the links for the selected object in the diagram.
Expand All	Expands all the nodes in the tree.
Collapse All	Collapses all the nodes in the tree.
Refresh Links	Updates all the nodes in the Link Report.

Property View	Description
Usage (CRUD)	
Usage	<p>The header displays the name of the linked element and the status of the filter (on or off).</p> <p>Receivers: Displays a list of the elements with usages (receivers). You can select multiple receivers in this list and delete all the receivers that are selected.</p> <p>Usage: Displays the usage setting (C, R, U, D). You can change the Usage attributes in this column and this change is reflected in the diagram. For example, you can change a C (Create) type to a U (Update) type.</p> <p>Usage Description: Displays the information entered in the Description text field for the target object of the usage. For example, if a usage was drawn between a task and a Data Store object, the description of the Data Store object is displayed.</p> <p>If there are no links or all the links have been filtered out, you are given the information that "No usages have been defined for this element" in the Receivers column.</p>
<a href="#">Add Usage</a>	Opens the Create Usage wizard where you can create a new usage.
<a href="#">Edit Usage</a>	<p>When you select a Receiver in the table, the edit option becomes available. Click this to open the Usage edit tab where you can edit the name of the usage. The default name is "Usage". You can also change the usage settings (Create, Read, Update, and Delete).</p> 
Delete	<p>When you select a Receiver in the table, the delete option becomes available. This action removes the selected receiver from the usage.</p> 
Show Selected Usages	<p>When you select a Receiver in the table, the Show Selected Usages option () becomes available. Click this icon to display the usage for the selected receiver in the diagram, including the usage settings.</p>
Filter Receiver Types	Opens the Usage Report Filter dialog where you can select the types of objects you want included in the Usage Report.
<a href="#">Export Usage Report</a>	You can export the Usage (CRUD) reports in the following formats: CSV, HTML, PDF, and RTF
<a href="#">Print</a>	Opens the Print dialog where you can select a printer, set preferences, select a page range and number of copies and then print.
Refresh Usage	Updates all the nodes in the Usage Report.



Property View	Description
Impact Analysis	
Filter Designation	<p>Indicates whether a <a href="#">Filter</a> has been set for the Impact Analysis Report.</p> <p>Two icons are displayed to the left of the Filter Designation indicator:</p> <p> Click  to display the impact analysis information in a tree format.</p> <p> Click  to display the impact analysis information in a table format.</p>
<a href="#">Create Impact Analysis Diagram</a>	Once you create a link you can create a diagram that is a graphical representation of that link.
<a href="#">Filter</a>	Opens the Impact Analysis Filter dialog
Export	You can export and save the Impact Analysis report in the following file formats: CSV, HTML, PDF, and RTF.
Print	Opens the Print dialog where you can select a printer, set preferences, select a page range and number of copies and then print.
Expand All	Expands all the nodes in the tree.
Collapse All	Collapses all the nodes in the tree.
Refresh	Updates all the nodes in the Impact Analysis Report.
Appearance	
<a href="#">Font and Color Options</a>	Use these commands to change fonts and element colors. Note that the element fill command is unavailable for the Message Flow.
Diagram Display Options	<p>Show Name: Select this option to show the element label.</p> <p>Show Connection: Select this option to display the line in the diagram.</p>
Line Display Options	<p>Layout: You can select one of three layout styles: curved, elbowed, or straight. The default is curved.</p> <p>Line Width: Select the width of the border from the drop-down list. You can select from 1 to 5 pixels.</p> <p>Source Decorator Size: Set the size of the decorator (arrow) at the origination point of the sequence flow. Your choices are: extra small (XS), small (S), medium (M), large (L), and extra large (XL).</p> <p>Target Decorator Size: Set the size of the decorator (arrow) at the termination point of the sequence flow. Your choices are: extra small (XS), small (S), medium (M), large (L), and extra large (XL).</p>
Apply to Diagram	Applies the formatting changes to all existing message flows on the active diagram.
Restore Defaults	Restores the default settings for all changes made in the Appearance tab.







Property View	Description
Set as Default	All formatting changes made in the Appearance tab become the default settings for new message flows placed in the Diagram View.

### Message Properties

The table below describes the Property View fields available for a Message Properties

Property View	Description
General	
Name	Label that appears for an element both in the Model View tree and in the diagram. You can edit this label.
From Participant	Enter the text defining the From Participant. Click  to open an additional view where you can edit <a href="#">properties</a> for this entry
To Participant	Enter the text defining the To Participant. Click  to open an additional view where you can edit <a href="#">properties</a> for this entry.
Description	
	<p>A text box where you can enter information describing or defining the project. Right-click text to open a shortcut menu. You can cut, copy, paste, and delete selected text within the Description text box. You can paste plain text from external applications.</p> <p>You can undo any action and you can select all text by pressing Ctrl+A.</p> <p>The following formatting options are available for the text: Bold, Italics, Underscore, and Strikethrough. You can also change the font color as well as the background color.</p>
Notes	
	<p>A text box where you can annotate the element with additional information. Right-click text to open a shortcut menu. You can cut, copy, paste, and delete selected text within the Notes text box. You can paste plain text from external applications.</p> <p>You can undo any action and you can select all text by pressing Ctrl+A.</p> <p>The following formatting options are available for the text: Bold, Italics, Underscore, and Strikethrough. You can also change the font color as well as the background color</p>
Properties	
Name	Label that appears for an element both in the Model View tree and in the diagram. You can edit this label.

Property View	Description
Type	Each Property has a Type (e.g., type="String"). A Property may be of type Set, which allows child Properties.
Correlation	If the ConditionType attribute is set to Expression, then the ConditionExpression attribute MUST be defined. Otherwise, it is not valid. This attribute is included for mapping to BPEL4WS. The Property will map to a <i>correlationSet</i> and the child Properties will be <i>properties</i> of that <i>correlationSet</i> .
Links	
Add Link	Opens the <a href="#">Create Link</a> wizard. This wizard allows you to create conceptual or usage links between elements.
Edit Link	Opens the property view for the selected link.
Delete Link	Deletes the selected link (either the link or the link target).
Show Selected Links on Active Diagram	Once you have created a link in the Diagram View, click this icon to display the links for the selected object in the diagram.
Expand All	Expands all the nodes in the tree.
Collapse All	Collapses all the nodes in the tree.
Refresh Links	Updates all the nodes in the Link Report.
Usage (CRUD)	
Usage	<p>The header displays the name of the linked element and the status of the filter (on or off).</p> <p>Receivers: Displays a list of the elements with usages (receivers). You can select multiple receivers in this list and delete all the receivers that are selected.</p> <p>Usage: Displays the usage setting (C, R, U, D). You can change the Usage attributes in this column and this change is reflected in the diagram. For example, you can change a C (Create) type to a U (Update) type.</p> <p>Usage Description: Displays the information entered in the Description text field for the target object of the usage. For example, if a usage was drawn between a task and a Data Store object, the description of the Data Store object is displayed.</p> <p>If there are no links or all the links have been filtered out, you are given the information that "No usages have been defined for this element" in the Receivers column.</p>
<a href="#">Add Usage</a>	Opens the Create Usage wizard where you can create a new usage.
<a href="#">Edit Usage</a>	When you select a Receiver in the table, the edit option becomes available. Click this to open the Usage edit tab where you can edit the name of the usage. The default name is "Usage". You can also change the usage settings (Create, Read, Update, and Delete). 
Delete	When you select a Receiver in the table, the delete option becomes available. This action removes the selected receiver from the usage. 



Property View	Description
Show Selected Usages	When you select a Receiver in the table, the Show Selected Usages option (  ) becomes available. Click this icon to display the usage for the selected receiver in the diagram, including the usage settings.
Filter Receiver Types	Opens the Usage Report Filter dialog where you can select the types of objects you want included in the Usage Report.
<a href="#">Export Usage Report</a>	You can export the Usage (CRUD) reports in the following formats: CSV, HTML, PDF, and RTF
<a href="#">Print</a>	Opens the Print dialog where you can select a printer, set preferences, select a page range and number of copies and then print.
Refresh Usage	Updates all the nodes in the Usage Report.
Impact Analysis	
Filter Designation	Indicates whether a <a href="#">Filter</a> has been set for the Impact Analysis Report. Two icons are displayed to the left of the Filter Designation indicator:  <div style="display: flex; flex-direction: column; align-items: center;"> <div style="display: flex; align-items: center; margin-bottom: 10px;">  <span>Click</span> </div> <div style="display: flex; align-items: center;">  <span>Click</span> </div> </div> to display the impact analysis information in a tree format.  to display the impact analysis information in a table format.
<a href="#">Create Impact Analysis Diagram</a>	Once you create a link you can create a diagram that is a graphical representation of that link.
<a href="#">Filter</a>	Opens the Impact Analysis Filter dialog
Export	You can export and save the Impact Analysis report in the following file formats: CSV, HTML, PDF, and RTF.
Print	Opens the Print dialog where you can select a printer, set preferences, select a page range and number of copies and then print.
Expand All	Expands all the nodes in the tree.
Collapse All	Collapses all the nodes in the tree.
Refresh	Updates all the nodes in the Impact Analysis Report.





From Participant Properties

The table below describes the Property View fields available for the From Participant Properties

Property View	Description
General	
Name	Label that appears for an element both in the Model View tree and in the diagram. You can edit this label.
Participant type	Each Property has a Name (e.g., name="Customer Name").

Property View	Description
Role	If the ParticipantType = Role, then a Role MUST be identified.
Entity	If the ParticipantType = Entity, then an Entity must be identified.
Description	
	<p>A text box where you can enter information describing or defining the project. Right-click text to open a shortcut menu. You can cut, copy, paste, and delete selected text within the Description text box. You can paste plain text from external applications.</p> <p>You can undo any action and you can select all text by pressing Ctrl+A.</p> <p>The following formatting options are available for the text: Bold, Italics, Underscore, and Strikethrough. You can also change the font color as well as the background color.</p>
Notes	
	<p>A text box where you can annotate the element with additional information. Right-click text to open a shortcut menu. You can cut, copy, paste, and delete selected text within the Notes text box. You can paste plain text from external applications.</p> <p>You can undo any action and you can select all text by pressing Ctrl+A.</p> <p>The following formatting options are available for the text: Bold, Italics, Underscore, and Strikethrough. You can also change the font color as well as the background color.</p>
Links	
Add Link	Opens the <a href="#">Create Link</a> wizard. This wizard allows you to create conceptual or usage links between elements.
Edit Link	Opens the property view for the selected link.
Delete Link	Deletes the selected link (either the link or the link target).
Show Selected Links on Active Diagram	Once you have created a link in the Diagram View, click this icon to display the links for the selected object in the diagram.
Expand All	Expands all the nodes in the tree.
Collapse All	Collapses all the nodes in the tree.
Refresh Links	Updates all the nodes in the Link Report.

Property View	Description
Usage (CRUD)	
Usage	<p>The header displays the name of the linked element and the status of the filter (on or off).</p> <p>Receivers: Displays a list of the elements with usages (receivers). You can select multiple receivers in this list and delete all the receivers that are selected.</p> <p>Usage: Displays the usage setting (C, R, U, D). You can change the Usage attributes in this column and this change is reflected in the diagram. For example, you can change a C (Create) type to a U (Update) type.</p> <p>Usage Description: Displays the information entered in the Description text field for the target object of the usage. For example, if a usage was drawn between a task and a Data Store object, the description of the Data Store object is displayed.</p> <p>If there are no links or all the links have been filtered out, you are given the information that "No usages have been defined for this element" in the Receivers column.</p>
<a href="#">Add Usage</a>	Opens the Create Usage wizard where you can create a new usage.
<a href="#">Edit Usage</a>	<p>When you select a Receiver in the table, the edit option becomes available. Click this to open the Usage edit tab where you can edit the name of the usage. The default name is "Usage". You can also change the usage settings (Create, Read, Update, and Delete).</p> 
Delete	<p>When you select a Receiver in the table, the delete option becomes available. This action removes the selected receiver from the usage.</p> 
Show Selected Usages	<p>When you select a Receiver in the table, the Show Selected Usages option () becomes available. Click this icon to display the usage for the selected receiver in the diagram, including the usage settings.</p>
Filter Receiver Types	Opens the Usage Report Filter dialog where you can select the types of objects you want included in the Usage Report.
<a href="#">Export Usage Report</a>	You can export the Usage (CRUD) reports in the following formats: CSV, HTML, PDF, and RTF
<a href="#">Print</a>	Opens the Print dialog where you can select a printer, set preferences, select a page range and number of copies and then print.
Refresh Usage	Updates all the nodes in the Usage Report.



Property View	Description
Impact Analysis	
Filter Designation	<p>Indicates whether a <a href="#">Filter</a> has been set for the Impact Analysis Report.</p> <p>Two icons are displayed to the left of the Filter Designation indicator:</p> <p> Click  to display the impact analysis information in a tree format.</p> <p> Click  to display the impact analysis information in a table format.</p>
<a href="#">Create Impact Analysis Diagram</a>	Once you create a link you can create a diagram that is a graphical representation of that link.
<a href="#">Filter</a>	Opens the Impact Analysis Filter dialog
Export	You can export and save the Impact Analysis report in the following file formats: CSV, HTML, PDF, and RTF.
Print	Opens the Print dialog where you can select a printer, set preferences, select a page range and number of copies and then print.
Expand All	Expands all the nodes in the tree.
Collapse All	Collapses all the nodes in the tree.
Refresh	Updates all the nodes in the Impact Analysis Report.

### To Participant Properties





The table below describes the Property View fields available for the From Participant Properties

Property View	Description
General	
Name	Label that appears for an element both in the Model View tree and in the diagram. You can edit this label.
Participant type	Each Property has a Name (e.g., name="Customer Name").
Role	If the ParticipantType = Role, then a Role MUST be identified.
Entity	If the ParticipantType = Entity, then an Entity must be identified.

Property View	Description
Description	
	<p>A text box where you can enter information describing or defining the project. Right-click text to open a shortcut menu. You can cut, copy, paste, and delete selected text within the Description text box. You can paste plain text from external applications.</p> <p>You can undo any action and you can select all text by pressing Ctrl+A.</p> <p>The following formatting options are available for the text: Bold, Italics, Underscore, and Strikethrough. You can also change the font color as well as the background color.</p>
Notes	
	<p>A text box where you can annotate the element with additional information. Right-click text to open a shortcut menu. You can cut, copy, paste, and delete selected text within the Notes text box. You can paste plain text from external applications.</p> <p>You can undo any action and you can select all text by pressing Ctrl+A.</p> <p>The following formatting options are available for the text: Bold, Italics, Underscore, and Strikethrough. You can also change the font color as well as the background color.</p>
Links	
Add Link	Opens the <a href="#">Create Link</a> wizard. This wizard allows you to create conceptual or usage links between elements.
Edit Link	Opens the property view for the selected link.
Delete Link	Deletes the selected link (either the link or the link target).
Show Selected Links on Active Diagram	Once you have created a link in the Diagram View, click this icon to display the links for the selected object in the diagram.
Expand All	Expands all the nodes in the tree.
Collapse All	Collapses all the nodes in the tree.
Refresh Links	Updates all the nodes in the Link Report.

Property View	Description
Usage (CRUD)	
Usage	<p>The header displays the name of the linked element and the status of the filter (on or off).</p> <p>Receivers: Displays a list of the elements with usages (receivers). You can select multiple receivers in this list and delete all the receivers that are selected.</p> <p>Usage: Displays the usage setting (C, R, U, D). You can change the Usage attributes in this column and this change is reflected in the diagram. For example, you can change a C (Create) type to a U (Update) type.</p> <p>Usage Description: Displays the information entered in the Description text field for the target object of the usage. For example, if a usage was drawn between a task and a Data Store object, the description of the Data Store object is displayed.</p> <p>If there are no links or all the links have been filtered out, you are given the information that "No usages have been defined for this element" in the Receivers column.</p>
<a href="#">Add Usage</a>	Opens the Create Usage wizard where you can create a new usage.
<a href="#">Edit Usage</a>	<p>When you select a Receiver in the table, the edit option becomes available. Click this to open the Usage edit tab where you can edit the name of the usage. The default name is "Usage". You can also change the usage settings (Create, Read, Update, and Delete).</p> 
Delete	<p>When you select a Receiver in the table, the delete option becomes available. This action removes the selected receiver from the usage.</p> 
Show Selected Usages	<p>When you select a Receiver in the table, the Show Selected Usages option () becomes available. Click this icon to display the usage for the selected receiver in the diagram, including the usage settings.</p>
Filter Receiver Types	Opens the Usage Report Filter dialog where you can select the types of objects you want included in the Usage Report.
<a href="#">Export Usage Report</a>	You can export the Usage (CRUD) reports in the following formats: CSV, HTML, PDF, and RTF
<a href="#">Print</a>	Opens the Print dialog where you can select a printer, set preferences, select a page range and number of copies and then print.
Refresh Usage	Updates all the nodes in the Usage Report.





Property View	Description
Impact Analysis	
Filter Designation	<p>Indicates whether a <a href="#">Filter</a> has been set for the Impact Analysis Report.</p> <p>Two icons are displayed to the left of the Filter Designation indicator:</p> <p> Click  to display the impact analysis information in a tree format.</p> <p> Click  to display the impact analysis information in a table format.</p>
<a href="#">Create Impact Analysis Diagram</a>	Once you create a link you can create a diagram that is a graphical representation of that link.
<a href="#">Filter</a>	Opens the Impact Analysis Filter dialog
Export	You can export and save the Impact Analysis report in the following file formats: CSV, HTML, PDF, and RTF.
Print	Opens the Print dialog where you can select a printer, set preferences, select a page range and number of copies and then print.
Expand All	Expands all the nodes in the tree.
Collapse All	Collapses all the nodes in the tree.
Refresh	Updates all the nodes in the Impact Analysis Report.





## Association

The table below describes the Property View fields available for an Association

Property View	Description
General	
Name	Label that appears for an element both in the Model View tree and in the diagram. You can edit this label.
Categories	You can add one or more defined Categories that can be used for purposes such as reporting and analysis.
Direction	<p>Direction is an attribute that defines whether or not the Association shows any directionality with an arrowhead.</p> <p>None: No arrow appears on the link. This is the default setting.</p> <p>To: The arrowhead is at the target object.</p> <p>From: The arrowhead is at the source artifact.</p> <p>Both: Arrows are place at both ends of the link indicating bi-directional flow.</p>
Source:	Displays the source element for the Association.
Target	Displays the name of the element where the Association terminates.

Property View	Description
Description	
	<p>A text box where you can enter information describing or defining the project. Right-click text to open a shortcut menu. You can cut, copy, paste, and delete selected text within the Description text box. You can paste plain text from external applications.</p> <p>You can undo any action and you can select all text by pressing Ctrl+A.</p> <p>The following formatting options are available for the text: Bold, Italics, Underscore, and Strikethrough. You can also change the font color as well as the background color.</p>
Notes	
	<p>A text box where you can annotate the element with additional information. Right-click text to open a shortcut menu. You can cut, copy, paste, and delete selected text within the Notes text box. You can paste plain text from external applications.</p> <p>You can undo any action and you can select all text by pressing Ctrl+A.</p> <p>The following formatting options are available for the text: Bold, Italics, Underscore, and Strikethrough. You can also change the font color as well as the background color.</p>
Links	
Add Link	Opens the <a href="#">Create Link</a> wizard. This wizard allows you to create conceptual or usage links between elements.
Edit Link	Opens the property view for the selected link.
Delete Link	Deletes the selected link (either the link or the link target).
Show Selected Links on Active Diagram	Once you have created a link in the Diagram View, click this icon to display the links for the selected object in the diagram.
Expand All	Expands all the nodes in the tree.
Collapse All	Collapses all the nodes in the tree.
Refresh Links	Updates all the nodes in the Link Report.

Property View	Description
Usage (CRUD)	
Usage	<p>The header displays the name of the linked element and the status of the filter (on or off).</p> <p>Receivers: Displays a list of the elements with usages (receivers). You can select multiple receivers in this list and delete all the receivers that are selected.</p> <p>Usage: Displays the usage setting (C, R, U, D). You can change the Usage attributes in this column and this change is reflected in the diagram. For example, you can change a C (Create) type to a U (Update) type.</p> <p>Usage Description: Displays the information entered in the Description text field for the target object of the usage. For example, if a usage was drawn between a task and a Data Store object, the description of the Data Store object is displayed.</p> <p>If there are no links or all the links have been filtered out, you are given the information that "No usages have been defined for this element" in the Receivers column.</p>
<a href="#">Add Usage</a>	Opens the Create Usage wizard where you can create a new usage.
<a href="#">Edit Usage</a>	<p>When you select a Receiver in the table, the edit option becomes available. Click this to open the Usage edit tab where you can edit the name of the usage. The default name is "Usage". You can also change the usage settings (Create, Read, Update, and Delete).</p> 
Delete	<p>When you select a Receiver in the table, the delete option becomes available. This action removes the selected receiver from the usage.</p> 
Show Selected Usages	<p>When you select a Receiver in the table, the Show Selected Usages option () becomes available. Click this icon to display the usage for the selected receiver in the diagram, including the usage settings.</p>
Filter Receiver Types	Opens the Usage Report Filter dialog where you can select the types of objects you want included in the Usage Report.
<a href="#">Export Usage Report</a>	You can export the Usage (CRUD) reports in the following formats: CSV, HTML, PDF, and RTF
<a href="#">Print</a>	Opens the Print dialog where you can select a printer, set preferences, select a page range and number of copies and then print.
Refresh Usage	Updates all the nodes in the Usage Report.

Property View	Description
Impact Analysis	
Filter Designation	<p>Indicates whether a <a href="#">Filter</a> has been set for the Impact Analysis Report.</p> <p>Two icons are displayed to the left of the Filter Designation indicator:</p> <p> Click  to display the impact analysis information in a tree format.</p> <p> Click  to display the impact analysis information in a table format.</p>
<a href="#">Create Impact Analysis Diagram</a>	Once you create a link you can create a diagram that is a graphical representation of that link.
<a href="#">Filter</a>	Opens the Impact Analysis Filter dialog
Export	You can export and save the Impact Analysis report in the following file formats: CSV, HTML, PDF, and RTF.
Print	Opens the Print dialog where you can select a printer, set preferences, select a page range and number of copies and then print.
Expand All	Expands all the nodes in the tree.
Collapse All	Collapses all the nodes in the tree.
Refresh	Updates all the nodes in the Impact Analysis Report.
Appearance	
<a href="#">Font and Color Options</a>	Use these commands to change fonts and element colors. Note that the element fill command is unavailable for the Association.
Diagram Display Options	<p>Show Name: Select this option to show the element label.</p> <p>Show Connection: Select this option to display the line in the diagram.</p>
Line Display Options	<p>Layout: You can select one of three layout styles: curved, elbowed, or straight. The default is curved.</p> <p>Line Width: Select the width of the border from the drop-down list. You can select from 1 to 5 pixels.</p> <p>Source Decorator Size: Set the size of the decorator (arrow) at the origination point of the sequence flow. Your choices are: extra small (XS), small (S), medium (M), large (L), and extra large (XL).</p> <p>Target Decorator Size: Set the size of the decorator (arrow) at the termination point of the sequence flow. Your choices are: extra small (XS), small (S), medium (M), large (L), and extra large (XL).</p>
Apply to Diagram	Applies the formatting changes to all existing associations on the active diagram.
Restore Defaults	Restores the default settings for all changes made in the Appearance tab.

Property View	Description
Set as Default	All formatting changes made in the Appearance tab become the default settings for new associations placed in the Diagram View.



## Swimlanes



You can group primary modeling elements by using swimlanes which consist of pools and lanes. A Pool represents a participant in a process. It also acts as a graphical container for partitioning a set of activities from other Pools. The three main elements are: [Pool](#), [Lane](#), and [Nested Lane](#).



### Pool

The table below describes the Property View fields available for a Pool:

Property View	Description
General	
Name	Label that appears for an element both in the Model View tree and in the diagram. You can edit this label.
Categories	You can add one or more defined Categories that can be used for purposes such as reporting and analysis.
<a href="#">Participant</a>	You must define the Participant for a Pool. The Participant can be either a Role or an Entity. This defines the role that a particular Entity or Role the Pool will play in a Diagram that includes collaboration.
<a href="#">Process</a>	When you click  an additional property view opens displaying the Process properties for the selected diagram.
Boundary visible	This attribute defines if the rectangular boundary for the Pool is visible. Only one Pool in the Diagram may have the attribute set to False.
Linked steward or business unit	Click the drop-down arrow to display a list of available stewards and business units that can be linked to a pool.
Description	
	<p>A text box where you can enter information describing or defining the project. Right-click text to open a shortcut menu. You can cut, copy, paste, and delete selected text within the Description text box. You can paste plain text from external applications.</p> <p>You can undo any action and you can select all text by pressing Ctrl+A.</p> <p>The following formatting options are available for the text: Bold, Italics, Underscore, and Strikethrough. You can also change the font color as well as the background color.</p>

Property View	Description
Notes	
	<p>A text box where you can annotate the element with additional information. Right-click text to open a shortcut menu. You can cut, copy, paste, and delete selected text within the Notes text box. You can paste plain text from external applications.</p> <p>You can undo any action and you can select all text by pressing Ctrl+A.</p> <p>The following formatting options are available for the text: Bold, Italics, Underscore, and Strikethrough. You can also change the font color as well as the background color</p>
Lanes	
Name	<p>Displays the name of the lane(s) within the selected pool. You have the following functions available:</p> <p><b>Add:</b> Adds another lane to the pool. If you opened the Property View from the Model View, the new lane appears in the Model View tree. If you opened the Property View from the presentation element, the new lane appears both in the Model View tree and in the Diagram View.</p> <p><b>Edit:</b> Opens a Property View for the selected lane where you can make changes to the properties for that lane. Notice that the <a href="#">Appearance</a> tab is not available on this page.</p> <p><b>Delete:</b> Delete the selected lane from this Property View.</p>
Create Lane	Click  to create a new lane.
Edit Lane	Select a lane in the list box and click Edit (  ). The Lane property view for the selected lane opens.
Delete Lane	Delete a selected lane by clicking  . The lane is immediately deleted without a warning.
Move Lane Up	Move the selected lane up in the grid.
Move Lane Down	Move the selected lane down in the grid.
Links	
Add Link	Opens the <a href="#">Create Link</a> wizard. This wizard allows you to create conceptual or usage links between elements.
Edit Link	Opens the property view for the selected link.
Delete Link	Deletes the selected link (either the link or the link target).
Show Selected Links on Active Diagram	Once you have created a link in the Diagram View, click this icon to display the links for the selected object in the diagram.
Expand All	Expands all the nodes in the tree.
Collapse All	Collapses all the nodes in the tree.
Refresh Links	Updates all the nodes in the Link Report.

Property View	Description
Usage (CRUD)	
Usage	<p>The header displays the name of the linked element and the status of the filter (on or off).</p> <p>Receivers: Displays a list of the elements with usages (receivers). You can select multiple receivers in this list and delete all the receivers that are selected.</p> <p>Usage: Displays the usage setting (C, R, U, D). You can change the Usage attributes in this column and this change is reflected in the diagram. For example, you can change a C (Create) type to a U (Update) type.</p> <p>Usage Description: Displays the information entered in the Description text field for the target object of the usage. For example, if a usage was drawn between a task and a Data Store object, the description of the Data Store object is displayed.</p> <p>If there are no links or all the links have been filtered out, you are given the information that "No usages have been defined for this element" in the Receivers column.</p>
<a href="#">Add Usage</a>	Opens the Create Usage wizard where you can create a new usage.
<a href="#">Edit Usage</a>	<p>When you select a Receiver in the table, the edit option becomes available. Click this to open the Usage edit tab where you can edit the name of the usage. The default name is "Usage". You can also change the usage settings (Create, Read, Update, and Delete).</p> 
Delete	<p>When you select a Receiver in the table, the delete option becomes available. This action removes the selected receiver from the usage.</p> 
Show Selected Usages	<p>When you select a Receiver in the table, the Show Selected Usages option () becomes available. Click this icon to display the usage for the selected receiver in the diagram, including the usage settings.</p>
Filter Receiver Types	Opens the Usage Report Filter dialog where you can select the types of objects you want included in the Usage Report.
<a href="#">Export Usage Report</a>	You can export the Usage (CRUD) reports in the following formats: CSV, HTML, PDF, and RTF
<a href="#">Print</a>	Opens the Print dialog where you can select a printer, set preferences, select a page range and number of copies and then print.
Refresh Usage	Updates all the nodes in the Usage Report.



Property View	Description
Impact Analysis	
Filter Designation	<p>Indicates whether a <a href="#">Filter</a> has been set for the Impact Analysis Report.</p> <p>Two icons are displayed to the left of the Filter Designation indicator:</p> <p>Click  to display the impact analysis information in a tree format.</p> <p>Click  to display the impact analysis information in a table format.</p>
<a href="#">Create Impact Analysis Diagram</a>	Once you create a link you can create a diagram that is a graphical representation of that link.
<a href="#">Filter</a>	Opens the Impact Analysis Filter dialog
Export	You can export and save the Impact Analysis report in the following file formats: CSV, HTML, PDF, and RTF.
Print	Opens the Print dialog where you can select a printer, set preferences, select a page range and number of copies and then print.
Expand All	Expands all the nodes in the tree.
Collapse All	Collapses all the nodes in the tree.
Refresh	Updates all the nodes in the Impact Analysis Report.
Appearance	
<a href="#">Font and Color Options</a>	Use these commands to change fonts and element colors.
<a href="#">Rendering</a>	Use these commands to change the shadowing and gradient settings for an element.
<a href="#">Horizontal Alignment</a>	Use these commands to set the justification for text labels in an element.
Diagram Display Options	<p>Show Name: Select this option to show the element label.</p> <p>Show Connection: Select this option to display the line in the diagram.</p>
Line Display Options	Select the width of the border from the drop-down list. You can select from 1 to 5 pixels.
Apply to Diagram	Applies the formatting changes to all existing pools on the active diagram.
Restore Defaults	Restores the default settings for all changes made in the Appearance tab.
Set as Default	All formatting changes made in the Appearance tab become the default settings for new pools placed in the Diagram View.







## Lane

The table below describes the Property View fields available for a Lane:

Property View	Description
General	
Name	Label that appears for an element both in the Model View tree and in the diagram. You can edit this label.
Categories	You can add one or more defined Categories that can be used for purposes such as reporting and analysis.
Parent Pool	The Parent Pool must be specified. There can be only one Parent.
Parent Lane	ParentLane is an optional attribute that is used if the Lane is nested within another Lane. Nesting can be multi-level, but only the immediate parent is specified.
Description	
	<p>A text box where you can enter information describing or defining the project. Right-click text to open a shortcut menu. You can cut, copy, paste, and delete selected text within the Description text box. You can paste plain text from external applications.</p> <p>You can undo any action and you can select all text by pressing Ctrl+A.</p> <p>The following formatting options are available for the text: Bold, Italics, Underscore, and Strikethrough. You can also change the font color as well as the background color.</p>
Notes	
	<p>A text box where you can annotate the element with additional information. Right-click text to open a shortcut menu. You can cut, copy, paste, and delete selected text within the Notes text box. You can paste plain text from external applications.</p> <p>You can undo any action and you can select all text by pressing Ctrl+A.</p> <p>The following formatting options are available for the text: Bold, Italics, Underscore, and Strikethrough. You can also change the font color as well as the background color.</p>
Links	
Add Link	Opens the <a href="#">Create Link</a> wizard. This wizard allows you to create conceptual or usage links between elements.
Edit Link	Opens the property view for the selected link.
Delete Link	Deletes the selected link (either the link or the link target).
Show Selected Links on Active Diagram	Once you have created a link in the Diagram View, click this icon to display the links for the selected object in the diagram.

Property View	Description
Expand All	Expands all the nodes in the tree.
Collapse All	Collapses all the nodes in the tree.
Refresh Links	Updates all the nodes in the Link Report.
Usage (CRUD)	
Usage	<p>The header displays the name of the linked element and the status of the filter (on or off).</p> <p>Receivers: Displays a list of the elements with usages (receivers). You can select multiple receivers in this list and delete all the receivers that are selected.</p> <p>Usage: Displays the usage setting (C, R, U, D). You can change the Usage attributes in this column and this change is reflected in the diagram. For example, you can change a C (Create) type to a U (Update) type.</p> <p>Usage Description: Displays the information entered in the Description text field for the target object of the usage. For example, if a usage was drawn between a task and a Data Store object, the description of the Data Store object is displayed.</p> <p>If there are no links or all the links have been filtered out, you are given the information that "No usages have been defined for this element" in the Receivers column.</p>
<a href="#">Add Usage</a>	Opens the Create Usage wizard where you can create a new usage.
<a href="#">Edit Usage</a>	<p>When you select a Receiver in the table, the edit option becomes available. Click this to open the Usage edit tab where you can edit the name of the usage. The default name is "Usage". You can also change the usage settings (Create, Read, Update, and Delete).</p> 
Delete	<p>When you select a Receiver in the table, the delete option becomes available. This action removes the selected receiver from the usage.</p> 
Show Selected Usages	<p>When you select a Receiver in the table, the Show Selected Usages option () becomes available. Click this icon to display the usage for the selected receiver in the diagram, including the usage settings.</p>
Filter Receiver Types	Opens the Usage Report Filter dialog where you can select the types of objects you want included in the Usage Report.
<a href="#">Export Usage Report</a>	You can export the Usage (CRUD) reports in the following formats: CSV, HTML, PDF, and RTF
<a href="#">Print</a>	Opens the Print dialog where you can select a printer, set preferences, select a page range and number of copies and then print.
Refresh Usage	Updates all the nodes in the Usage Report.



Property View	Description
Impact Analysis	
Filter Designation	<p>Indicates whether a <a href="#">Filter</a> has been set for the Impact Analysis Report.</p> <p>Two icons are displayed to the left of the Filter Designation indicator:</p> <p> Click  to display the impact analysis information in a tree format.</p> <p> Click  to display the impact analysis information in a table format.</p>
<a href="#">Create Impact Analysis Diagram</a>	Once you create a link you can create a diagram that is a graphical representation of that link.
<a href="#">Filter</a>	Opens the Impact Analysis Filter dialog
Export	You can export and save the Impact Analysis report in the following file formats: CSV, HTML, PDF, and RTF.
Print	Opens the Print dialog where you can select a printer, set preferences, select a page range and number of copies and then print.
Expand All	Expands all the nodes in the tree.
Collapse All	Collapses all the nodes in the tree.
Refresh	Updates all the nodes in the Impact Analysis Report.
Appearance	
<a href="#">Font and Color Options</a>	Use these commands to change fonts and element colors.
<a href="#">Horizontal Alignment</a>	Use these commands to set the justification for text labels in an element.
Diagram Display Options	Show Name: Select this option to show the element label.
Apply to Diagram	Applies the formatting changes to all existing lanes on the active diagram.
Restore Defaults	Restores the default settings for all changes made in the Appearance tab.
Set as Default	All formatting changes made in the Appearance tab become the default settings for new lanes placed in the Diagram View.





### Nested Lane

The table below describes the Property View fields available for a Nested Lane:

Property View	Description
General	
Name	Label that appears for an element both in the Model View tree and in the diagram. You can edit this label.
Categories	You can add one or more defined Categories that can be used for purposes such as reporting and analysis.



Property View	Description
Parent Pool	The Parent Pool must be specified. There can be only one Parent.
Parent Lane	ParentLane is an optional attribute that is used if the Lane is nested within another Lane. Nesting can be multi-level, but only the immediate parent is specified.
Description	
	<p>A text box where you can enter information describing or defining the project. Right-click text to open a shortcut menu. You can cut, copy, paste, and delete selected text within the Description text box. You can paste plain text from external applications.</p> <p>You can undo any action and you can select all text by pressing Ctrl+A.</p> <p>The following formatting options are available for the text: Bold, Italics, Underscore, and Strikethrough. You can also change the font color as well as the background color.</p>
Notes	
	<p>A text box where you can annotate the element with additional information. Right-click text to open a shortcut menu. You can cut, copy, paste, and delete selected text within the Notes text box. You can paste plain text from external applications.</p> <p>You can undo any action and you can select all text by pressing Ctrl+A.</p> <p>The following formatting options are available for the text: Bold, Italics, Underscore, and Strikethrough. You can also change the font color as well as the background color.</p>
Links	
Add Link	Opens the <a href="#">Create Link</a> wizard. This wizard allows you to create conceptual or usage links between elements.
Edit Link	Opens the property view for the selected link.
Delete Link	Deletes the selected link (either the link or the link target).
Show Selected Links on Active Diagram	Once you have created a link in the Diagram View, click this icon to display the links for the selected object in the diagram.
Expand All	Expands all the nodes in the tree.
Collapse All	Collapses all the nodes in the tree.
Refresh Links	Updates all the nodes in the Link Report.

Property View	Description
Usage (CRUD)	
Usage	<p>The header displays the name of the linked element and the status of the filter (on or off).</p> <p>Receivers: Displays a list of the elements with usages (receivers). You can select multiple receivers in this list and delete all the receivers that are selected.</p> <p>Usage: Displays the usage setting (C, R, U, D). You can change the Usage attributes in this column and this change is reflected in the diagram. For example, you can change a C (Create) type to a U (Update) type.</p> <p>Usage Description: Displays the information entered in the Description text field for the target object of the usage. For example, if a usage was drawn between a task and a Data Store object, the description of the Data Store object is displayed.</p> <p>If there are no links or all the links have been filtered out, you are given the information that "No usages have been defined for this element" in the Receivers column.</p>
<a href="#">Add Usage</a>	Opens the Create Usage wizard where you can create a new usage.
<a href="#">Edit Usage</a>	<p>When you select a Receiver in the table, the edit option becomes available. Click this to open the Usage edit tab where you can edit the name of the usage. The default name is "Usage". You can also change the usage settings (Create, Read, Update, and Delete).</p> 
Delete	<p>When you select a Receiver in the table, the delete option becomes available. This action removes the selected receiver from the usage.</p> 
Show Selected Usages	<p>When you select a Receiver in the table, the Show Selected Usages option () becomes available. Click this icon to display the usage for the selected receiver in the diagram, including the usage settings.</p>
Filter Receiver Types	Opens the Usage Report Filter dialog where you can select the types of objects you want included in the Usage Report.
<a href="#">Export Usage Report</a>	You can export the Usage (CRUD) reports in the following formats: CSV, HTML, PDF, and RTF
<a href="#">Print</a>	Opens the Print dialog where you can select a printer, set preferences, select a page range and number of copies and then print.
Refresh Usage	Updates all the nodes in the Usage Report.



Property View	Description
Impact Analysis	
Filter Designation	<p>Indicates whether a <a href="#">Filter</a> has been set for the Impact Analysis Report.</p> <p>Two icons are displayed to the left of the Filter Designation indicator:</p> <p> Click  to display the impact analysis information in a tree format.</p> <p> Click  to display the impact analysis information in a table format.</p>
<a href="#">Create Impact Analysis Diagram</a>	Once you create a link you can create a diagram that is a graphical representation of that link.
<a href="#">Filter</a>	Opens the Impact Analysis Filter dialog
Export	You can export and save the Impact Analysis report in the following file formats: CSV, HTML, PDF, and RTF.
Print	Opens the Print dialog where you can select a printer, set preferences, select a page range and number of copies and then print.
Expand All	Expands all the nodes in the tree.
Collapse All	Collapses all the nodes in the tree.
Refresh	Updates all the nodes in the Impact Analysis Report.
Appearance	
<a href="#">Font and Color Options</a>	Use these commands to change fonts and element colors.
<a href="#">Horizontal Alignment</a>	Use these commands to set the justification for text labels in an element.
Diagram Display Options	Show name: Displays the label of the Association object. This option is selected by default.
Apply to Diagram	Applies the formatting changes to all existing nested lanes on the active diagram.
Restore Defaults	Restores the default settings for all changes made in the Appearance tab.
Set as Default	All formatting changes made in the Appearance tab become the default settings for new nested lanes placed in the Diagram View.





## Process

Property View	Description
General	
Name	Label that appears for an element both in the Model View tree and in the diagram. You can edit this label.
Categories	You can add one or more defined Categories that can be used for purposes such as reporting and analysis.
Process type:	This maps to a BPEL4WS <i>scope</i> element. The scope is not an independent <i>process</i> and will share the <i>process variables</i> of the higher-level <i>process</i> .
Status	
<a href="#">Ad hoc</a>	Ad hoc is a boolean attribute, which has a default of False. This specifies whether the Embedded Sub-Process is Ad Hoc or not. The activities within an Ad Hoc Embedded Sub-Process are not controlled or sequenced in a particular order, there performance is determined by the performers of the activities. <b>Note:</b> You can set this attribute for multiple subprocesses.
Suppress Join Failure	A join condition provides status about an incoming link. A join failure indicates that link execution failed. At the process level, this attribute specifies whether a join failure is suppressed for the whole process.
Enable Instance Compensation	This attribute is included for mapping to BPEL4WS. It specifies whether or not a compensation can be performed after the Process has completed normally.
Description	
	<p>A text box where you can enter information describing or defining the project. Right-click text to open a shortcut menu. You can cut, copy, paste, and delete selected text within the Description text box. You can paste plain text from external applications.</p> <p>You can undo any action and you can select all text by pressing Ctrl+A.</p> <p>The following formatting options are available for the text: Bold, Italics, Underscore, and Strikethrough. You can also change the font color as well as the background color.</p>

Property View	Description
Notes	
	<p>A text box where you can annotate the element with additional information. Right-click text to open a shortcut menu. You can cut, copy, paste, and delete selected text within the Notes text box. You can paste plain text from external applications.</p> <p>You can undo any action and you can select all text by pressing Ctrl+A.</p> <p>The following formatting options are available for the text: Bold, Italics, Underscore, and Strikethrough. You can also change the font color as well as the background color</p>
Assignments	
Name	Label that appears for an element both in the Model View tree and in the diagram. You can edit this label.
To	The target for the Assignment must be a Property of the Process or the activity itself.
From	The Expression must be made up of a combination of Values, Properties, and Attributes, which are separated by operators such as add or multiply. The expression language is defined in the ExpressionLanguage attribute of the Business Process Diagram.
Assign Time	<p>An Assignment may have a AssignTime setting. If the Object is an activity (Task, Sub-Process, or Process), then the Assignment must have an AssignTime. A value of Start means that the assignment shall occur at the start of the activity. This can be used to assign the higher-level (global) Properties of the Process to the (local) Properties of the activity as an input to the activity.</p> <p>A value of End means that the assignment shall occur at the end of the activity. This can be used to assign the (local) Properties of the activity to the higher-level (global) Properties of the Process as an output to the activity.</p>
Create Assignment	Click  to create a new assignment for the element.
<a href="#">Edit Assignment</a>	When you click edit  an additional tab opens where you can edit the selected assignments.
Delete Assignment	Deletes the selected assignment.
Properties	
Name	Modeler-defined Properties may be added to an activity. These Properties are "local" to the activity and are only for use within the processing of the activity. The fully delineated name of these properties is "<process name>.<activity name>.<property name>". You can add, <a href="#">edit</a> and delete these properties.



Property View	Description
Type	Each Property has a Type (for example, type="String"). A Property may be of type Set, which allows child Properties.
Correlation	If the ConditionType attribute is set to Expression, then the ConditionExpression attribute must be defined. Otherwise, it is not valid. This attribute is included for mapping to BPEL4WS. The Property will map to a <i>correlationSet</i> and the child Properties will be <i>properties</i> of that <i>correlationSet</i> .
Links	
Add Link	Opens the <a href="#">Create Link</a> wizard. This wizard allows you to create conceptual or usage links between elements.
Edit Link	Opens the property view for the selected link.
Delete Link	Deletes the selected link (either the link or the link target).
Show Selected Links on Active Diagram	Once you have created a link in the Diagram View, click this icon to display the links for the selected object in the diagram.
Expand All	Expands all the nodes in the tree.
Collapse All	Collapses all the nodes in the tree.
Refresh Links	Updates all the nodes in the Link Report.
Usage (CRUD)	
Usage	<p>The header displays the name of the linked element and the status of the filter (on or off).</p> <p>Receivers: Displays a list of the elements with usages (receivers). You can select multiple receivers in this list and delete all the receivers that are selected.</p> <p>Usage: Displays the usage setting (C, R, U, D). You can change the Usage attributes in this column and this change is reflected in the diagram. For example, you can change a C (Create) type to a U (Update) type.</p> <p>Usage Description: Displays the information entered in the Description text field for the target object of the usage. For example, if a usage was drawn between a task and a Data Store object, the description of the Data Store object is displayed.</p> <p>If there are no links or all the links have been filtered out, you are given the information that "No usages have been defined for this element" in the Receivers column.</p>
<a href="#">Add Usage</a>	Opens the Create Usage wizard where you can create a new usage.
<a href="#">Edit Usage</a>	When you select a Receiver in the table, the edit option becomes available. Click this to open the Usage edit tab where you can edit the name of the usage. The default name is "Usage". You can also change the usage settings (Create, Read, Update, and Delete). 
Delete	When you select a Receiver in the table, the delete option becomes available. This action removes the selected receiver from the usage. 

Property View	Description
Show Selected Usages	When you select a Receiver in the table, the Show Selected Usages option (  ) becomes available. Click this icon to display the usage for the selected receiver in the diagram, including the usage settings.
Filter Receiver Types	Opens the Usage Report Filter dialog where you can select the types of objects you want included in the Usage Report.
<a href="#">Export Usage Report</a>	You can export the Usage (CRUD) reports in the following formats: CSV, HTML, PDF, and RTF
<a href="#">Print</a>	Opens the Print dialog where you can select a printer, set preferences, select a page range and number of copies and then print.
Refresh Usage	Updates all the nodes in the Usage Report.
Impact Analysis	
Filter Designation	Indicates whether a <a href="#">Filter</a> has been set for the Impact Analysis Report. Two icons are displayed to the left of the Filter Designation indicator:   Click  to display the impact analysis information in a tree format.   Click  to display the impact analysis information in a table format.
<a href="#">Create Impact Analysis Diagram</a>	Once you create a link you can create a diagram that is a graphical representation of that link.
<a href="#">Filter</a>	Opens the Impact Analysis Filter dialog
Export	You can export and save the Impact Analysis report in the following file formats: CSV, HTML, PDF, and RTF.
Print	Opens the Print dialog where you can select a printer, set preferences, select a page range and number of copies and then print.
Expand All	Expands all the nodes in the tree.
Collapse All	Collapses all the nodes in the tree.
Refresh	Updates all the nodes in the Impact Analysis Report.

## Artifacts







Artifacts provide additional information about the business process. Using artifacts allows you to add non-standard elements to satisfy a specific need. Since you do not want to alter the basic look-and-feel of a diagram, you can use artifacts to link to the existing events and activities through Associations. Artifacts do not affect the basic Sequence or Message Flow, nor do they affect mapping to execution languages. The Artifacts include: [Data Object](#), [Group](#), [Annotation](#), and the [Off-Page Connector](#).

## Data Object

The table below describes the Property View fields available for a Data Object:

Property View	Description
General	
Name	Label that appears for an element both in the Model View tree and in the diagram. You can edit this label.
Categories	You can add one or more defined Categories that can be used for purposes such as reporting and analysis.
State	<p>State is an optional attribute that indicates the impact the Process has had on the Data Object. Multiple Data Objects with the same name may share the same state within one Process.</p> <p><b>Required for Start:</b> The default value for this attribute is True. This means that the Input is required for the activity to start. If set to False, then the activity may start within the input, but may accept the input (more than once) after the activity has started.</p> <p><b>Produced at Completion:</b> The default value for this attribute is True. This means that the Output is produced when the activity has been completed. If set to False, then the activity may produce the output (more than once) before it has completed.</p>
Description	
	<p>A text box where you can enter information describing or defining the project. Right-click text to open a shortcut menu. You can cut, copy, paste, and delete selected text within the Description text box. You can paste plain text from external applications.</p> <p>You can undo any action and you can select all text by pressing Ctrl+A.</p> <p>The following formatting options are available for the text: Bold, Italics, Underscore, and Strikethrough. You can also change the font color as well as the background color.</p>
Notes	
	<p>A text box where you can annotate the element with additional information. Right-click text to open a shortcut menu. You can cut, copy, paste, and delete selected text within the Notes text box. You can paste plain text from external applications.</p> <p>You can undo any action and you can select all text by pressing Ctrl+A.</p> <p>The following formatting options are available for the text: Bold, Italics, Underscore, and Strikethrough. You can also change the font color as well as the background color.</p>

Property View	Description
Properties	
Name	Modeler-defined Properties may be added to an activity. These Properties are "local" to the activity and are only for use within the processing of the activity. The fully delineated name of these properties is "<process name>.<activity name>.<property name>". You can add, <a href="#">edit</a> and delete these properties.
Type	Each Property has a Type (e.g., type="String"). A Property may be of type Set, which allows child Properties.
Correlation	If the ConditionType attribute is set to Expression, then the ConditionExpression attribute MUST be defined. Otherwise, it is not valid. This attribute is included for mapping to BPEL4WS. The Property will map to a <i>correlationSet</i> and the child Properties will be <i>properties</i> of that <i>correlationSet</i> .
Links	
Add Link	Opens the <a href="#">Create Link</a> wizard. This wizard allows you to create conceptual or usage links between elements.
Edit Link	Opens the property view for the selected link.
Delete Link	Deletes the selected link (either the link or the link target).
Show Selected Links on Active Diagram	Once you have created a link in the Diagram View, click this icon to display the links for the selected object in the diagram.
Expand All	Expands all the nodes in the tree.
Collapse All	Collapses all the nodes in the tree.
Refresh Links	Updates all the nodes in the Link Report.
Usage (CRUD)	
Usage	<p>The header displays the name of the linked element and the status of the filter (on or off).</p> <p>Receivers: Displays a list of the elements with usages (receivers). You can select multiple receivers in this list and delete all the receivers that are selected.</p> <p>Usage: Displays the usage setting (C, R, U, D). You can change the Usage attributes in this column and this change is reflected in the diagram. For example, you can change a C (Create) type to a U (Update) type.</p> <p>Usage Description: Displays the information entered in the Description text field for the target object of the usage. For example, if a usage was drawn between a task and a Data Store object, the description of the Data Store object is displayed.</p> <p>If there are no links or all the links have been filtered out, you are given the information that "No usages have been defined for this element" in the Receivers column.</p>
<a href="#">Add Usage</a>	Opens the Create Usage wizard where you can create a new usage.

Property View	Description
<a href="#">Edit Usage</a>	When you select a Receiver in the table, the edit option becomes available. Click this to open the Usage edit tab where you can edit the name of the usage. The default name is "Usage". You can also change the usage settings (Create, Read, Update, and Delete). 
Delete	When you select a Receiver in the table, the delete option becomes available. This action removes the selected receiver from the usage. 
Show Selected Usages	When you select a Receiver in the table, the Show Selected Usages option (  ) becomes available. Click this icon to display the usage for the selected receiver in the diagram, including the usage settings.
Filter Receiver Types	Opens the Usage Report Filter dialog where you can select the types of objects you want included in the Usage Report.
<a href="#">Export Usage Report</a>	You can export the Usage (CRUD) reports in the following formats: CSV, HTML, PDF, and RTF
<a href="#">Print</a>	Opens the Print dialog where you can select a printer, set preferences, select a page range and number of copies and then print.
Refresh Usage	Updates all the nodes in the Usage Report.
Impact Analysis	
Filter Designation	Indicates whether a <a href="#">Filter</a> has been set for the Impact Analysis Report. Two icons are displayed to the left of the Filter Designation indicator:  Click  to display the impact analysis information in a tree format.  Click  to display the impact analysis information in a table format.
<a href="#">Create Impact Analysis Diagram</a>	Once you create a link you can create a diagram that is a graphical representation of that link.
<a href="#">Filter</a>	Opens the Impact Analysis Filter dialog
Export	You can export and save the Impact Analysis report in the following file formats: CSV, HTML, PDF, and RTF.
Print	Opens the Print dialog where you can select a printer, set preferences, select a page range and number of copies and then print.
Expand All	Expands all the nodes in the tree.
Collapse All	Collapses all the nodes in the tree.
Refresh	Updates all the nodes in the Impact Analysis Report.
Appearance	
<a href="#">Font and Color Options</a>	Use these commands to change fonts and element colors.







Property View	Description
<a href="#">Rendering</a>	Use these commands to change the shadowing and gradient settings for an element.
<a href="#">Horizontal Alignment</a>	Use these commands to set the justification for text labels in an element.
Diagram Display Options	Show name: Displays the label of the Association object. This option is selected by default. Show state: Displays the state information you entered in the State text field on the General tab.
Apply to Diagram	Applies the formatting changes to all existing data objects on the active diagram.
Restore Defaults	Restores the default settings for all changes made in the Appearance tab.
Set as Default	All formatting changes made in the Appearance tab become the default settings for new data objects placed in the Diagram View.

### Group

The table below describes the Property View fields available for a Group:

Property View	Description
General	
Name	Label that appears for an element both in the Model View tree and in the diagram. You can edit this label.
Categories	You can add one or more defined Categories that can be used for purposes such as reporting and analysis.
Description	
	<p>A text box where you can enter information describing or defining the project. Right-click text to open a shortcut menu. You can cut, copy, paste, and delete selected text within the Description text box. You can paste plain text from external applications.</p> <p>You can undo any action and you can select all text by pressing Ctrl+A.</p> <p>The following formatting options are available for the text: Bold, Italics, Underscore, and Strikethrough. You can also change the font color as well as the background color.</p>

Property View	Description
Notes	
	<p>A text box where you can annotate the element with additional information. Right-click text to open a shortcut menu. You can cut, copy, paste, and delete selected text within the Notes text box. You can paste plain text from external applications.</p> <p>You can undo any action and you can select all text by pressing Ctrl+A.</p> <p>The following formatting options are available for the text: Bold, Italics, Underscore, and Strikethrough. You can also change the font color as well as the background color</p>
Links	
Add Link	Opens the <a href="#">Create Link</a> wizard. This wizard allows you to create conceptual or usage links between elements.
Edit Link	Opens the property view for the selected link.
Delete Link	Deletes the selected link (either the link or the link target).
Show Selected Links on Active Diagram	Once you have created a link in the Diagram View, click this icon to display the links for the selected object in the diagram.
Expand All	Expands all the nodes in the tree.
Collapse All	Collapses all the nodes in the tree.
Refresh Links	Updates all the nodes in the Link Report.
Usage (CRUD)	
Usage	<p>The header displays the name of the linked element and the status of the filter (on or off).</p> <p>Receivers: Displays a list of the elements with usages (receivers). You can select multiple receivers in this list and delete all the receivers that are selected.</p> <p>Usage: Displays the usage setting (C, R, U, D). You can change the Usage attributes in this column and this change is reflected in the diagram. For example, you can change a C (Create) type to a U (Update) type.</p> <p>Usage Description: Displays the information entered in the Description text field for the target object of the usage. For example, if a usage was drawn between a task and a Data Store object, the description of the Data Store object is displayed.</p> <p>If there are no links or all the links have been filtered out, you are given the information that "No usages have been defined for this element" in the Receivers column.</p>
<a href="#">Add Usage</a>	Opens the Create Usage wizard where you can create a new usage.
<a href="#">Edit Usage</a>	<p>When you select a Receiver in the table, the edit option becomes available. Click this to open the Usage edit tab where you can edit the name of the usage. The default name is "Usage". You can also change the usage settings (Create, Read, Update, and Delete).</p> 

Property View	Description
Delete	When you select a Receiver in the table, the delete option becomes available. This action removes the selected receiver from the usage. 
Show Selected Usages	When you select a Receiver in the table, the Show Selected Usages option (  ) becomes available. Click this icon to display the usage for the selected receiver in the diagram, including the usage settings.
Filter Receiver Types	Opens the Usage Report Filter dialog where you can select the types of objects you want included in the Usage Report.
<a href="#">Export Usage Report</a>	You can export the Usage (CRUD) reports in the following formats: CSV, HTML, PDF, and RTF
<a href="#">Print</a>	Opens the Print dialog where you can select a printer, set preferences, select a page range and number of copies and then print.
Refresh Usage	Updates all the nodes in the Usage Report.
Impact Analysis	
Filter Designation	Indicates whether a <a href="#">Filter</a> has been set for the Impact Analysis Report. Two icons are displayed to the left of the Filter Designation indicator:  Click  to display the impact analysis information in a tree format.  Click  to display the impact analysis information in a table format.
<a href="#">Create Impact Analysis Diagram</a>	Once you create a link you can create a diagram that is a graphical representation of that link.
<a href="#">Filter</a>	Opens the Impact Analysis Filter dialog
Export	You can export and save the Impact Analysis report in the following file formats: CSV, HTML, PDF, and RTF.
Print	Opens the Print dialog where you can select a printer, set preferences, select a page range and number of copies and then print.
Expand All	Expands all the nodes in the tree.
Collapse All	Collapses all the nodes in the tree.
Refresh	Updates all the nodes in the Impact Analysis Report.
Appearance	
<a href="#">Font and Color Options</a>	Use these commands to change fonts and element colors. Note that the element fill command is unavailable for the Group element.
<a href="#">Horizontal Alignment</a>	Use these commands to set the justification for text labels in an element.
Diagram Display Options	Show name: Displays the label of the Association object. This option is selected by default.







Property View	Description
Line Display Options	Select the width of the border from the drop-down list. You can select from 1 to 5 pixels.
Apply to Diagram	Applies the formatting changes to all existing group objects on the active diagram.
Restore Defaults	Restores the default settings for all changes made in the Appearance tab.
Set as Default	All formatting changes made in the Appearance tab become the default settings for new group objects placed in the Diagram View.

### Annotation

The table below describes the Property View fields available for an Annotation:

Property View	Description
General	
Name	Label that appears for an element both in the Model View tree and in the diagram. You can edit this label.
Categories	You can add one or more defined Categories that can be used for purposes such as reporting and analysis.
Text	Descriptive text for the Annotation element.
Description	
	<p>A text box where you can enter information describing or defining the project. Right-click text to open a shortcut menu. You can cut, copy, paste, and delete selected text within the Description text box. You can paste plain text from external applications.</p> <p>You can undo any action and you can select all text by pressing Ctrl+A.</p> <p>The following formatting options are available for the text: Bold, Italics, Underscore, and Strikethrough. You can also change the font color as well as the background color.</p>
Notes	
	<p>A text box where you can annotate the element with additional information. Right-click text to open a shortcut menu. You can cut, copy, paste, and delete selected text within the Notes text box. You can paste plain text from external applications.</p> <p>You can undo any action and you can select all text by pressing Ctrl+A.</p> <p>The following formatting options are available for the text: Bold, Italics, Underscore, and Strikethrough. You can also change the font color as well as the background color.</p>

Property View	Description
Links	
Add Link	Opens the <a href="#">Create Link</a> wizard. This wizard allows you to create conceptual or usage links between elements.
Edit Link	Opens the property view for the selected link.
Delete Link	Deletes the selected link (either the link or the link target).
Show Selected Links on Active Diagram	Once you have created a link in the Diagram View, click this icon to display the links for the selected object in the diagram.
Expand All	Expands all the nodes in the tree.
Collapse All	Collapses all the nodes in the tree.
Refresh Links	Updates all the nodes in the Link Report.
Usage (CRUD)	
Usage	<p>The header displays the name of the linked element and the status of the filter (on or off).</p> <p>Receivers: Displays a list of the elements with usages (receivers). You can select multiple receivers in this list and delete all the receivers that are selected.</p> <p>Usage: Displays the usage setting (C, R, U, D). You can change the Usage attributes in this column and this change is reflected in the diagram. For example, you can change a C (Create) type to a U (Update) type.</p> <p>Usage Description: Displays the information entered in the Description text field for the target object of the usage. For example, if a usage was drawn between a task and a Data Store object, the description of the Data Store object is displayed.</p> <p>If there are no links or all the links have been filtered out, you are given the information that "No usages have been defined for this element" in the Receivers column.</p>
<a href="#">Add Usage</a>	Opens the Create Usage wizard where you can create a new usage.
<a href="#">Edit Usage</a>	When you select a Receiver in the table, the edit option becomes available. Click this to open the Usage edit tab where you can edit the name of the usage. The default name is "Usage". You can also change the usage settings (Create, Read, Update, and Delete). 
Delete	When you select a Receiver in the table, the delete option becomes available. This action removes the selected receiver from the usage. 
Show Selected Usages	When you select a Receiver in the table, the Show Selected Usages option (  ) becomes available. Click this icon to display the usage for the selected receiver in the diagram, including the usage settings.
Filter Receiver Types	Opens the Usage Report Filter dialog where you can select the types of objects you want included in the Usage Report.
<a href="#">Export Usage Report</a>	You can export the Usage (CRUD) reports in the following formats: CSV, HTML, PDF, and RTF

Property View	Description
<a href="#">Print</a>	Opens the Print dialog where you can select a printer, set preferences, select a page range and number of copies and then print.
Refresh Usage	Updates all the nodes in the Usage Report.
Impact Analysis	
Filter Designation	<p>Indicates whether a <a href="#">Filter</a> has been set for the Impact Analysis Report.</p> <p>Two icons are displayed to the left of the Filter Designation indicator:</p> <p>Click  to display the impact analysis information in a tree format.</p> <p>Click  to display the impact analysis information in a table format.</p>
<a href="#">Create Impact Analysis Diagram</a>	Once you create a link you can create a diagram that is a graphical representation of that link.
<a href="#">Filter</a>	Opens the Impact Analysis Filter dialog
Export	You can export and save the Impact Analysis report in the following file formats: CSV, HTML, PDF, and RTF.
Print	Opens the Print dialog where you can select a printer, set preferences, select a page range and number of copies and then print.
Expand All	Expands all the nodes in the tree.
Collapse All	Collapses all the nodes in the tree.
Refresh	Updates all the nodes in the Impact Analysis Report.
Appearance	
<a href="#">Font and Color Options</a>	Use these commands to change fonts and element colors. Note that the element fill command is unavailable for the Annotation element.
<a href="#">Horizontal Alignment</a>	Use these commands to set the justification for text labels in an element.
Diagram Display Options	<b>Show name:</b> Displays the label of the Association object. This option is selected by default.
Line Display Options	Select the width of the border from the drop-down list. You can select from 1 to 5 pixels.
Apply to Diagram	Applies the formatting changes to all existing annotation objects on the active diagram.
Restore Defaults	Restores the default settings for all changes made in the Appearance tab.
Set as Default	All formatting changes made in the Appearance tab become the default settings for new annotation objects placed in the Diagram View.

## Off-Page Connector

The table below describes the Property View fields available for an Off-Page Connector:

Property View	Description
General	
Name	Label that appears for an element both in the Model View tree and in the diagram. You can edit this label.
Categories	You can add one or more defined Categories that can be used for purposes such as reporting and analysis.
Description	
	<p>A text box where you can enter information describing or defining the project. Right-click text to open a shortcut menu. You can cut, copy, paste, and delete selected text within the Description text box. You can paste plain text from external applications.</p> <p>You can undo any action and you can select all text by pressing Ctrl+A.</p> <p>The following formatting options are available for the text: Bold, Italics, Underscore, and Strikethrough. You can also change the font color as well as the background color.</p>
Notes	
	<p>A text box where you can annotate the element with additional information. Right-click text to open a shortcut menu. You can cut, copy, paste, and delete selected text within the Notes text box. You can paste plain text from external applications.</p> <p>You can undo any action and you can select all text by pressing Ctrl+A.</p> <p>The following formatting options are available for the text: Bold, Italics, Underscore, and Strikethrough. You can also change the font color as well as the background color.</p>
Appearance	
<a href="#">Font and Color Options</a>	Use these commands to change fonts and element colors. Note that the element fill command is unavailable for the Group element.
<a href="#">Rendering</a>	Use these commands to change the shadowing and gradient settings for an element.
<a href="#">Horizontal Alignment</a>	Use these commands to set the justification for text labels in an element.
Diagram Display Options	Show name: Displays the label of the Association object. This option is selected by default.
Apply to Diagram	Applies the formatting changes to all existing off-page connectors on the active diagram.

Property View	Description
Restore Defaults	Restores the default settings for all changes made in the Appearance tab.
Set as Default	All formatting changes made in the Appearance tab become the default settings for new off-page connectors placed in the Diagram View.





## Conceptual modeling diagram elements





There are five Conceptual Data Modeling diagram elements: [Subject Area](#), [Business Entity](#), [Business Attribute Interaction](#), and [Relationship](#).

### Subject Area

The table below describes the Property View fields available for a Subject Area Object:

Property View	Description
General	
Name	Label that appears for an element both in the Model View tree and in the diagram. You can edit this label.
Description	
	<p>A text box where you can enter information describing or defining the project. Right-click text to open a shortcut menu. You can cut, copy, paste, and delete selected text within the Description text box. You can paste plain text from external applications.</p> <p>You can undo any action and you can select all text by pressing Ctrl+A.</p> <p>The following formatting options are available for the text: Bold, Italics, Underscore, and Strikethrough. You can also change the font color as well as the background color.</p>
Notes	
	<p>A text box where you can annotate the element with additional information. Right-click text to open a shortcut menu. You can cut, copy, paste, and delete selected text within the Notes text box. You can paste plain text from external applications.</p> <p>You can undo any action and you can select all text by pressing Ctrl+A.</p> <p>The following formatting options are available for the text: Bold, Italics, Underscore, and Strikethrough. You can also change the font color as well as the background color.</p>

Property View	Description
Mappings	
Create Mapping	Click  to open the <a href="#">Create Mapping</a> dialog.
Edit Target	Click  to open the Property View for the targeted element.
Remove Target from Mapping	The deleted target is no longer mapped.
Links	
Add Link	Opens the <a href="#">Create Link</a> wizard. This wizard allows you to create conceptual or usage links between elements.
Edit Link	Opens the property view for the selected link.
Delete Link	Deletes the selected link (either the link or the link target).
Show Selected Links on Active Diagram	Once you have created a link in the Diagram View, click this icon to display the links for the selected object in the diagram.
Expand All	Expands all the nodes in the tree.
Collapse All	Collapses all the nodes in the tree.
Refresh Links	Updates all the nodes in the Link Report.
Usage (CRUD)	
Usage	<p>The header displays the name of the linked element and the status of the filter (on or off).</p> <p>Receivers: Displays a list of the elements with usages (receivers). You can select multiple receivers in this list and delete all the receivers that are selected.</p> <p>Usage: Displays the usage setting (C, R, U, D). You can change the Usage attributes in this column and this change is reflected in the diagram. For example, you can change a C (Create) type to a U (Update) type.</p> <p>Usage Description: Displays the information entered in the Description text field for the target object of the usage. For example, if a usage was drawn between a task and a Data Store object, the description of the Data Store object is displayed.</p> <p>If there are no links or all the links have been filtered out, you are given the information that "No usages have been defined for this element" in the Receivers column.</p>
<a href="#">Add Usage</a>	Opens the Create Usage wizard where you can create a new usage.
<a href="#">Edit Usage</a>	When you select a Receiver in the table, the edit option becomes available. Click this to open the Usage edit tab where you can edit the name of the usage. The default name is "Usage". You can also change the usage settings (Create, Read, Update, and Delete). 
Delete	When you select a Receiver in the table, the delete option becomes available. This action removes the selected receiver from the usage. 

Property View	Description
Show Selected Usages	When you select a Receiver in the table, the Show Selected Usages option (  ) becomes available. Click this icon to display the usage for the selected receiver in the diagram, including the usage settings.
Filter Receiver Types	Opens the Usage Report Filter dialog where you can select the types of objects you want included in the Usage Report.
<a href="#">Export Usage Report</a>	You can export the Usage (CRUD) reports in the following formats: CSV, HTML, PDF, and RTF
<a href="#">Print</a>	Opens the Print dialog where you can select a printer, set preferences, select a page range and number of copies and then print.
Refresh Usage	Updates all the nodes in the Usage Report.
Impact Analysis	
Filter Designation	Indicates whether a <a href="#">Filter</a> has been set for the Impact Analysis Report. Two icons are displayed to the left of the Filter Designation indicator:   Click  to display the impact analysis information in a tree format.   Click  to display the impact analysis information in a table format.
<a href="#">Create Impact Analysis Diagram</a>	Once you create a link you can create a diagram that is a graphical representation of that link.
<a href="#">Filter</a>	Opens the Impact Analysis Filter dialog
Export	You can export and save the Impact Analysis report in the following file formats: CSV, HTML, PDF, and RTF.
Print	Opens the Print dialog where you can select a printer, set preferences, select a page range and number of copies and then print.
Expand All	Expands all the nodes in the tree.
Collapse All	Collapses all the nodes in the tree.
Refresh	Updates all the nodes in the Impact Analysis Report.
Appearance	
<a href="#">Font and Color Options</a>	Use these commands to change fonts and element colors.
<a href="#">Rendering</a>	Use these commands to change the shadowing and gradient settings for an element.
<a href="#">Horizontal Alignment</a>	Use these commands to set the justification for text labels in an element.
<a href="#">Vertical Alignment</a>	Use these commands to place the text in the top, center, or bottom of an element.



Property View	Description
Diagram Display Options	<p>Show name: Displays the label of the Subject Area object. This option is selected by default.</p> <p>Show Expansion Control: You can hide or show the expander indicator located in the lower right-hand corner of the object. The expander is shown as the default setting.</p>
Line Display Options	Select the width of the border from the drop-down list. You can select from 1 to 5 pixels.
Shape	You can display the Subject Area object as an oval or as a squared-edge box. The default setting is as an oval.
Apply to Diagram	Applies the formatting changes to all existing start events on the active diagram.
Restore Defaults	Restores the default settings for all changes made in the Appearance tab.
Set as Default	All formatting changes made in the Appearance tab become the default settings for new start event elements placed in the Diagram View.



### Business Entity



The table below describes the Property View fields available for a Business Entity:

Property View	Description
General	
Name	Label that appears for an element both in the Model View tree and in the diagram. You can edit this label.
Description	
	<p>A text box where you can enter information describing or defining the project. Right-click text to open a shortcut menu. You can cut, copy, paste, and delete selected text within the Description text box. You can paste plain text from external applications.</p> <p>You can undo any action and you can select all text by pressing Ctrl+A.</p> <p>The following formatting options are available for the text: Bold, Italics, Underscore, and Strikethrough. You can also change the font color as well as the background color.</p>



Property View	Description
Notes	
	<p>A text box where you can annotate the element with additional information. Right-click text to open a shortcut menu. You can cut, copy, paste, and delete selected text within the Notes text box. You can paste plain text from external applications.</p> <p>You can undo any action and you can select all text by pressing Ctrl+A.</p> <p>The following formatting options are available for the text: Bold, Italics, Underscore, and Strikethrough. You can also change the font color as well as the background color</p>
Business Attributes	
	This tab contains a table displaying all the Business Attributes, Domains, and/or Business Elements contained in a Business Entity.
Name	Displays the name of the business attribute.
Unique Identifier	Adds a “#” indicator to the Business Attribute, Domain, or Business Element. This designates the attribute as a unique attribute which is mapped to Keys in an ER logical model.
Data Type	Click in this cell and all available data types are listed. The Data Types available are high level: binary, BLOB/Image, boolean, char, CLOB/Large Text, Decimal, Date, Integer, Time Stamp, Varchar, and XML.
Optionality	Click in this cell and drop-down list opens with three options: None, Mandatory, and Other. If you select Mandatory it becomes a mandatory property and a plus sign (+) appears to the left of the attribute. Select Optional and a minus sign (-) appears to the left of the attribute. Select None and no optionality setting appears.
Bound Business Element	Click in this cell and the drop-down list displays all Business Elements available for <a href="#">binding</a> . Note that the Business Attribute’s name changes to the newly selected Business Element.
Bound Domain	Click in this cell and the drop-down list displays all Domains available for <a href="#">binding</a> . Note that the Business Attribute’s name changes to the newly selected Domain.
Create Business Attribute	Click  to add a new Business Attribute to the Business Entity.
Edit Business Attribute	Click  to open the Property View for the selected Business Attribute.
Delete Business Attribute	Delete the selected attributed.
Move Business Attribute Up	You can reorder the attributes. Use the up arrow key to move the selected Business Attribute up.
Move Business Attribute Down	You can reorder the attributes. Use the down arrow key to move the selected Business Attribute down.

Property View	Description
Links	
Add Link	Opens the <a href="#">Create Link</a> wizard. This wizard allows you to create conceptual or usage links between elements.
Edit Link	Opens the property view for the selected link.
Delete Link	Deletes the selected link (either the link or the link target).
Show Selected Links on Active Diagram	Once you have created a link in the Diagram View, click this icon to display the links for the selected object in the diagram.
Expand All	Expands all the nodes in the tree.
Collapse All	Collapses all the nodes in the tree.
Refresh Links	Updates all the nodes in the Link Report.
Usage (CRUD)	
Usage	<p>The header displays the name of the linked element and the status of the filter (on or off).</p> <p>Receivers: Displays a list of the elements with usages (receivers). You can select multiple receivers in this list and delete all the receivers that are selected.</p> <p>Usage: Displays the usage setting (C, R, U, D). You can change the Usage attributes in this column and this change is reflected in the diagram. For example, you can change a C (Create) type to a U (Update) type.</p> <p>Usage Description: Displays the information entered in the Description text field for the target object of the usage. For example, if a usage was drawn between a task and a Data Store object, the description of the Data Store object is displayed.</p> <p>If there are no links or all the links have been filtered out, you are given the information that "No usages have been defined for this element" in the Receivers column.</p>
<a href="#">Add Usage</a>	Opens the Create Usage wizard where you can create a new usage.
<a href="#">Edit Usage</a>	When you select a Receiver in the table, the edit option becomes available. Click this to open the Usage edit tab where you can edit the name of the usage. The default name is "Usage". You can also change the usage settings (Create, Read, Update, and Delete). 
Delete	When you select a Receiver in the table, the delete option becomes available. This action removes the selected receiver from the usage. 
Show Selected Usages	When you select a Receiver in the table, the Show Selected Usages option (  ) becomes available. Click this icon to display the usage for the selected receiver in the diagram, including the usage settings.
Filter Receiver Types	Opens the Usage Report Filter dialog where you can select the types of objects you want included in the Usage Report.
<a href="#">Export Usage Report</a>	You can export the Usage (CRUD) reports in the following formats: CSV, HTML, PDF, and RTF

Property View	Description
<a href="#">Print</a>	Opens the Print dialog where you can select a printer, set preferences, select a page range and number of copies and then print.
Refresh Usage	Updates all the nodes in the Usage Report.
Impact Analysis	
Filter Designation	<p>Indicates whether a <a href="#">Filter</a> has been set for the Impact Analysis Report.</p> <p>Two icons are displayed to the left of the Filter Designation indicator:</p> <p>Click  to display the impact analysis information in a tree format.</p> <p>Click  to display the impact analysis information in a table format.</p>
<a href="#">Create Impact Analysis Diagram</a>	Once you create a link you can create a diagram that is a graphical representation of that link.
<a href="#">Filter</a>	Opens the Impact Analysis Filter dialog
Export	You can export and save the Impact Analysis report in the following file formats: CSV, HTML, PDF, and RTF.
Print	Opens the Print dialog where you can select a printer, set preferences, select a page range and number of copies and then print.
Expand All	Expands all the nodes in the tree.
Collapse All	Collapses all the nodes in the tree.
Refresh	Updates all the nodes in the Impact Analysis Report.
Appearance	
<a href="#">Font and Color Options</a>	Use these commands to change fonts and element colors.
<a href="#">Rendering</a>	Use these commands to change the shadowing and gradient settings for an element.
<a href="#">Horizontal Alignment</a>	Use these commands to set the justification for text labels in an element.
<a href="#">Vertical Alignment</a>	Use these commands to place the text in the top, center, or bottom of an element.
Diagram Display Options	<p>Show name: Displays the label of the Business Entity object. This option is selected by default.</p> <p>Show Expander Control: You can hide or show the expander indicator located in the lower right-hand corner of the object. The expander is shown as the default setting.</p>
Line Display Options	Select the width of the border from the drop-down list. You can select from 1 to 5 pixels.

Property View	Description
Business Attribute Diagram Display Options	<p>Show Business Attributes: Displays any Business Attributes in the Business Entity.</p> <p>Align attributes to top: When you place a business attribute in a Business Entity object, it is aligned in the top left corner of that object. If this option is not selected, the Business Attributes align in the bottom left corner of the object.</p> <p>Show Optionality: You can choose to hide or display the mandatory indicators (plus or minus) for the Business Attribute.</p> <p>Show Unique Identifier: Displays the unique identifier (#) to the left of the Business Attribute in a Business Entity.</p>
Apply to Diagram	Applies the formatting changes to all existing start events on the active diagram.
Restore Defaults	Restores the default settings for all changes made in the Appearance tab.
Set as Default	All formatting changes made in the Appearance tab become the default settings for new start event elements placed in the Diagram View.



## Business Attribute



The table below describes the Property View fields available for a Business Attribute:

Property View	Description
General	
Name	Name of the Business Attribute.
Unique Identifier	<p>Adds a “#” indicator to the business attribute. This designates the attribute as a unique attribute which is mapped to Keys in an ER logical model. This option is not selected by default.</p> <p>When this option is selected it is automatically mandatory so the Optionality setting is disabled.</p>
Data Type	The data types available are: Binary, BLOB/Image, Boolean, Char, CLOB/Large Text, Date, Decimal, Integer, None, Time Stamp, Varchar, and XML.
Width	The length of the attribute/domain datatype.
Scale	Indicates the number of digits after a decimal (for those data types that imply a decimal).
Optionality	<p>None: No optionality is to be set.</p> <p>Mandatory: If you select Mandatory it becomes a mandatory property and a plus sign (+) appears to the left of the attribute.</p> <p>Optional: If it is optional, a minus sign (-) appears to the left of the attribute.</p> <p><b>Note:</b> If the Unique Identifier option is selected, the Optionality property is automatically set to Mandatory and is disabled.</p>

Property View	Description
Business Element Binding Options	<p>Bound Business Element: Select the name of the Business Element <a href="#">binding</a> to the attribute from the drop-down list.</p> <p>Bound Business Element Domain: Click  and the Property View for the bound business element opens. This option is not available if the business attribute is not bound to a business element.</p> <p>Override the following properties of the business element: Select the property(ies) you want overridden in the bound business element. If the attribute is bound to a business element, the four check boxes are enabled and are synchronized with the business element properties.</p>
Domain Binding Options	<p>Bound Domain: Select the name of the domain from the drop-down list displaying all domains in the Reference Objects project.</p> <p>Override the following properties of the domain: Select the property(ies) you want overridden in the bound business domain. If the attribute is bound to a domain, the four check boxes are enabled and are synchronized with the domain properties. The override options are available only if the corresponding enforcement property is selected on the domain (i.e., the property is enforced). Otherwise, if you change the property on the attribute, it is assumed to be overriding the domain property.</p> <p><b>CAUTION:</b> You can bind to a Business Element or Domain, not to both. If you have a bound Business Element and attempt to also bind a domain, a Bound Domain Warning dialog opens. Select Yes to choose to remove the Business Element binding and bind the domain. If you select No the domain binding is not accepted and the Bound Domain selection returns to "None".</p>
Name	Name of the Business Attribute.
Description	
Override Bound Business Element Description	<p>If the Description Override option is selected on the General tab, this option is selected by default. This ensures that any description additions or changes are always in synch with the bound Business Element description.</p> <p>If this option is not selected, you cannot edit the description on this tab.</p> <p><b>CAUTION:</b> If you clear the override check box, the description from the Business Element is enforced on the Business Attribute without warning.</p>

Property View	Description
	<p>A text box where you can enter information describing or defining the project. Right-click text to open a shortcut menu. You can cut, copy, paste, and delete selected text within the Description text box. You can paste plain text from external applications.</p> <p>You can undo any action and you can select all text by pressing Ctrl+A.</p> <p>The following formatting options are available for the text: Bold, Italics, Underscore, and Strikethrough. You can also change the font color as well as the background color.</p>
Notes	
Override Bound Business Element Notes	<p>If the Notes Override option is selected on the General tab, this option is selected by default. This ensures that any notes additions or changes are always in synch with the bound Business Element notes.</p> <p>If this option is not selected, you cannot edit the notes on this tab.</p> <p><b>CAUTION:</b> If you clear the override check box, the notes from the Business Element is enforced on the Business Attribute without warning.</p>
	<p>A text box where you can annotate the element with additional information. Right-click text to open a shortcut menu. You can cut, copy, paste, and delete selected text within the Notes text box. You can paste plain text from external applications.</p> <p>You can undo any action and you can select all text by pressing Ctrl+A.</p> <p>The following formatting options are available for the text: Bold, Italics, Underscore, and Strikethrough. You can also change the font color as well as the background color</p>
Bindings	
Add Binding	<p>Opens the Create Binding with Targets... dialog where you can create <a href="#">bindings</a>.</p> <p><b>CAUTION:</b> You can bind to a Business Element or Domain, not to both. If you have a bound Business Element and attempt to also bind a domain, a Bound Domain Warning dialog opens. Select Yes to choose to remove the domain binding and bind the Business Element. If you select No the Business Element binding is not accepted and the Bound Business Element selection returns to "None".</p>
Edit Target	<p>Opens the Property View for the selected target in the Bindings hierarchy.</p>

Property View	Description
Delete Binding	Removes the source from the Bindings hierarchy.
Expand All	Expand the entire binding hierarchy.
Collapse All	Collapses the entire binding hierarchy.
Refresh Binding	Updates all the nodes in the Binding Report.
Resolve Violation	Resolves the conflict that occurs when a property is changed in a Business Attribute that doesn't match the property in a bound Business Element or Domain.
Links	
Add Link	Opens the <a href="#">Create Link</a> wizard. This wizard allows you to create conceptual or usage links between elements.
Edit Link	Opens the property view for the selected link.
Delete Link	Deletes the selected link (either the link or the link target).
Show Selected Links on Active Diagram	Once you have created a link in the Diagram View, click this icon to display the links for the selected object in the diagram.
Expand All	Expands all the nodes in the tree.
Collapse All	Collapses all the nodes in the tree.
Refresh Links	Updates all the nodes in the Link Report.
Usage (CRUD)	
Usage	<p>The header displays the name of the linked element and the status of the filter (on or off).</p> <p>Receivers: Displays a list of the elements with usages (receivers). You can select multiple receivers in this list and delete all the receivers that are selected.</p> <p>Usage: Displays the usage setting (C, R, U, D). You can change the Usage attributes in this column and this change is reflected in the diagram. For example, you can change a C (Create) type to a U (Update) type.</p> <p>Usage Description: Displays the information entered in the Description text field for the target object of the usage. For example, if a usage was drawn between a task and a Data Store object, the description of the Data Store object is displayed.</p> <p>If there are no links or all the links have been filtered out, you are given the information that "No usages have been defined for this element" in the Receivers column.</p>
<a href="#">Add Usage</a>	Opens the Create Usage wizard where you can create a new usage.
<a href="#">Edit Usage</a>	When you select a Receiver in the table, the edit option becomes available. Click this to open the Usage edit tab where you can edit the name of the usage. The default name is "Usage". You can also change the usage settings (Create, Read, Update, and Delete). 
Delete	When you select a Receiver in the table, the delete option becomes available. This action removes the selected receiver from the usage. 

Property View	Description
Show Selected Usages	When you select a Receiver in the table, the Show Selected Usages option (  ) becomes available. Click this icon to display the usage for the selected receiver in the diagram, including the usage settings.
Filter Receiver Types	Opens the Usage Report Filter dialog where you can select the types of objects you want included in the Usage Report.
<a href="#">Export Usage Report</a>	You can export the Usage (CRUD) reports in the following formats: CSV, HTML, PDF, and RTF
<a href="#">Print</a>	Opens the Print dialog where you can select a printer, set preferences, select a page range and number of copies and then print.
Refresh Usage	Updates all the nodes in the Usage Report.
Impact Analysis	
Filter Designation	Indicates whether a <a href="#">Filter</a> has been set for the Impact Analysis Report. Two icons are displayed to the left of the Filter Designation indicator:  Click  to display the impact analysis information in a tree format.  Click  to display the impact analysis information in a table format.
<a href="#">Create Impact Analysis Diagram</a>	Once you create a link you can create a diagram that is a graphical representation of that link.
<a href="#">Filter</a>	Opens the Impact Analysis Filter dialog
Export	You can export and save the Impact Analysis report in the following file formats: CSV, HTML, PDF, and RTF.
Print	Opens the Print dialog where you can select a printer, set preferences, select a page range and number of copies and then print.
Expand All	Expands all the nodes in the tree.
Collapse All	Collapses all the nodes in the tree.
Refresh	Updates all the nodes in the Impact Analysis Report.
Appearance	
<a href="#">Font and Color Options</a>	Use these commands to change fonts and element colors.
<a href="#">Horizontal Alignment</a>	Use these commands to set the justification for text labels in an element.
Diagram Display Options	You can choose to hide or show the unique identifier (#) for the Business Attribute. This option is selected by default when you have set an attribute as a unique identifier on the General tab.
Apply to Diagram	Applies the formatting changes to all existing start events on the active diagram.











Property View	Description
Restore Defaults	Restores the default settings for all changes made in the Appearance tab.
Set as Default	All formatting changes made in the Appearance tab become the default settings for new start event elements placed in the Diagram View.











## Interaction

The table below describes the Property View fields available for an Interaction:

Property View	Description
General	
Name	Label that appears for an element both in the Model View tree and in the diagram. You can edit this label.
Source	Displays the name of the source Business Element.
Target	Displays the name of the target Business Element.
Verb Phrase	Describes the parent-to-child action.
Inverse Verb Phrase	Describes the child-to-parent action.
Description	
	<p>A text box where you can enter information describing or defining the project. Right-click text to open a shortcut menu. You can cut, copy, paste, and delete selected text within the Description text box. You can paste plain text from external applications.</p> <p>You can undo any action and you can select all text by pressing Ctrl+A.</p> <p>The following formatting options are available for the text: Bold, Italics, Underscore, and Strikethrough. You can also change the font color as well as the background color.</p>
Notes	
	<p>A text box where you can annotate the element with additional information. Right-click text to open a shortcut menu. You can cut, copy, paste, and delete selected text within the Notes text box. You can paste plain text from external applications.</p> <p>You can undo any action and you can select all text by pressing Ctrl+A.</p> <p>The following formatting options are available for the text: Bold, Italics, Underscore, and Strikethrough. You can also change the font color as well as the background color.</p>

Property View	Description
Mappings	
Create Mapping	Click  to open the <a href="#">Create Mapping</a> dialog.
Edit Target	Click  to open the Property View for the targeted element.
Remove Target from Mapping	The deleted target is no longer mapped.
Links	
Add Link	Opens the <a href="#">Create Link</a> wizard. This wizard allows you to create conceptual or usage links between elements.
Edit Link	Opens the property view for the selected link.
Delete Link	Deletes the selected link (either the link or the link target).
Show Selected Links on Active Diagram	Once you have created a link in the Diagram View, click this icon to display the links for the selected object in the diagram.
Expand All	Expands all the nodes in the tree.
Collapse All	Collapses all the nodes in the tree.
Refresh Links	Updates all the nodes in the Link Report.
Usage (CRUD)	
Usage	<p>The header displays the name of the linked element and the status of the filter (on or off).</p> <p>Receivers: Displays a list of the elements with usages (receivers). You can select multiple receivers in this list and delete all the receivers that are selected.</p> <p>Usage: Displays the usage setting (C, R, U, D). You can change the Usage attributes in this column and this change is reflected in the diagram. For example, you can change a C (Create) type to a U (Update) type.</p> <p>Usage Description: Displays the information entered in the Description text field for the target object of the usage. For example, if a usage was drawn between a task and a Data Store object, the description of the Data Store object is displayed.</p> <p>If there are no links or all the links have been filtered out, you are given the information that "No usages have been defined for this element" in the Receivers column.</p>
<a href="#">Add Usage</a>	Opens the Create Usage wizard where you can create a new usage.
<a href="#">Edit Usage</a>	When you select a Receiver in the table, the edit option becomes available. Click this to open the Usage edit tab where you can edit the name of the usage. The default name is "Usage". You can also change the usage settings (Create, Read, Update, and Delete). 
Delete	When you select a Receiver in the table, the delete option becomes available. This action removes the selected receiver from the usage. 

Property View	Description
Show Selected Usages	When you select a Receiver in the table, the Show Selected Usages option (  ) becomes available. Click this icon to display the usage for the selected receiver in the diagram, including the usage settings.
Filter Receiver Types	Opens the Usage Report Filter dialog where you can select the types of objects you want included in the Usage Report.
<a href="#">Export Usage Report</a>	You can export the Usage (CRUD) reports in the following formats: CSV, HTML, PDF, and RTF
<a href="#">Print</a>	Opens the Print dialog where you can select a printer, set preferences, select a page range and number of copies and then print.
Refresh Usage	Updates all the nodes in the Usage Report.
Impact Analysis	
Filter Designation	Indicates whether a <a href="#">Filter</a> has been set for the Impact Analysis Report. Two icons are displayed to the left of the Filter Designation indicator:  <div style="display: flex; flex-direction: column; align-items: center;"> <div style="display: flex; align-items: center; margin-bottom: 10px;">  <span>Click  to display the impact analysis information in a tree format.</span> </div> <div style="display: flex; align-items: center;">  <span>Click  to display the impact analysis information in a table format.</span> </div> </div>
<a href="#">Create Impact Analysis Diagram</a>	Once you create a link you can create a diagram that is a graphical representation of that link.
<a href="#">Filter</a>	Opens the Impact Analysis Filter dialog
Export	You can export and save the Impact Analysis report in the following file formats: CSV, HTML, PDF, and RTF.
Print	Opens the Print dialog where you can select a printer, set preferences, select a page range and number of copies and then print.
Expand All	Expands all the nodes in the tree.
Collapse All	Collapses all the nodes in the tree.
Refresh	Updates all the nodes in the Impact Analysis Report.
Appearance	
<a href="#">Font and Color Options</a>	Use these commands to change fonts and element colors.
Diagram Display Options	Name: Displays the label of the Interaction. This option is selected by default. Verb Phrase: Displays the verb phrase text you entered on the General tab. Inverse Verb Phrase: Displays the inverse verb phrase text you entered on the General tab.



Property View	Description
Line Display Options	<p>Layout: You can select one of three layout styles: curved, elbowed, or straight. The default is curved.</p> <p>Line Width: You can change the width of the interaction in the diagram. Select 1 through 5 pixels from the drop-down list box.</p> <p>Line Style: You can select one of five different styles from the drop down list. The list includes solid, dash, dot, dash-dot, and dash-dot-dot.</p> <p>Source Decorator: Choose between five choices for the beginning of the Interaction link. Your choices are:</p> <ul style="list-style-type: none"> <li>•  none</li> <li>•  arrow</li> <li>•  diamond</li> <li>•  many to many</li> <li>•  triangle</li> </ul> <p>Source Decorator Size: Set the size of the decorator (arrow) at the origination point of the sequence flow. Your choices are: extra small (XS), small (S), medium (M), large (L), and extra large (XL).</p> <p>Target Decorator: Choose between five choices for the termination of the Interaction link. Your choices are:</p> <ul style="list-style-type: none"> <li>•  none</li> <li>•  arrow</li> <li>•  diamond</li> <li>•  many to many</li> <li>•  triangle</li> </ul> <p>Target Decorator Size: Set the size of the decorator (arrow) at the termination point of the sequence flow. Your choices are: extra small (XS), small (S), medium (M), large (L), and extra large (XL).</p>
Apply to Diagram	Applies the formatting changes to all existing start events on the active diagram.
Restore Defaults	Restores the default settings for all changes made in the Appearance tab.
Set as Default	All formatting changes made in the Appearance tab become the default settings for new start event elements placed in the Diagram View.





### Relationship











The table below describes the Property View fields available for a Relationship:

Property View	Description
General	
Name	Label that appears for an element both in the Model View tree and in the diagram. You can edit this label.
Source	Displays the name of the source Business Element.

Property View	Description
Target	Displays the name of the target Business Element.
Verb Phrase	Describes the parent-to-child action.
Inverse Verb Phrase	Describes the child-to-parent action.
Mandatory	If you select Mandatory it becomes a mandatory property and a plus sign (+) appears to the left of the attribute. If it is not mandatory, a minus sign (-) appears to the left of the attribute.
Relationship Type	Generic, Many to Many, Many to One, One to Many
Description	
	<p>A text box where you can enter information describing or defining the project. Right-click text to open a shortcut menu. You can cut, copy, paste, and delete selected text within the Description text box. You can paste plain text from external applications.</p> <p>You can undo any action and you can select all text by pressing Ctrl+A.</p> <p>The following formatting options are available for the text: Bold, Italics, Underscore, and Strikethrough. You can also change the font color as well as the background color.</p>
Notes	
	<p>A text box where you can annotate the element with additional information. Right-click text to open a shortcut menu. You can cut, copy, paste, and delete selected text within the Notes text box. You can paste plain text from external applications.</p> <p>You can undo any action and you can select all text by pressing Ctrl+A.</p> <p>The following formatting options are available for the text: Bold, Italics, Underscore, and Strikethrough. You can also change the font color as well as the background color.</p>
Links	
Add Link	Opens the <a href="#">Create Link</a> wizard. This wizard allows you to create conceptual or usage links between elements.
Edit Link	Opens the property view for the selected link.
Delete Link	Deletes the selected link (either the link or the link target).
Show Selected Links on Active Diagram	Once you have created a link in the Diagram View, click this icon to display the links for the selected object in the diagram.
Expand All	Expands all the nodes in the tree.
Collapse All	Collapses all the nodes in the tree.
Refresh Links	Updates all the nodes in the Link Report.

Property View	Description
Usage (CRUD)	
Usage	<p>The header displays the name of the linked element and the status of the filter (on or off).</p> <p>Receivers: Displays a list of the elements with usages (receivers). You can select multiple receivers in this list and delete all the receivers that are selected.</p> <p>Usage: Displays the usage setting (C, R, U, D). You can change the Usage attributes in this column and this change is reflected in the diagram. For example, you can change a C (Create) type to a U (Update) type.</p> <p>Usage Description: Displays the information entered in the Description text field for the target object of the usage. For example, if a usage was drawn between a task and a Data Store object, the description of the Data Store object is displayed.</p> <p>If there are no links or all the links have been filtered out, you are given the information that "No usages have been defined for this element" in the Receivers column.</p>
<a href="#">Add Usage</a>	Opens the Create Usage wizard where you can create a new usage.
<a href="#">Edit Usage</a>	<p>When you select a Receiver in the table, the edit option becomes available. Click this to open the Usage edit tab where you can edit the name of the usage. The default name is "Usage". You can also change the usage settings (Create, Read, Update, and Delete).</p> 
Delete	<p>When you select a Receiver in the table, the delete option becomes available. This action removes the selected receiver from the usage.</p> 
Show Selected Usages	<p>When you select a Receiver in the table, the Show Selected Usages option () becomes available. Click this icon to display the usage for the selected receiver in the diagram, including the usage settings.</p>
Filter Receiver Types	Opens the Usage Report Filter dialog where you can select the types of objects you want included in the Usage Report.
<a href="#">Export Usage Report</a>	You can export the Usage (CRUD) reports in the following formats: CSV, HTML, PDF, and RTF
<a href="#">Print</a>	Opens the Print dialog where you can select a printer, set preferences, select a page range and number of copies and then print.
Refresh Usage	Updates all the nodes in the Usage Report.

Property View	Description
Impact Analysis	
Filter Designation	<p>Indicates whether a <a href="#">Filter</a> has been set for the Impact Analysis Report.</p> <p>Two icons are displayed to the left of the Filter Designation indicator:</p> <p> Click  to display the impact analysis information in a tree format.</p> <p> Click  to display the impact analysis information in a table format.</p>
<a href="#">Create Impact Analysis Diagram</a>	Once you create a link you can create a diagram that is a graphical representation of that link.
<a href="#">Filter</a>	Opens the Impact Analysis Filter dialog
Export	You can export and save the Impact Analysis report in the following file formats: CSV, HTML, PDF, and RTF.
Print	Opens the Print dialog where you can select a printer, set preferences, select a page range and number of copies and then print.
Expand All	Expands all the nodes in the tree.
Collapse All	Collapses all the nodes in the tree.
Refresh	Updates all the nodes in the Impact Analysis Report.
Appearance	
<a href="#">Font and Color Options</a>	Use these commands to change fonts and element colors.
Diagram Display Options	<p>Show connection:</p> <p>Show Name: Displays the label of the Interaction. This option is selected by default.</p> <p>Show Verb Phrase: Displays the verb phrase text you entered on the General tab.</p> <p>Show Inverse Verb Phrase: Displays the inverse verb phrase text you entered on the General tab.</p> <p>Show Unique Identifier: Displays the identifier (   ) on the relationship.</p>

Property View	Description
Line Display Options	<p>Layout: You can select one of three layout styles: curved, elbowed, or straight. The default is curved.</p> <p>Line Width: You can change the width of the interaction in the diagram. Select 1 through 5 pixels from the drop-down list box.</p> <p>Line Style: You can select one of five different styles from the drop down list. The list includes solid, dash, dot, dash-dot, and dash-dot-dot.</p> <p>Source Decorator: Choose between five choices for the beginning of the Interaction link. Your choices are:</p> <ul style="list-style-type: none"> <li>•  none</li> <li>•  arrow</li> <li>•  diamond</li> <li>•  many to many</li> <li>•  triangle</li> </ul> <p>Source Decorator Size: Set the size of the decorator (arrow) at the origination point of the sequence flow. Your choices are: extra small (XS), small (S), medium (M), large (L), and extra large (XL).</p> <p>Target Decorator: Choose between five choices for the termination of the Interaction link. Your choices are:</p> <ul style="list-style-type: none"> <li>•  none</li> <li>•  arrow</li> <li>•  diamond</li> <li>•  many to many</li> <li>•  triangle</li> </ul> <p>Target Decorator Size: Set the size of the decorator (arrow) at the termination point of the sequence flow. Your choices are: extra small (XS), small (S), medium (M), large (L), and extra large (XL).</p>
Apply to Diagram	Applies the formatting changes to all existing start events on the active diagram.
Restore Defaults	Restores the default settings for all changes made in the Appearance tab.
Set as Default	All formatting changes made in the Appearance tab become the default settings for new start event elements placed in the Diagram View.

## General diagram elements

There are three general types of diagram elements available in ER/Studio BA: [Reference Objects](#), [External Data Objects](#), and [Drawing Shapes](#).



## Reference objects

There are four Reference Objects: [Business Elements](#), [Business Rules](#), [Business Units](#), [Domains](#), and [Stewards](#). Also, property views are available for the [Links](#) and [Usages](#) that you create between reference objects and processes and tasks.



### Business Elements





The table below describes the Property View fields available for Business Elements:

Property View	Description
General	
Name	Label that appears for an element both in the Model View tree and in the diagram. You can edit this label.
Data Type:	The data types available are: Binary, BLOB/Image, Boolean, Char, CLOB/Large Text, Date, Decimal, Integer, None, Timestamp, Varchar, and XML. The default setting is "None".
Enforcement options	<p>When you bind a Business Attribute to a Business Element, the attribute properties can be enforced (i.e., these properties replace the existing properties). The properties are: Name, Description, Notes, and Domain/Data Type. All items are selected by default.</p> <p>The enforced properties of Business Elements will always remain in synchronization with bound Business Attributes.</p> <p><b>CAUTION:</b> If you change the enforcement options on an existing Business Element with bound Business Attributes to allow overrides, the "override" controls are disabled for all existing and new Business Attributes bound to the Business Element.</p> <p>Also, if you have a Business Element without enforcement (which is bound to attributes) and you choose to start enforcing the Business Element's properties (i.e. the boxes are selected), a comparison is done on each of the bound Business Attributes to determine if the attribute's property matches the Business Element's property.</p> <ul style="list-style-type: none"> <li>• If the properties match, the "override" option is not selected on the attribute.</li> <li>• If the properties do not match, the "override" option is selected on the attribute. The override options are all enabled now that the properties are being enforced. In this manner, information is not lost on the Business Attribute. The information can be resolved at a later time from the properties view.</li> </ul>

Property View	Description
Description	
Override Bound Business Element Description	<p>If the Description Override option is selected on the General tab, this option is selected by default. This ensures that any description additions or changes are always in synch with the bound Business Element description.</p> <p>If this option is not selected, you cannot edit the description on this tab.</p> <p><b>CAUTION:</b> If you clear the override check box, the description from the Business Element is enforced on the Business Attribute without warning.</p>
	<p>A text box where you can enter information describing or defining the project. Right-click text to open a shortcut menu. You can cut, copy, paste, and delete selected text within the Description text box. You can paste plain text from external applications.</p> <p>You can undo any action and you can select all text by pressing Ctrl+A.</p> <p>The following formatting options are available for the text: Bold, Italics, Underscore, and Strikethrough. You can also change the font color as well as the background color.</p>
Notes	
Override Bound Business Element Notes	<p>If the Notes Override option is selected on the General tab, this option is selected by default. This ensures that any notes additions or changes are always in synch with the bound Business Element notes.</p> <p>If this option is not selected, you cannot edit the notes on this tab.</p> <p><b>CAUTION:</b> If you clear the override check box, the notes from the Business Element is enforced on the Business Attribute without warning.</p>
	<p>A text box where you can annotate the element with additional information. Right-click text to open a shortcut menu. You can cut, copy, paste, and delete selected text within the Notes text box. You can paste plain text from external applications.</p> <p>You can undo any action and you can select all text by pressing Ctrl+A.</p> <p>The following formatting options are available for the text: Bold, Italics, Underscore, and Strikethrough. You can also change the font color as well as the background color.</p>

Property View	Description
Bindings	
Add Binding	<p>Opens the Create Binding with Targets... dialog where you can create <a href="#">bindings</a>.</p> <p><b>CAUTION:</b> You can bind to a Business Element or Domain, not to both. If you have a bound Business Element and attempt to also bind a domain, a Bound Domain Warning dialog opens. Select Yes to choose to remove the domain binding and bind the Business Element. If you select No the Business Element binding is not accepted and the Bound Business Element selection returns to "None".</p>
Edit Target	Opens the Property View for the selected target in the Bindings hierarchy.
Delete Binding	Removes the source from the Bindings hierarchy.
Expand All	Expand the entire binding hierarchy.
Collapse All	Collapses the entire binding hierarchy.
Refresh Binding	Updates all the nodes in the Binding Report.
Resolve Violation	Resolves the conflict that occurs when a property is changed in a Business Attribute that doesn't match the property in a bound Business Element or Domain.
Links	
Add Link	Opens the <a href="#">Create Link</a> wizard. This wizard allows you to create conceptual or usage links between elements.
Edit Link	Opens the property view for the selected link.
Delete Link	Deletes the selected link (either the link or the link target).
Show Selected Links on Active Diagram	Once you have created a link in the Diagram View, click this icon to display the links for the selected object in the diagram.
Expand All	Expands all the nodes in the tree.
Collapse All	Collapses all the nodes in the tree.
Refresh Links	Updates all the nodes in the Link Report.



Property View	Description
Usage (CRUD)	
Usage	<p>The header displays the name of the linked element and the status of the filter (on or off).</p> <p>Receivers: Displays a list of the elements with usages (receivers). You can select multiple receivers in this list and delete all the receivers that are selected.</p> <p>Usage: Displays the usage setting (C, R, U, D). You can change the Usage attributes in this column and this change is reflected in the diagram. For example, you can change a C (Create) type to a U (Update) type.</p> <p>Usage Description: Displays the information entered in the Description text field for the target object of the usage. For example, if a usage was drawn between a task and a Data Store object, the description of the Data Store object is displayed.</p> <p>If there are no links or all the links have been filtered out, you are given the information that "No usages have been defined for this element" in the Receivers column.</p>
<a href="#">Add Usage</a>	Opens the Create Usage wizard where you can create a new usage.
<a href="#">Edit Usage</a>	<p>When you select a Receiver in the table, the edit option becomes available. Click this to open the Usage edit tab where you can edit the name of the usage. The default name is "Usage". You can also change the usage settings (Create, Read, Update, and Delete).</p> 
Delete	<p>When you select a Receiver in the table, the delete option becomes available. This action removes the selected receiver from the usage.</p> 
Show Selected Usages	<p>When you select a Receiver in the table, the Show Selected Usages option () becomes available. Click this icon to display the usage for the selected receiver in the diagram, including the usage settings.</p>
Filter Receiver Types	Opens the Usage Report Filter dialog where you can select the types of objects you want included in the Usage Report.
<a href="#">Export Usage Report</a>	You can export the Usage (CRUD) reports in the following formats: CSV, HTML, PDF, and RTF
<a href="#">Print</a>	Opens the Print dialog where you can select a printer, set preferences, select a page range and number of copies and then print.
Refresh Usage	Updates all the nodes in the Usage Report.





Property View	Description
Impact Analysis	
Filter Designation	<p>Indicates whether a <a href="#">Filter</a> has been set for the Impact Analysis Report.</p> <p>Two icons are displayed to the left of the Filter Designation indicator:</p> <p> Click  to display the impact analysis information in a tree format.</p> <p> Click  to display the impact analysis information in a table format.</p>
<a href="#">Create Impact Analysis Diagram</a>	Once you create a link you can create a diagram that is a graphical representation of that link.
<a href="#">Filter</a>	Opens the Impact Analysis Filter dialog
Export	You can export and save the Impact Analysis report in the following file formats: CSV, HTML, PDF, and RTF.
Print	Opens the Print dialog where you can select a printer, set preferences, select a page range and number of copies and then print.
Expand All	Expands all the nodes in the tree.
Collapse All	Collapses all the nodes in the tree.
Refresh	Updates all the nodes in the Impact Analysis Report.
Appearance	
<a href="#">Font and Color Options</a>	Use these commands to change fonts and element colors. Note that the element line and fill command is unavailable for the Business Rule element.
<a href="#">Horizontal Alignment</a>	Use these commands to set the justification for text labels in an element.
Diagram Display Options	Select this option to display the object's name.
Apply to Diagram	Applies the formatting changes to all existing shapes on the active diagram.
Restore Defaults	Restores the default settings for all changes made in the Appearance tab.
Set as Default	All formatting changes made in the Appearance tab become the default settings for new shapes placed in the Diagram View.

## Business Rules

A business rule is a policy, practice, or formula related to the operation and enforcement of business practices. The table below describes the Property View fields available for Business Rules:

Property View	Description
General	
Name	Label that appears for an element both in the Model View tree and in the diagram. You can edit this label.
Type:	<p>None: No type is required.</p> <p>Constraint: a condition that limits or controls the actions of the business.</p> <p>Definition: A statement that defines some aspect of the business.</p> <p>Derivation: A derivation is either a mathematical calculation or an inference.</p> <p>Fact: A fact is a set of named fields and typed values that encapsulates the binding information.</p>
Description	
	<p>A text box where you can enter information describing or defining the project. Right-click text to open a shortcut menu. You can cut, copy, paste, and delete selected text within the Description text box. You can paste plain text from external applications.</p> <p>You can undo any action and you can select all text by pressing Ctrl+A.</p> <p>The following formatting options are available for the text: Bold, Italics, Underscore, and Strikethrough. You can also change the font color as well as the background color.</p>
Notes	
	<p>A text box where you can annotate the element with additional information. Right-click text to open a shortcut menu. You can cut, copy, paste, and delete selected text within the Notes text box. You can paste plain text from external applications.</p> <p>You can undo any action and you can select all text by pressing Ctrl+A.</p> <p>The following formatting options are available for the text: Bold, Italics, Underscore, and Strikethrough. You can also change the font color as well as the background color.</p>
Links	
Add Link	Opens the <a href="#">Create Link</a> wizard. This wizard allows you to create conceptual or usage links between elements.
Edit Link	Opens the property view for the selected link.

Property View	Description
Delete Link	Deletes the selected link (either the link or the link target).
Show Selected Links on Active Diagram	Once you have created a link in the Diagram View, click this icon to display the links for the selected object in the diagram.
Expand All	Expands all the nodes in the tree.
Collapse All	Collapses all the nodes in the tree.
Refresh Links	Updates all the nodes in the Link Report.
Usage (CRUD)	
Usage	<p>The header displays the name of the linked element and the status of the filter (on or off).</p> <p>Receivers: Displays a list of the elements with usages (receivers). You can select multiple receivers in this list and delete all the receivers that are selected.</p> <p>Usage: Displays the usage setting (C, R, U, D). You can change the Usage attributes in this column and this change is reflected in the diagram. For example, you can change a C (Create) type to a U (Update) type.</p> <p>Usage Description: Displays the information entered in the Description text field for the target object of the usage. For example, if a usage was drawn between a task and a Data Store object, the description of the Data Store object is displayed.</p> <p>If there are no links or all the links have been filtered out, you are given the information that "No usages have been defined for this element" in the Receivers column.</p>
<a href="#">Add Usage</a>	Opens the Create Usage wizard where you can create a new usage.
<a href="#">Edit Usage</a>	When you select a Receiver in the table, the edit option becomes available. Click this to open the Usage edit tab where you can edit the name of the usage. The default name is "Usage". You can also change the usage settings (Create, Read, Update, and Delete). 
Delete	When you select a Receiver in the table, the delete option becomes available. This action removes the selected receiver from the usage. 
Show Selected Usages	When you select a Receiver in the table, the Show Selected Usages option (  ) becomes available. Click this icon to display the usage for the selected receiver in the diagram, including the usage settings.
Filter Receiver Types	Opens the Usage Report Filter dialog where you can select the types of objects you want included in the Usage Report.
<a href="#">Export Usage Report</a>	You can export the Usage (CRUD) reports in the following formats: CSV, HTML, PDF, and RTF
<a href="#">Print</a>	Opens the Print dialog where you can select a printer, set preferences, select a page range and number of copies and then print.
Refresh Usage	Updates all the nodes in the Usage Report.



Property View	Description
Impact Analysis	
Filter Designation	<p>Indicates whether a <a href="#">Filter</a> has been set for the Impact Analysis Report.</p> <p>Two icons are displayed to the left of the Filter Designation indicator:</p> <p> Click  to display the impact analysis information in a tree format.</p> <p> Click  to display the impact analysis information in a table format.</p>
<a href="#">Create Impact Analysis Diagram</a>	Once you create a link you can create a diagram that is a graphical representation of that link.
<a href="#">Filter</a>	Opens the Impact Analysis Filter dialog
Export	You can export and save the Impact Analysis report in the following file formats: CSV, HTML, PDF, and RTF.
Print	Opens the Print dialog where you can select a printer, set preferences, select a page range and number of copies and then print.
Expand All	Expands all the nodes in the tree.
Collapse All	Collapses all the nodes in the tree.
Refresh	Updates all the nodes in the Impact Analysis Report.
Appearance	
<a href="#">Font and Color Options</a>	Use these commands to change fonts and element colors. Note that the element line and fill command is unavailable for the Business Rule element.
<a href="#">Horizontal Alignment</a>	Use these commands to set the justification for text labels in an element.
Diagram Display Options	Select this option to display the object's name.
Apply to Diagram	Applies the formatting changes to all existing shapes on the active diagram.
Restore Defaults	Restores the default settings for all changes made in the Appearance tab.
Set as Default	All formatting changes made in the Appearance tab become the default settings for new shapes placed in the Diagram View.







## Business Units

A business unit is an organizational area within or external to an enterprise, for example, Human Resources, Sales, Accounting, etc. The table below describes the Property View fields available for Business Units:

Property View	Description
General	
Name:	Label that appears for an element both in the Model View tree and in the diagram. You can edit this label.
Description	
	<p>A text box where you can enter information describing or defining the project. Right-click text to open a shortcut menu. You can cut, copy, paste, and delete selected text within the Description text box. You can paste plain text from external applications.</p> <p>You can undo any action and you can select all text by pressing Ctrl+A.</p> <p>The following formatting options are available for the text: Bold, Italics, Underscore, and Strikethrough. You can also change the font color as well as the background color.</p>
Notes	
	<p>A text box where you can annotate the element with additional information. Right-click text to open a shortcut menu. You can cut, copy, paste, and delete selected text within the Notes text box. You can paste plain text from external applications.</p> <p>You can undo any action and you can select all text by pressing Ctrl+A.</p> <p>The following formatting options are available for the text: Bold, Italics, Underscore, and Strikethrough. You can also change the font color as well as the background color.</p>
Links	
Add Link	Opens the <a href="#">Create Link</a> wizard. This wizard allows you to create conceptual or usage links between elements.
Edit Link	Opens the property view for the selected link.
Delete Link	Deletes the selected link (either the link or the link target).
Show Selected Links on Active Diagram	Once you have created a link in the Diagram View, click this icon to display the links for the selected object in the diagram.
Expand All	Expands all the nodes in the tree.
Collapse All	Collapses all the nodes in the tree.
Refresh Links	Updates all the nodes in the Link Report.

Property View	Description
Usage (CRUD)	
Usage	<p>The header displays the name of the linked element and the status of the filter (on or off).</p> <p><b>Receivers:</b> Displays a list of the elements with usages (receivers). You can select multiple receivers in this list and delete all the receivers that are selected.</p> <p><b>Usage:</b> Displays the usage setting (C, R, U, D). You can change the Usage attributes in this column and this change is reflected in the diagram. For example, you can change a C (Create) type to a U (Update) type.</p> <p><b>Usage Description:</b> Displays the information entered in the Description text field for the target object of the usage. For example, if a usage was drawn between a task and a Data Store object, the description of the Data Store object is displayed.</p> <p>If there are no links or all the links have been filtered out, you are given the information that "No usages have been defined for this element" in the Receivers column.</p>
<a href="#">Add Usage</a>	Opens the Create Usage wizard where you can create a new usage.
<a href="#">Edit Usage</a>	<p>When you select a Receiver in the table, the edit option becomes available. Click this to open the Usage edit tab where you can edit the name of the usage. The default name is "Usage". You can also change the usage settings (Create, Read, Update, and Delete).</p> 
Delete	<p>When you select a Receiver in the table, the delete option becomes available. This action removes the selected receiver from the usage.</p> 
Show Selected Usages	<p>When you select a Receiver in the table, the Show Selected Usages option () becomes available. Click this icon to display the usage for the selected receiver in the diagram, including the usage settings.</p>
Filter Receiver Types	Opens the Usage Report Filter dialog where you can select the types of objects you want included in the Usage Report.
<a href="#">Export Usage Report</a>	You can export the Usage (CRUD) reports in the following formats: CSV, HTML, PDF, and RTF
<a href="#">Print</a>	Opens the Print dialog where you can select a printer, set preferences, select a page range and number of copies and then print.
Refresh Usage	Updates all the nodes in the Usage Report.





Property View	Description
Impact Analysis	
Filter Designation	<p>Indicates whether a <a href="#">Filter</a> has been set for the Impact Analysis Report.</p> <p>Two icons are displayed to the left of the Filter Designation indicator:</p> <p> Click  to display the impact analysis information in a tree format.</p> <p> Click  to display the impact analysis information in a table format.</p>
<a href="#">Create Impact Analysis Diagram</a>	Once you create a link you can create a diagram that is a graphical representation of that link.
<a href="#">Filter</a>	Opens the Impact Analysis Filter dialog
Export	You can export and save the Impact Analysis report in the following file formats: CSV, HTML, PDF, and RTF.
Print	Opens the Print dialog where you can select a printer, set preferences, select a page range and number of copies and then print.
Expand All	Expands all the nodes in the tree.
Collapse All	Collapses all the nodes in the tree.
Refresh	Updates all the nodes in the Impact Analysis Report.
Appearance	
<a href="#">Font and Color Options</a>	Use these commands to change fonts and element colors. Note that the element line and fill command is unavailable for the Business Rule element.
<a href="#">Horizontal Alignment</a>	Use these commands to set the justification for text labels in an element.
Diagram Display Options	Select this option to display the object's name.
Apply to Diagram	Applies the formatting changes to all existing shapes on the active diagram.
Restore Defaults	Restores the default settings for all changes made in the Appearance tab.
Set as Default	All formatting changes made in the Appearance tab become the default settings for new shapes placed in the Diagram View.

## Domains

Domains are reusable attribute templates that promote consistent domain definitions. You construct domains as you would attributes, specifying a name, datatype properties, null status, default values and validation rules. The table below describes the Property View fields available for Domains:

Property View	Description
General	
Name:	Label that appears for an element both in the Model View tree and in the diagram. You can edit this label.
Data Type:	The data types available are: Binary, BLOB/Image, Boolean, Char, CLOB/Large Text, Date, Decimal, Integer, None, Timestamp, Varchar, and XML. The default setting is Varchar.
Width	The length of the attribute/domain datatype.
Scale	Indicates the number of digits after a decimal (for those data types that imply a decimal).
Optionality	None Mandatory Optional The default value is "None"
Enforcement options	When binding to Business Attributes, the attribute properties can be enforced (i.e., these properties replace the existing properties). The properties are: Data Type, Width and Scale, and Optionality.
Description	
Override Bound Business Element Description	<p>If the Description Override option is selected on the General tab, this option is selected by default. This ensures that any description additions or changes are always in synch with the bound Business Element description.</p> <p>If this option is not selected, you cannot edit the description on this tab.</p> <p><b>CAUTION:</b> If you clear the override check box, the description from the Business Element is enforced on the Business Attribute without warning.</p>

Property View	Description
	<p>A text box where you can enter information describing or defining the project. Right-click text to open a shortcut menu. You can cut, copy, paste, and delete selected text within the Description text box. You can paste plain text from external applications.</p> <p>You can undo any action and you can select all text by pressing Ctrl+A.</p> <p>The following formatting options are available for the text: Bold, Italics, Underscore, and Strikethrough. You can also change the font color as well as the background color.</p>
Notes	
Override Bound Business Element Notes	<p>If the Notes Override option is selected on the General tab, this option is selected by default. This ensures that any notes additions or changes are always in synch with the bound Business Element notes.</p> <p>If this option is not selected, you cannot edit the notes on this tab.</p> <p><b>CAUTION:</b> If you clear the override check box, the notes from the Business Element is enforced on the Business Attribute without warning.</p>
	<p>A text box where you can annotate the element with additional information. Right-click text to open a shortcut menu. You can cut, copy, paste, and delete selected text within the Notes text box. You can paste plain text from external applications.</p> <p>You can undo any action and you can select all text by pressing Ctrl+A.</p> <p>The following formatting options are available for the text: Bold, Italics, Underscore, and Strikethrough. You can also change the font color as well as the background color.</p>
Bindings	
Add Binding	<p>Opens the Create Binding with Targets... dialog where you can create <a href="#">bindings</a>.</p> <p><b>CAUTION:</b> You can bind to a Business Element or Domain, not to both. If you have a bound Business Element and attempt to also bind a domain, a Bound Domain Warning dialog opens. Select Yes to choose to remove the domain binding and bind the Business Element. If you select No the Business Element binding is not accepted and the Bound Business Element selection returns to "None".</p>
Edit Target	<p>Opens the Property View for the selected target in the Bindings hierarchy.</p>



Property View	Description
Delete Binding	Removes the source from the Bindings hierarchy.
Expand All	Expand the entire binding hierarchy.
Collapse All	Collapses the entire binding hierarchy.
Refresh Binding	Updates all the nodes in the Binding Report.
Resolve Violation	Resolves the conflict that occurs when a property is changed in a Business Attribute that doesn't match the property in a bound Business Element or Domain.
Impact Analysis	
Filter Designation	<p>Indicates whether a <a href="#">Filter</a> has been set for the Impact Analysis Report.</p> <p>Two icons are displayed to the left of the Filter Designation indicator:</p> <p> Click  to display the impact analysis information in a tree format.</p> <p> Click  to display the impact analysis information in a table format.</p>
<a href="#">Create Impact Analysis Diagram</a>	Once you create a link you can create a diagram that is a graphical representation of that link.
<a href="#">Filter</a>	Opens the Impact Analysis Filter dialog
Export	You can export and save the Impact Analysis report in the following file formats: CSV, HTML, PDF, and RTF.
Print	Opens the Print dialog where you can select a printer, set preferences, select a page range and number of copies and then print.
Expand All	Expands all the nodes in the tree.
Collapse All	Collapses all the nodes in the tree.
Refresh	Updates all the nodes in the Impact Analysis Report.

## Stewards





A steward is a person or organization responsible or associated with a model element, for example "DBA, Auditor, Jeffrey Smith, etc." The table below describes the Property View fields available.:

Property View	Description
General	
Name:	Label that appears for an element both in the Model View tree and in the diagram. You can edit this label.
Type:	Does the steward represent an Individual or an organization?
E-mail Address:	If applicable, enter the e-mail address for the steward.
Responsibility:	If applicable, enter the responsibilities of the steward.

Property View	Description
Description	
	<p>A text box where you can enter information describing or defining the project. Right-click text to open a shortcut menu. You can cut, copy, paste, and delete selected text within the Description text box. You can paste plain text from external applications.</p> <p>You can undo any action and you can select all text by pressing Ctrl+A.</p> <p>The following formatting options are available for the text: Bold, Italics, Underscore, and Strikethrough. You can also change the font color as well as the background color.</p>
Notes	
	<p>A text box where you can annotate the element with additional information. Right-click text to open a shortcut menu. You can cut, copy, paste, and delete selected text within the Notes text box. You can paste plain text from external applications.</p> <p>You can undo any action and you can select all text by pressing Ctrl+A.</p> <p>The following formatting options are available for the text: Bold, Italics, Underscore, and Strikethrough. You can also change the font color as well as the background color.</p>
Links	
Add Link	Opens the <a href="#">Create Link</a> wizard. This wizard allows you to create conceptual or usage links between elements.
Edit Link	Opens the property view for the selected link.
Delete Link	Deletes the selected link (either the link or the link target).
Show Selected Links on Active Diagram	Once you have created a link in the Diagram View, click this icon to display the links for the selected object in the diagram.
Expand All	Expands all the nodes in the tree.
Collapse All	Collapses all the nodes in the tree.
Refresh Links	Updates all the nodes in the Link Report.





Property View	Description
Usage (CRUD)	
Usage	<p>The header displays the name of the linked element and the status of the filter (on or off).</p> <p>Receivers: Displays a list of the elements with usages (receivers). You can select multiple receivers in this list and delete all the receivers that are selected.</p> <p>Usage: Displays the usage setting (C, R, U, D). You can change the Usage attributes in this column and this change is reflected in the diagram. For example, you can change a C (Create) type to a U (Update) type.</p> <p>Usage Description: Displays the information entered in the Description text field for the target object of the usage. For example, if a usage was drawn between a task and a Data Store object, the description of the Data Store object is displayed.</p> <p>If there are no links or all the links have been filtered out, you are given the information that "No usages have been defined for this element" in the Receivers column.</p>
<a href="#">Add Usage</a>	Opens the Create Usage wizard where you can create a new usage.
<a href="#">Edit Usage</a>	<p>When you select a Receiver in the table, the edit option becomes available. Click this to open the Usage edit tab where you can edit the name of the usage. The default name is "Usage". You can also change the usage settings (Create, Read, Update, and Delete).</p> 
Delete	<p>When you select a Receiver in the table, the delete option becomes available. This action removes the selected receiver from the usage.</p> 
Show Selected Usages	<p>When you select a Receiver in the table, the Show Selected Usages option () becomes available. Click this icon to display the usage for the selected receiver in the diagram, including the usage settings.</p>
Filter Receiver Types	Opens the Usage Report Filter dialog where you can select the types of objects you want included in the Usage Report.
<a href="#">Export Usage Report</a>	You can export the Usage (CRUD) reports in the following formats: CSV, HTML, PDF, and RTF
<a href="#">Print</a>	Opens the Print dialog where you can select a printer, set preferences, select a page range and number of copies and then print.
Refresh Usage	Updates all the nodes in the Usage Report.







Property View	Description
Impact Analysis	
Filter Designation	<p>Indicates whether a <a href="#">Filter</a> has been set for the Impact Analysis Report.</p> <p>Two icons are displayed to the left of the Filter Designation indicator:</p> <p> Click  to display the impact analysis information in a tree format.</p> <p> Click  to display the impact analysis information in a table format.</p>
<a href="#">Create Impact Analysis Diagram</a>	Once you create a link you can create a diagram that is a graphical representation of that link.
<a href="#">Filter</a>	Opens the Impact Analysis Filter dialog
Export	You can export and save the Impact Analysis report in the following file formats: CSV, HTML, PDF, and RTF.
Print	Opens the Print dialog where you can select a printer, set preferences, select a page range and number of copies and then print.
Expand All	Expands all the nodes in the tree.
Collapse All	Collapses all the nodes in the tree.
Refresh	Updates all the nodes in the Impact Analysis Report.
Appearance	
<a href="#">Font and Color Options</a>	Use these commands to change fonts and element colors. Note that the element line and fill command is unavailable for the Business Rule element.
<a href="#">Horizontal Alignment</a>	Use these commands to set the justification for text labels in an element.
Diagram Display Options	Select this option to display the object's name.
Apply to Diagram	Applies the formatting changes to all existing shapes on the active diagram.
Restore Defaults	Restores the default settings for all changes made in the Appearance tab.
Set as Default	All formatting changes made in the Appearance tab become the default settings for new shapes placed in the Diagram View.

## Links

The table below describes the Property View fields available for the link:

Property View	Description
General	
Name	Label that appears for an element both in the Model View tree and in the diagram. You can edit this label.
Verb phrase	Type a verb phrase that describes the relationship from the perspective of the target. For example: EMPLOYEE "owns" RESUME. This label appears on the link where it connects to the linked element.
Inverse verb phrase	Type a verb phrase that describes the relationship from the perspective of the element to be linked to. For example: RESUME "is owned by" EMPLOYEE. This label appears on the link where it connects to the originating element.
Description	
	<p>A text box where you can enter information describing or defining the project. Right-click text to open a shortcut menu. You can cut, copy, paste, and delete selected text within the Description text box. You can paste plain text from external applications.</p> <p>You can undo any action and you can select all text by pressing Ctrl+A.</p> <p>The following formatting options are available for the text: Bold, Italics, Underscore, and Strikethrough. You can also change the font color as well as the background color.</p>
Notes	
	<p>A text box where you can annotate the element with additional information. Right-click text to open a shortcut menu. You can cut, copy, paste, and delete selected text within the Notes text box. You can paste plain text from external applications.</p> <p>You can undo any action and you can select all text by pressing Ctrl+A.</p> <p>The following formatting options are available for the text: Bold, Italics, Underscore, and Strikethrough. You can also change the font color as well as the background color.</p>
Source and Receivers	
Source	Click  to display the properties for the Link source.
Targets	A grid shows the Name and Element Type for the targets. You can add a link (  ) , edit the properties of a link (  ) , or delete a link (  ).





Property View	Description
Impact Analysis	
Filter Designation	<p>Indicates whether a <a href="#">Filter</a> has been set for the Impact Analysis Report.</p> <p>Two icons are displayed to the left of the Filter Designation indicator:</p> <p> Click  to display the impact analysis information in a tree format.</p> <p> Click  to display the impact analysis information in a table format.</p>
<a href="#">Create Impact Analysis Diagram</a>	Once you create a link you can create a diagram that is a graphical representation of that link.
<a href="#">Filter</a>	Opens the Impact Analysis Filter dialog
Export	You can export and save the Impact Analysis report in the following file formats: CSV, HTML, PDF, and RTF.
Print	Opens the Print dialog where you can select a printer, set preferences, select a page range and number of copies and then print.
Expand All	Expands all the nodes in the tree.
Collapse All	Collapses all the nodes in the tree.
Refresh	Updates all the nodes in the Impact Analysis Report.
Appearance	
<a href="#">Font and Color Options</a>	Use these commands to change fonts and element colors. Note that the element line and fill command is unavailable for the Business Rule element.
Diagram Display Options	<p>Show Connection: Selection this option to display the link in the diagram.</p> <p>Show Name: Select this option to display the label that appears for an element in the diagram.</p> <p>Show Inverse Verb Phrase: Displays the inverse verb phrase that describes the relationship from the perspective of the element to be linked to.</p> <p>Show Verb Phrase: Displays the verb phrase that describes the relationship from the perspective of the target.</p>
Line Display Options	<p>Layout: You can select one of three layout styles: curved, elbowed, or straight. The default is curved.</p> <p>Line Width: Select the width of the border from the drop-down list. You can select from 1 to 5 pixels.</p>
Apply to Diagram	Applies the formatting changes to all existing shapes on the active diagram.
Restore Defaults	Restores the default settings for all changes made in the Appearance tab.











Property View	Description
Set as Default	All formatting changes made in the Appearance tab become the default settings for new shapes placed in the Diagram View.

### Usages

The table below describes the Property View fields available for the Usage link:

Property View	Description
General	
Name	Label that appears for an element both in the Model View tree and in the diagram. You can edit this label.
Usage	Create: Add new records or entries. Read: View existing records or entries. Update: Edit existing records or entries. Delete: Eliminate existing records or entries.
Description	
	<p>A text box where you can enter information describing or defining the project. Right-click text to open a shortcut menu. You can cut, copy, paste, and delete selected text within the Description text box. You can paste plain text from external applications.</p> <p>You can undo any action and you can select all text by pressing Ctrl+A.</p> <p>The following formatting options are available for the text: Bold, Italics, Underscore, and Strikethrough. You can also change the font color as well as the background color.</p>
Notes	
	<p>A text box where you can annotate the element with additional information. Right-click text to open a shortcut menu. You can cut, copy, paste, and delete selected text within the Notes text box. You can paste plain text from external applications.</p> <p>You can undo any action and you can select all text by pressing Ctrl+A.</p> <p>The following formatting options are available for the text: Bold, Italics, Underscore, and Strikethrough. You can also change the font color as well as the background color.</p>

Property View	Description
Impact Analysis	
Filter Designation	<p>Indicates whether a <a href="#">Filter</a> has been set for the Impact Analysis Report.</p> <p>Two icons are displayed to the left of the Filter Designation indicator:</p> <p> Click  to display the impact analysis information in a tree format.</p> <p> Click  to display the impact analysis information in a table format.</p>
<a href="#">Create Impact Analysis Diagram</a>	Once you create a link you can create a diagram that is a graphical representation of that link.
<a href="#">Filter</a>	Opens the Impact Analysis Filter dialog
Export	You can export and save the Impact Analysis report in the following file formats: CSV, HTML, PDF, and RTF.
Print	Opens the Print dialog where you can select a printer, set preferences, select a page range and number of copies and then print.
Expand All	Expands all the nodes in the tree.
Collapse All	Collapses all the nodes in the tree.
Refresh	Updates all the nodes in the Impact Analysis Report.
Appearance	
<a href="#">Font and Color Options</a>	Use these commands to change fonts and element colors. Note that the element line and fill command is unavailable for the Business Rule element.
<a href="#">Horizontal Alignment</a>	Use these commands to set the justification for text labels in an element.
Diagram Display Options	<p>Show Connection: Select this option to display the Usage element.</p> <p>Show Name: Select this option to display the label that appears for an element in the diagram.</p> <p>Show Usage: Select this option to display the usage setting for the Usage.</p>

Property View	Description
Line Display Options	<p>Layout: You can select one of three layout styles: curved, elbowed, or straight. The default is curved.</p> <p>Line Width: You can change the width of the interaction in the diagram. Select 1 through 5 pixels from the drop-down list box.</p> <p>Line Style: You can select one of five different styles from the drop down list. The list includes solid, dash, dot, dash-dot, and dash-dot-dot.</p> <p>Source Decorator: Choose between five choices for the beginning of the Interaction link. Your choices are:</p> <ul style="list-style-type: none"> <li>•  none</li> <li>•  arrow</li> <li>•  diamond</li> <li>•  many to many</li> <li>•  triangle</li> </ul> <p>Source Decorator Size: Set the size of the decorator (arrow) at the origination point of the sequence flow. Your choices are: extra small (XS), small (S), medium (M), large (L), and extra large (XL).</p> <p>Target Decorator: Choose between five choices for the termination of the Interaction link. Your choices are:</p> <ul style="list-style-type: none"> <li>•  none</li> <li>•  arrow</li> <li>•  diamond</li> <li>•  many to many</li> <li>•  triangle</li> </ul> <p>Target Decorator Size: Set the size of the decorator (arrow) at the termination point of the sequence flow. Your choices are: extra small (XS), small (S), medium (M), large (L), and extra large (XL).</p>
Apply to Diagram	Applies the formatting changes to all existing shapes on the active diagram.
Restore Defaults	Restores the default settings for all changes made in the Appearance tab.
Set as Default	All formatting changes made in the Appearance tab become the default settings for new shapes placed in the Diagram View.

## External data objects

There are eight different external data objects: [Data Feed Object](#), [Data Store Object](#), [Entity Object](#), [Flat File Object](#), [Report Object](#), [Table Object](#) and [View Object](#). There are also associated Individual Elements: [Attribute](#), [Column](#), and [Data Element](#).

The table below describes the Property View fields available for an External Business Objects project:

Property View	Description
General	
Name	Label that appears for an element both in the Model View tree and in the diagram. You can edit this label.
Location	Displays the path and file name for the selected reference object.
Version	Displays the version of ER/Studio BA.
Model Type	Displays whether it is a Conceptual or Business Process model.
Model Type	
Description	
	<p>A text box where you can enter information describing or defining the project. Right-click text to open a shortcut menu. You can cut, copy, paste, and delete selected text within the Description text box. You can paste plain text from external applications.</p> <p>You can undo any action and you can select all text by pressing Ctrl+A.</p> <p>The following formatting options are available for the text: Bold, Italics, Underscore, and Strikethrough. You can also change the font color as well as the background color.</p>
Notes	
	<p>A text box where you can annotate the element with additional information. Right-click text to open a shortcut menu. You can cut, copy, paste, and delete selected text within the Notes text box. You can paste plain text from external applications.</p> <p>You can undo any action and you can select all text by pressing Ctrl+A.</p> <p>The following formatting options are available for the text: Bold, Italics, Underscore, and Strikethrough. You can also change the font color as well as the background color.</p>



### Data Feed Object





The table below describes the Property View fields available for the Data Feed Object:

Property View	Description
General	
Name	Label that appears for an element both in the Model View tree and in the diagram. You can edit this label.

Property View	Description
Location:	Displays the path and file name for the selected reference object.
Type	Type of data being transferred.
Description	
	<p>A text box where you can enter information describing or defining the project. Right-click text to open a shortcut menu. You can cut, copy, paste, and delete selected text within the Description text box. You can paste plain text from external applications.</p> <p>You can undo any action and you can select all text by pressing Ctrl+A.</p> <p>The following formatting options are available for the text: Bold, Italics, Underscore, and Strikethrough. You can also change the font color as well as the background color.</p>
Notes	
	<p>A text box where you can annotate the element with additional information. Right-click text to open a shortcut menu. You can cut, copy, paste, and delete selected text within the Notes text box. You can paste plain text from external applications.</p> <p>You can undo any action and you can select all text by pressing Ctrl+A.</p> <p>The following formatting options are available for the text: Bold, Italics, Underscore, and Strikethrough. You can also change the font color as well as the background color.</p>
Data Elements	
Name	Label that appears for an element both in the Model View tree and in the diagram. You can edit this label.
Links	
Add Link	Opens the <a href="#">Create Link</a> wizard. This wizard allows you to create conceptual or usage links between elements.
Edit Link	Opens the property view for the selected link.
Delete Link	Deletes the selected link (either the link or the link target).
Show Selected Links on Active Diagram	Once you have created a link in the Diagram View, click this icon to display the links for the selected object in the diagram.
Expand All	Expands all the nodes in the tree.
Collapse All	Collapses all the nodes in the tree.
Refresh Links	Updates all the nodes in the Link Report.





Property View	Description
Usage (CRUD)	
Usage	<p>The header displays the name of the linked element and the status of the filter (on or off).</p> <p>Receivers: Displays a list of the elements with usages (receivers). You can select multiple receivers in this list and delete all the receivers that are selected.</p> <p>Usage: Displays the usage setting (C, R, U, D). You can change the Usage attributes in this column and this change is reflected in the diagram. For example, you can change a C (Create) type to a U (Update) type.</p> <p>Usage Description: Displays the information entered in the Description text field for the target object of the usage. For example, if a usage was drawn between a task and a Data Store object, the description of the Data Store object is displayed.</p> <p>If there are no links or all the links have been filtered out, you are given the information that "No usages have been defined for this element" in the Receivers column.</p>
<a href="#">Add Usage</a>	Opens the Create Usage wizard where you can create a new usage.
<a href="#">Edit Usage</a>	<p>When you select a Receiver in the table, the edit option becomes available. Click this to open the Usage edit tab where you can edit the name of the usage. The default name is "Usage". You can also change the usage settings (Create, Read, Update, and Delete).</p> 
Delete	<p>When you select a Receiver in the table, the delete option becomes available. This action removes the selected receiver from the usage.</p> 
Show Selected Usages	<p>When you select a Receiver in the table, the Show Selected Usages option () becomes available. Click this icon to display the usage for the selected receiver in the diagram, including the usage settings.</p>
Filter Receiver Types	Opens the Usage Report Filter dialog where you can select the types of objects you want included in the Usage Report.
<a href="#">Export Usage Report</a>	You can export the Usage (CRUD) reports in the following formats: CSV, HTML, PDF, and RTF
<a href="#">Print</a>	Opens the Print dialog where you can select a printer, set preferences, select a page range and number of copies and then print.
Refresh Usage	Updates all the nodes in the Usage Report.





Property View	Description
Impact Analysis	
Filter Designation	<p>Indicates whether a <a href="#">Filter</a> has been set for the Impact Analysis Report.</p> <p>Two icons are displayed to the left of the Filter Designation indicator:</p> <p> Click  to display the impact analysis information in a tree format.</p> <p> Click  to display the impact analysis information in a table format.</p>
<a href="#">Create Impact Analysis Diagram</a>	Once you create a link you can create a diagram that is a graphical representation of that link.
<a href="#">Filter</a>	Opens the Impact Analysis Filter dialog
Export	You can export and save the Impact Analysis report in the following file formats: CSV, HTML, PDF, and RTF.
Print	Opens the Print dialog where you can select a printer, set preferences, select a page range and number of copies and then print.
Expand All	Expands all the nodes in the tree.
Collapse All	Collapses all the nodes in the tree.
Refresh	Updates all the nodes in the Impact Analysis Report.
Appearance	
<a href="#">Font and Color Options</a>	Use these commands to change fonts and element colors. Note that the element line and fill command is unavailable for the Business Rule element.
<a href="#">Horizontal Alignment</a>	Use these commands to set the justification for text labels in an element.
Diagram Display Options	Select this option to display the object's name.
Apply to Diagram	Applies the formatting changes to all existing shapes on the active diagram.
Restore Defaults	Restores the default settings for all changes made in the Appearance tab.
Set as Default	All formatting changes made in the Appearance tab become the default settings for new shapes placed in the Diagram View.

## Data Store Object

The table below describes the Property View fields available for the Data Store Object:

Property View	Description
General	
Name	Label that appears for an element both in the Model View tree and in the diagram. You can edit this label.
Location:	Displays the path and file name for the selected reference object.
Description	
	<p>A text box where you can enter information describing or defining the project. Right-click text to open a shortcut menu. You can cut, copy, paste, and delete selected text within the Description text box. You can paste plain text from external applications.</p> <p>You can undo any action and you can select all text by pressing Ctrl+A.</p> <p>The following formatting options are available for the text: Bold, Italics, Underscore, and Strikethrough. You can also change the font color as well as the background color.</p>
Notes	
	<p>A text box where you can annotate the element with additional information. Right-click text to open a shortcut menu. You can cut, copy, paste, and delete selected text within the Notes text box. You can paste plain text from external applications.</p> <p>You can undo any action and you can select all text by pressing Ctrl+A.</p> <p>The following formatting options are available for the text: Bold, Italics, Underscore, and Strikethrough. You can also change the font color as well as the background color.</p>
Data Elements	
Name	Label that appears for an element both in the Model View tree and in the diagram. You can edit this label.
Links	
Add Link	Opens the <a href="#">Create Link</a> wizard. This wizard allows you to create conceptual or usage links between elements.
Edit Link	Opens the property view for the selected link.
Delete Link	Deletes the selected link (either the link or the link target).
Show Selected Links on Active Diagram	Once you have created a link in the Diagram View, click this icon to display the links for the selected object in the diagram.
Expand All	Expands all the nodes in the tree.
Collapse All	Collapses all the nodes in the tree.



Property View	Description
Refresh Links	Updates all the nodes in the Link Report.
Usage (CRUD)	
Usage	<p>The header displays the name of the linked element and the status of the filter (on or off).</p> <p>Receivers: Displays a list of the elements with usages (receivers). You can select multiple receivers in this list and delete all the receivers that are selected.</p> <p>Usage: Displays the usage setting (C, R, U, D). You can change the Usage attributes in this column and this change is reflected in the diagram. For example, you can change a C (Create) type to a U (Update) type.</p> <p>Usage Description: Displays the information entered in the Description text field for the target object of the usage. For example, if a usage was drawn between a task and a Data Store object, the description of the Data Store object is displayed.</p> <p>If there are no links or all the links have been filtered out, you are given the information that "No usages have been defined for this element" in the Receivers column.</p>
<a href="#">Add Usage</a>	Opens the Create Usage wizard where you can create a new usage.
<a href="#">Edit Usage</a>	When you select a Receiver in the table, the edit option becomes available. Click this to open the Usage edit tab where you can edit the name of the usage. The default name is "Usage". You can also change the usage settings (Create, Read, Update, and Delete). 
Delete	When you select a Receiver in the table, the delete option becomes available. This action removes the selected receiver from the usage. 
Show Selected Usages	When you select a Receiver in the table, the Show Selected Usages option (  ) becomes available. Click this icon to display the usage for the selected receiver in the diagram, including the usage settings.
Filter Receiver Types	Opens the Usage Report Filter dialog where you can select the types of objects you want included in the Usage Report.
<a href="#">Export Usage Report</a>	You can export the Usage (CRUD) reports in the following formats: CSV, HTML, PDF, and RTF
<a href="#">Print</a>	Opens the Print dialog where you can select a printer, set preferences, select a page range and number of copies and then print.
Refresh Usage	Updates all the nodes in the Usage Report.



Property View	Description
Impact Analysis	
Filter Designation	<p>Indicates whether a <a href="#">Filter</a> has been set for the Impact Analysis Report.</p> <p>Two icons are displayed to the left of the Filter Designation indicator:</p> <p> Click  to display the impact analysis information in a tree format.</p> <p> Click  to display the impact analysis information in a table format.</p>
<a href="#">Create Impact Analysis Diagram</a>	Once you create a link you can create a diagram that is a graphical representation of that link.
<a href="#">Filter</a>	Opens the Impact Analysis Filter dialog
Export	You can export and save the Impact Analysis report in the following file formats: CSV, HTML, PDF, and RTF.
Print	Opens the Print dialog where you can select a printer, set preferences, select a page range and number of copies and then print.
Expand All	Expands all the nodes in the tree.
Collapse All	Collapses all the nodes in the tree.
Refresh	Updates all the nodes in the Impact Analysis Report.
Appearance	
<a href="#">Font and Color Options</a>	Use these commands to change fonts and element colors. Note that the element line and fill command is unavailable for the Business Rule element.
<a href="#">Horizontal Alignment</a>	Use these commands to set the justification for text labels in an element.
Diagram Display Options	Select this option to display the object's name.
Apply to Diagram	Applies the formatting changes to all existing shapes on the active diagram.
Restore Defaults	Restores the default settings for all changes made in the Appearance tab.
Set as Default	All formatting changes made in the Appearance tab become the default settings for new shapes placed in the Diagram View.

## Entity Object

The table below describes the Property View fields available for the Entity Object:

Property View	Description
General	
Name	Label that appears for an element both in the Model View tree and in the diagram. You can edit this label.
Description	
	<p>A text box where you can enter information describing or defining the project. Right-click text to open a shortcut menu. You can cut, copy, paste, and delete selected text within the Description text box. You can paste plain text from external applications.</p> <p>You can undo any action and you can select all text by pressing Ctrl+A.</p> <p>The following formatting options are available for the text: Bold, Italics, Underscore, and Strikethrough. You can also change the font color as well as the background color.</p>
Notes	
	<p>A text box where you can annotate the element with additional information. Right-click text to open a shortcut menu. You can cut, copy, paste, and delete selected text within the Notes text box. You can paste plain text from external applications.</p> <p>You can undo any action and you can select all text by pressing Ctrl+A.</p> <p>The following formatting options are available for the text: Bold, Italics, Underscore, and Strikethrough. You can also change the font color as well as the background color.</p>
Attributes	
Name	Default name is Attribute.
Data Type	Displays the data type for the Entity. Click in the cell and a drop-down list opens displaying all data type: Binary, Boolean, Char, Date, Decimal, Float, Integer, Long Binary, Money, Timestamp, Varchar, or XML
Width	The length of the attribute/domain datatype.
Scale	Indicates the number of digits after a decimal (for those data types that imply a decimal).
Nulls Allowed	Select Yes or No from the drop-down list to indicate whether nulls are allowed in the row.
Primary Key	Select Yes or No from the drop-down list to indicate whether the attribute is a primary key.

Property View	Description
Links	
Add Link	Opens the <a href="#">Create Link</a> wizard. This wizard allows you to create conceptual or usage links between elements.
Edit Link	Opens the property view for the selected link.
Delete Link	Deletes the selected link (either the link or the link target).
Show Selected Links on Active Diagram	Once you have created a link in the Diagram View, click this icon to display the links for the selected object in the diagram.
Expand All	Expands all the nodes in the tree.
Collapse All	Collapses all the nodes in the tree.
Refresh Links	Updates all the nodes in the Link Report.
Usage (CRUD)	
Usage	<p>The header displays the name of the linked element and the status of the filter (on or off).</p> <p>Receivers: Displays a list of the elements with usages (receivers). You can select multiple receivers in this list and delete all the receivers that are selected.</p> <p>Usage: Displays the usage setting (C, R, U, D). You can change the Usage attributes in this column and this change is reflected in the diagram. For example, you can change a C (Create) type to a U (Update) type.</p> <p>Usage Description: Displays the information entered in the Description text field for the target object of the usage. For example, if a usage was drawn between a task and a Data Store object, the description of the Data Store object is displayed.</p> <p>If there are no links or all the links have been filtered out, you are given the information that "No usages have been defined for this element" in the Receivers column.</p>
<a href="#">Add Usage</a>	Opens the Create Usage wizard where you can create a new usage.
<a href="#">Edit Usage</a>	When you select a Receiver in the table, the edit option becomes available. Click this to open the Usage edit tab where you can edit the name of the usage. The default name is "Usage". You can also change the usage settings (Create, Read, Update, and Delete). 
Delete	When you select a Receiver in the table, the delete option becomes available. This action removes the selected receiver from the usage. 
Show Selected Usages	When you select a Receiver in the table, the Show Selected Usages option (  ) becomes available. Click this icon to display the usage for the selected receiver in the diagram, including the usage settings.
Filter Receiver Types	Opens the Usage Report Filter dialog where you can select the types of objects you want included in the Usage Report.
<a href="#">Export Usage Report</a>	You can export the Usage (CRUD) reports in the following formats: CSV, HTML, PDF, and RTF



Property View	Description
<a href="#">Print</a>	Opens the Print dialog where you can select a printer, set preferences, select a page range and number of copies and then print.
Refresh Usage	Updates all the nodes in the Usage Report.
Impact Analysis	
Filter Designation	<p>Indicates whether a <a href="#">Filter</a> has been set for the Impact Analysis Report.</p> <p>Two icons are displayed to the left of the Filter Designation indicator:</p> <p>Click  to display the impact analysis information in a tree format.</p> <p>Click  to display the impact analysis information in a table format.</p>
<a href="#">Create Impact Analysis Diagram</a>	Once you create a link you can create a diagram that is a graphical representation of that link.
<a href="#">Filter</a>	Opens the Impact Analysis Filter dialog
Export	You can export and save the Impact Analysis report in the following file formats: CSV, HTML, PDF, and RTF.
Print	Opens the Print dialog where you can select a printer, set preferences, select a page range and number of copies and then print.
Expand All	Expands all the nodes in the tree.
Collapse All	Collapses all the nodes in the tree.
Refresh	Updates all the nodes in the Impact Analysis Report.
Appearance	
<a href="#">Font and Color Options</a>	Use these commands to change fonts and element colors. Note that the element line and fill command is unavailable for the Business Rule element.
<a href="#">Horizontal Alignment</a>	Use these commands to set the justification for text labels in an element.
Diagram Display Options	Select this option to display the object's name.
Apply to Diagram	Applies the formatting changes to all existing shapes on the active diagram.
Restore Defaults	Restores the default settings for all changes made in the Appearance tab.
Set as Default	All formatting changes made in the Appearance tab become the default settings for new shapes placed in the Diagram View.







## Flat File Object

The table below describes the Property View fields available for this Object:

Property View	Description
General	
Name	Label that appears for an element both in the Model View tree and in the diagram. You can edit this label.
Location:	Displays the path and file name for the selected reference object.
Description	
	<p>A text box where you can enter information describing or defining the project. Right-click text to open a shortcut menu. You can cut, copy, paste, and delete selected text within the Description text box. You can paste plain text from external applications.</p> <p>You can undo any action and you can select all text by pressing Ctrl+A.</p> <p>The following formatting options are available for the text: Bold, Italics, Underscore, and Strikethrough. You can also change the font color as well as the background color.</p>
Notes	
	<p>A text box where you can annotate the element with additional information. Right-click text to open a shortcut menu. You can cut, copy, paste, and delete selected text within the Notes text box. You can paste plain text from external applications.</p> <p>You can undo any action and you can select all text by pressing Ctrl+A.</p> <p>The following formatting options are available for the text: Bold, Italics, Underscore, and Strikethrough. You can also change the font color as well as the background color.</p>
Data Elements	
Name	Name of data element contained in the flat file. Default name is Data Element.
Links	
Add Link	Opens the <a href="#">Create Link</a> wizard. This wizard allows you to create conceptual or usage links between elements.
Edit Link	Opens the property view for the selected link.
Delete Link	Deletes the selected link (either the link or the link target).
Show Selected Links on Active Diagram	Once you have created a link in the Diagram View, click this icon to display the links for the selected object in the diagram.
Expand All	Expands all the nodes in the tree.
Collapse All	Collapses all the nodes in the tree.



Property View	Description
Refresh Links	Updates all the nodes in the Link Report.
Usage (CRUD)	
Usage	<p>The header displays the name of the linked element and the status of the filter (on or off).</p> <p>Receivers: Displays a list of the elements with usages (receivers). You can select multiple receivers in this list and delete all the receivers that are selected.</p> <p>Usage: Displays the usage setting (C, R, U, D). You can change the Usage attributes in this column and this change is reflected in the diagram. For example, you can change a C (Create) type to a U (Update) type.</p> <p>Usage Description: Displays the information entered in the Description text field for the target object of the usage. For example, if a usage was drawn between a task and a Data Store object, the description of the Data Store object is displayed.</p> <p>If there are no links or all the links have been filtered out, you are given the information that "No usages have been defined for this element" in the Receivers column.</p>
<a href="#">Add Usage</a>	Opens the Create Usage wizard where you can create a new usage.
<a href="#">Edit Usage</a>	When you select a Receiver in the table, the edit option becomes available. Click this to open the Usage edit tab where you can edit the name of the usage. The default name is "Usage". You can also change the usage settings (Create, Read, Update, and Delete). 
Delete	When you select a Receiver in the table, the delete option becomes available. This action removes the selected receiver from the usage. 
Show Selected Usages	When you select a Receiver in the table, the Show Selected Usages option (  ) becomes available. Click this icon to display the usage for the selected receiver in the diagram, including the usage settings.
Filter Receiver Types	Opens the Usage Report Filter dialog where you can select the types of objects you want included in the Usage Report.
<a href="#">Export Usage Report</a>	You can export the Usage (CRUD) reports in the following formats: CSV, HTML, PDF, and RTF
<a href="#">Print</a>	Opens the Print dialog where you can select a printer, set preferences, select a page range and number of copies and then print.
Refresh Usage	Updates all the nodes in the Usage Report.





Property View	Description
Impact Analysis	
Filter Designation	<p>Indicates whether a <a href="#">Filter</a> has been set for the Impact Analysis Report.</p> <p>Two icons are displayed to the left of the Filter Designation indicator:</p> <p> Click  to display the impact analysis information in a tree format.</p> <p> Click  to display the impact analysis information in a table format.</p>
<a href="#">Create Impact Analysis Diagram</a>	Once you create a link you can create a diagram that is a graphical representation of that link.
<a href="#">Filter</a>	Opens the Impact Analysis Filter dialog
Export	You can export and save the Impact Analysis report in the following file formats: CSV, HTML, PDF, and RTF.
Print	Opens the Print dialog where you can select a printer, set preferences, select a page range and number of copies and then print.
Expand All	Expands all the nodes in the tree.
Collapse All	Collapses all the nodes in the tree.
Refresh	Updates all the nodes in the Impact Analysis Report.
Appearance	
<a href="#">Font and Color Options</a>	Use these commands to change fonts and element colors. Note that the element line and fill command is unavailable for the Business Rule element.
<a href="#">Horizontal Alignment</a>	Use these commands to set the justification for text labels in an element.
Diagram Display Options	Select this option to display the object's name.
Apply to Diagram	Applies the formatting changes to all existing shapes on the active diagram.
Restore Defaults	Restores the default settings for all changes made in the Appearance tab.
Set as Default	All formatting changes made in the Appearance tab become the default settings for new shapes placed in the Diagram View.

## Report Object

The table below describes the Property View fields available for the Report Object:

Property View	Description
General	
Name	Label that appears for an element both in the Model View tree and in the diagram. You can edit this label.
Location:	Displays the path and file name for the selected reference object.
Type	Select a type of report from a drop-down list: Business Intelligence (BI) Report, Microsoft Word Document, or Microsoft Excel Spreadsheet.
Description	
	<p>A text box where you can enter information describing or defining the project. Right-click text to open a shortcut menu. You can cut, copy, paste, and delete selected text within the Description text box. You can paste plain text from external applications.</p> <p>You can undo any action and you can select all text by pressing Ctrl+A.</p> <p>The following formatting options are available for the text: Bold, Italics, Underscore, and Strikethrough. You can also change the font color as well as the background color.</p>
Notes	
	<p>A text box where you can annotate the element with additional information. Right-click text to open a shortcut menu. You can cut, copy, paste, and delete selected text within the Notes text box. You can paste plain text from external applications.</p> <p>You can undo any action and you can select all text by pressing Ctrl+A.</p> <p>The following formatting options are available for the text: Bold, Italics, Underscore, and Strikethrough. You can also change the font color as well as the background color.</p>
Data Elements	
Name	Name of data element contained in the flat file. Default name is Data Element.
Links	
Add Link	Opens the <a href="#">Create Link</a> wizard. This wizard allows you to create conceptual or usage links between elements.
Edit Link	Opens the property view for the selected link.
Delete Link	Deletes the selected link (either the link or the link target).

Property View	Description
Show Selected Links on Active Diagram	Once you have created a link in the Diagram View, click this icon to display the links for the selected object in the diagram.
Expand All	Expands all the nodes in the tree.
Collapse All	Collapses all the nodes in the tree.
Refresh Links	Updates all the nodes in the Link Report.
Usage (CRUD)	
Usage	<p>The header displays the name of the linked element and the status of the filter (on or off).</p> <p>Receivers: Displays a list of the elements with usages (receivers). You can select multiple receivers in this list and delete all the receivers that are selected.</p> <p>Usage: Displays the usage setting (C, R, U, D). You can change the Usage attributes in this column and this change is reflected in the diagram. For example, you can change a C (Create) type to a U (Update) type.</p> <p>Usage Description: Displays the information entered in the Description text field for the target object of the usage. For example, if a usage was drawn between a task and a Data Store object, the description of the Data Store object is displayed.</p> <p>If there are no links or all the links have been filtered out, you are given the information that "No usages have been defined for this element" in the Receivers column.</p>
<a href="#">Add Usage</a>	Opens the Create Usage wizard where you can create a new usage.
<a href="#">Edit Usage</a>	When you select a Receiver in the table, the edit option becomes available. Click this to open the Usage edit tab where you can edit the name of the usage. The default name is "Usage". You can also change the usage settings (Create, Read, Update, and Delete). 
Delete	When you select a Receiver in the table, the delete option becomes available. This action removes the selected receiver from the usage. 
Show Selected Usages	When you select a Receiver in the table, the Show Selected Usages option (  ) becomes available. Click this icon to display the usage for the selected receiver in the diagram, including the usage settings.
Filter Receiver Types	Opens the Usage Report Filter dialog where you can select the types of objects you want included in the Usage Report.
<a href="#">Export Usage Report</a>	You can export the Usage (CRUD) reports in the following formats: CSV, HTML, PDF, and RTF
<a href="#">Print</a>	Opens the Print dialog where you can select a printer, set preferences, select a page range and number of copies and then print.
Refresh Usage	Updates all the nodes in the Usage Report.



Property View	Description
Impact Analysis	
Filter Designation	<p>Indicates whether a <a href="#">Filter</a> has been set for the Impact Analysis Report.</p> <p>Two icons are displayed to the left of the Filter Designation indicator:</p> <p> Click  to display the impact analysis information in a tree format.</p> <p> Click  to display the impact analysis information in a table format.</p>
<a href="#">Create Impact Analysis Diagram</a>	Once you create a link you can create a diagram that is a graphical representation of that link.
<a href="#">Filter</a>	Opens the Impact Analysis Filter dialog
Export	You can export and save the Impact Analysis report in the following file formats: CSV, HTML, PDF, and RTF.
Print	Opens the Print dialog where you can select a printer, set preferences, select a page range and number of copies and then print.
Expand All	Expands all the nodes in the tree.
Collapse All	Collapses all the nodes in the tree.
Refresh	Updates all the nodes in the Impact Analysis Report.
Appearance	
<a href="#">Font and Color Options</a>	Use these commands to change fonts and element colors. Note that the element line and fill command is unavailable for the Business Rule element.
<a href="#">Horizontal Alignment</a>	Use these commands to set the justification for text labels in an element.
Diagram Display Options	Select this option to display the object's name.
Apply to Diagram	Applies the formatting changes to all existing shapes on the active diagram.
Restore Defaults	Restores the default settings for all changes made in the Appearance tab.
Set as Default	All formatting changes made in the Appearance tab become the default settings for new shapes placed in the Diagram View.

### Table Object





The table below describes the Property View fields available for the Table Object:

Property View	Description
General	

Property View	Description
Name	Label that appears for an element both in the Model View tree and in the diagram. You can edit this label.
Description	
	<p>A text box where you can enter information describing or defining the project. Right-click text to open a shortcut menu. You can cut, copy, paste, and delete selected text within the Description text box. You can paste plain text from external applications.</p> <p>You can undo any action and you can select all text by pressing Ctrl+A.</p> <p>The following formatting options are available for the text: Bold, Italics, Underscore, and Strikethrough. You can also change the font color as well as the background color.</p>
Notes	
	<p>A text box where you can annotate the element with additional information. Right-click text to open a shortcut menu. You can cut, copy, paste, and delete selected text within the Notes text box. You can paste plain text from external applications.</p> <p>You can undo any action and you can select all text by pressing Ctrl+A.</p> <p>The following formatting options are available for the text: Bold, Italics, Underscore, and Strikethrough. You can also change the font color as well as the background color.</p>
Columns	
Name	Default name is Column.
Data Type	Displays the data type for the Table. Click in the cell and a drop-down list opens displaying all data types: Binary, Boolean, Char, Date, Decimal, Float, Integer, Long Binary, Money, Timestamp, Varchar, or XML
Width	The length of the attribute/domain datatype.
Scale	Indicates the number of digits after a decimal (for those data types that imply a decimal).
Nulls Allowed	Select Yes or No from the drop-down list to indicate whether nulls are allowed in the row.
Primary Key	Select Yes or No from the drop-down list to indicate whether the attribute is a primary key.
Links	
Add Link	Opens the <a href="#">Create Link</a> wizard. This wizard allows you to create conceptual or usage links between elements.
Edit Link	Opens the property view for the selected link.
Delete Link	Deletes the selected link (either the link or the link target).

Property View	Description
Show Selected Links on Active Diagram	Once you have created a link in the Diagram View, click this icon to display the links for the selected object in the diagram.
Expand All	Expands all the nodes in the tree.
Collapse All	Collapses all the nodes in the tree.
Refresh Links	Updates all the nodes in the Link Report.
Usage (CRUD)	
Usage	<p>The header displays the name of the linked element and the status of the filter (on or off).</p> <p>Receivers: Displays a list of the elements with usages (receivers). You can select multiple receivers in this list and delete all the receivers that are selected.</p> <p>Usage: Displays the usage setting (C, R, U, D). You can change the Usage attributes in this column and this change is reflected in the diagram. For example, you can change a C (Create) type to a U (Update) type.</p> <p>Usage Description: Displays the information entered in the Description text field for the target object of the usage. For example, if a usage was drawn between a task and a Data Store object, the description of the Data Store object is displayed.</p> <p>If there are no links or all the links have been filtered out, you are given the information that "No usages have been defined for this element" in the Receivers column.</p>
<a href="#">Add Usage</a>	Opens the Create Usage wizard where you can create a new usage.
<a href="#">Edit Usage</a>	When you select a Receiver in the table, the edit option becomes available. Click this to open the Usage edit tab where you can edit the name of the usage. The default name is "Usage". You can also change the usage settings (Create, Read, Update, and Delete). 
Delete	When you select a Receiver in the table, the delete option becomes available. This action removes the selected receiver from the usage. 
Show Selected Usages	When you select a Receiver in the table, the Show Selected Usages option (  ) becomes available. Click this icon to display the usage for the selected receiver in the diagram, including the usage settings.
Filter Receiver Types	Opens the Usage Report Filter dialog where you can select the types of objects you want included in the Usage Report.
<a href="#">Export Usage Report</a>	You can export the Usage (CRUD) reports in the following formats: CSV, HTML, PDF, and RTF
<a href="#">Print</a>	Opens the Print dialog where you can select a printer, set preferences, select a page range and number of copies and then print.
Refresh Usage	Updates all the nodes in the Usage Report.







Property View	Description
Impact Analysis	
Filter Designation	<p>Indicates whether a <a href="#">Filter</a> has been set for the Impact Analysis Report.</p> <p>Two icons are displayed to the left of the Filter Designation indicator:</p> <p> Click  to display the impact analysis information in a tree format.</p> <p> Click  to display the impact analysis information in a table format.</p>
<a href="#">Create Impact Analysis Diagram</a>	Once you create a link you can create a diagram that is a graphical representation of that link.
<a href="#">Filter</a>	Opens the Impact Analysis Filter dialog
Export	You can export and save the Impact Analysis report in the following file formats: CSV, HTML, PDF, and RTF.
Print	Opens the Print dialog where you can select a printer, set preferences, select a page range and number of copies and then print.
Expand All	Expands all the nodes in the tree.
Collapse All	Collapses all the nodes in the tree.
Refresh	Updates all the nodes in the Impact Analysis Report.
Appearance	
<a href="#">Font and Color Options</a>	Use these commands to change fonts and element colors. Note that the element line and fill command is unavailable for the Business Rule element.
<a href="#">Horizontal Alignment</a>	Use these commands to set the justification for text labels in an element.
Diagram Display Options	Select this option to display the object's name.
Apply to Diagram	Applies the formatting changes to all existing shapes on the active diagram.
Restore Defaults	Restores the default settings for all changes made in the Appearance tab.
Set as Default	All formatting changes made in the Appearance tab become the default settings for new shapes placed in the Diagram View.

## View Object

The table below describes the Property View fields available for the View Object:

Property View	Description
General	
Name	Label that appears for an element both in the Model View tree and in the diagram. You can edit this label.
Description	
	<p>A text box where you can enter information describing or defining the project. Right-click text to open a shortcut menu. You can cut, copy, paste, and delete selected text within the Description text box. You can paste plain text from external applications.</p> <p>You can undo any action and you can select all text by pressing Ctrl+A.</p> <p>The following formatting options are available for the text: Bold, Italics, Underscore, and Strikethrough. You can also change the font color as well as the background color.</p>
Notes	
	<p>A text box where you can annotate the element with additional information. Right-click text to open a shortcut menu. You can cut, copy, paste, and delete selected text within the Notes text box. You can paste plain text from external applications.</p> <p>You can undo any action and you can select all text by pressing Ctrl+A.</p> <p>The following formatting options are available for the text: Bold, Italics, Underscore, and Strikethrough. You can also change the font color as well as the background color.</p>
Columns	
Name	Default name is Column.
Data Type	Displays the data type for the Table. Click in the cell and a drop-down list opens displaying all data types: Binary, Boolean, Char, Date, Decimal, Float, Integer, Long Binary, Money, Timestamp, Varchar, or XML
Width	The length of the attribute/domain datatype.
Scale	Indicates the number of digits after a decimal (for those data types that imply a decimal).
Nulls Allowed	Select Yes or No from the drop-down list to indicate whether nulls are allowed in the row.
Primary Key	Select Yes or No from the drop-down list to indicate whether the attribute is a primary key.



Property View	Description
Links	
Add Link	Opens the <a href="#">Create Link</a> wizard. This wizard allows you to create conceptual or usage links between elements.
Edit Link	Opens the property view for the selected link.
Delete Link	Deletes the selected link (either the link or the link target).
Show Selected Links on Active Diagram	Once you have created a link in the Diagram View, click this icon to display the links for the selected object in the diagram.
Expand All	Expands all the nodes in the tree.
Collapse All	Collapses all the nodes in the tree.
Refresh Links	Updates all the nodes in the Link Report.
Usage (CRUD)	
Usage	<p>The header displays the name of the linked element and the status of the filter (on or off).</p> <p>Receivers: Displays a list of the elements with usages (receivers). You can select multiple receivers in this list and delete all the receivers that are selected.</p> <p>Usage: Displays the usage setting (C, R, U, D). You can change the Usage attributes in this column and this change is reflected in the diagram. For example, you can change a C (Create) type to a U (Update) type.</p> <p>Usage Description: Displays the information entered in the Description text field for the target object of the usage. For example, if a usage was drawn between a task and a Data Store object, the description of the Data Store object is displayed.</p> <p>If there are no links or all the links have been filtered out, you are given the information that "No usages have been defined for this element" in the Receivers column.</p>
<a href="#">Add Usage</a>	Opens the Create Usage wizard where you can create a new usage.
<a href="#">Edit Usage</a>	When you select a Receiver in the table, the edit option becomes available. Click this to open the Usage edit tab where you can edit the name of the usage. The default name is "Usage". You can also change the usage settings (Create, Read, Update, and Delete). 
Delete	When you select a Receiver in the table, the delete option becomes available. This action removes the selected receiver from the usage. 
Show Selected Usages	When you select a Receiver in the table, the Show Selected Usages option (  ) becomes available. Click this icon to display the usage for the selected receiver in the diagram, including the usage settings.
Filter Receiver Types	Opens the Usage Report Filter dialog where you can select the types of objects you want included in the Usage Report.
<a href="#">Export Usage Report</a>	You can export the Usage (CRUD) reports in the following formats: CSV, HTML, PDF, and RTF





Property View	Description
<a href="#">Print</a>	Opens the Print dialog where you can select a printer, set preferences, select a page range and number of copies and then print.
Refresh Usage	Updates all the nodes in the Usage Report.
Impact Analysis	
Filter Designation	<p>Indicates whether a <a href="#">Filter</a> has been set for the Impact Analysis Report.</p> <p>Two icons are displayed to the left of the Filter Designation indicator:</p> <p>Click  to display the impact analysis information in a tree format.</p> <p>Click  to display the impact analysis information in a table format.</p>
<a href="#">Create Impact Analysis Diagram</a>	Once you create a link you can create a diagram that is a graphical representation of that link.
<a href="#">Filter</a>	Opens the Impact Analysis Filter dialog
Export	You can export and save the Impact Analysis report in the following file formats: CSV, HTML, PDF, and RTF.
Print	Opens the Print dialog where you can select a printer, set preferences, select a page range and number of copies and then print.
Expand All	Expands all the nodes in the tree.
Collapse All	Collapses all the nodes in the tree.
Refresh	Updates all the nodes in the Impact Analysis Report.
Appearance	
<a href="#">Font and Color Options</a>	Use these commands to change fonts and element colors. Note that the element line and fill command is unavailable for the Business Rule element.
<a href="#">Horizontal Alignment</a>	Use these commands to set the justification for text labels in an element.
Diagram Display Options	Select this option to display the object's name.
Apply to Diagram	Applies the formatting changes to all existing shapes on the active diagram.
Restore Defaults	Restores the default settings for all changes made in the Appearance tab.
Set as Default	All formatting changes made in the Appearance tab become the default settings for new shapes placed in the Diagram View.

## Attribute

The table below describes the Property View fields available for the Data Feed Object:

Property View	Description
General	
Name	Label that appears for an element both in the Model View tree and in the diagram. You can edit this label.
Data Type	Click in this cell and all available data types are listed. The Data Types available are high level: binary, BLOB/Image, boolean, char, CLOB/Large Text, Decimal, Date, Integer, Time Stamp, Varchar, and XML.
Width	The length of the attribute/domain datatype.
Scale	Indicates the number of digits after a decimal (for those data types that imply a decimal).
Allow Nulls	Specifies whether or no nulls are possible.
Primary Key	Select Yes or No from the drop-down list to indicate whether the attribute is a primary key.
Description	
	<p>A text box where you can enter information describing or defining the project. Right-click text to open a shortcut menu. You can cut, copy, paste, and delete selected text within the Description text box. You can paste plain text from external applications.</p> <p>You can undo any action and you can select all text by pressing Ctrl+A.</p> <p>The following formatting options are available for the text: Bold, Italics, Underscore, and Strikethrough. You can also change the font color as well as the background color.</p>
Notes	
	<p>A text box where you can annotate the element with additional information. Right-click text to open a shortcut menu. You can cut, copy, paste, and delete selected text within the Notes text box. You can paste plain text from external applications.</p> <p>You can undo any action and you can select all text by pressing Ctrl+A.</p> <p>The following formatting options are available for the text: Bold, Italics, Underscore, and Strikethrough. You can also change the font color as well as the background color.</p>
Links	
Add Link	Opens the <a href="#">Create Link</a> wizard. This wizard allows you to create conceptual or usage links between elements.
Edit Link	Opens the property view for the selected link.

Property View	Description
Delete Link	Deletes the selected link (either the link or the link target).
Show Selected Links on Active Diagram	Once you have created a link in the Diagram View, click this icon to display the links for the selected object in the diagram.
Expand All	Expands all the nodes in the tree.
Collapse All	Collapses all the nodes in the tree.
Refresh Links	Updates all the nodes in the Link Report.
Usage (CRUD)	
Usage	<p>The header displays the name of the linked element and the status of the filter (on or off).</p> <p>Receivers: Displays a list of the elements with usages (receivers). You can select multiple receivers in this list and delete all the receivers that are selected.</p> <p>Usage: Displays the usage setting (C, R, U, D). You can change the Usage attributes in this column and this change is reflected in the diagram. For example, you can change a C (Create) type to a U (Update) type.</p> <p>Usage Description: Displays the information entered in the Description text field for the target object of the usage. For example, if a usage was drawn between a task and a Data Store object, the description of the Data Store object is displayed.</p> <p>If there are no links or all the links have been filtered out, you are given the information that "No usages have been defined for this element" in the Receivers column.</p>
<a href="#">Add Usage</a>	Opens the Create Usage wizard where you can create a new usage.
<a href="#">Edit Usage</a>	When you select a Receiver in the table, the edit option becomes available. Click this to open the Usage edit tab where you can edit the name of the usage. The default name is "Usage". You can also change the usage settings (Create, Read, Update, and Delete). 
Delete	When you select a Receiver in the table, the delete option becomes available. This action removes the selected receiver from the usage. 
Show Selected Usages	When you select a Receiver in the table, the Show Selected Usages option (  ) becomes available. Click this icon to display the usage for the selected receiver in the diagram, including the usage settings.
Filter Receiver Types	Opens the Usage Report Filter dialog where you can select the types of objects you want included in the Usage Report.
<a href="#">Export Usage Report</a>	You can export the Usage (CRUD) reports in the following formats: CSV, HTML, PDF, and RTF
<a href="#">Print</a>	Opens the Print dialog where you can select a printer, set preferences, select a page range and number of copies and then print.
Refresh Usage	Updates all the nodes in the Usage Report.

Property View	Description
Impact Analysis	
Filter Designation	<p>Indicates whether a <a href="#">Filter</a> has been set for the Impact Analysis Report.</p> <p>Two icons are displayed to the left of the Filter Designation indicator:</p> <p> Click  to display the impact analysis information in a tree format.</p> <p> Click  to display the impact analysis information in a table format.</p>
<a href="#">Create Impact Analysis Diagram</a>	Once you create a link you can create a diagram that is a graphical representation of that link.
<a href="#">Filter</a>	Opens the Impact Analysis Filter dialog
Export	You can export and save the Impact Analysis report in the following file formats: CSV, HTML, PDF, and RTF.
Print	Opens the Print dialog where you can select a printer, set preferences, select a page range and number of copies and then print.
Expand All	Expands all the nodes in the tree.
Collapse All	Collapses all the nodes in the tree.
Refresh	Updates all the nodes in the Impact Analysis Report.
Appearance	
<a href="#">Font and Color Options</a>	Use these commands to change fonts and element colors. Note that the element line and fill command is unavailable for the Business Rule element.
<a href="#">Horizontal Alignment</a>	Use these commands to set the justification for text labels in an element.
Diagram Display Options	Select this option to display the object's name.
Apply to Diagram	Applies the formatting changes to all existing shapes on the active diagram.
Restore Defaults	Restores the default settings for all changes made in the Appearance tab.
Set as Default	All formatting changes made in the Appearance tab become the default settings for new shapes placed in the Diagram View.



## Column





The table below describes the Property View fields available for the Data Feed Object:

Property View	Description
General	

Property View	Description
Name	Label that appears for an element both in the Model View tree and in the diagram. You can edit this label.
Data Type	Click in this cell and all available data types are listed. The Data Types available are high level: binary, BLOB/Image, boolean, char, CLOB/Large Text, Decimal, Date, Integer, Time Stamp, Varchar, and XML.
Width	The length of the attribute/domain datatype.
Scale	Indicates the number of digits after a decimal (for those data types that imply a decimal).
Allow Nulls	Specifies whether or no nulls are possible.
Primary Key	Select Yes or No from the drop-down list to indicate whether the attribute is a primary key.
Description	
	<p>A text box where you can enter information describing or defining the project. Right-click text to open a shortcut menu. You can cut, copy, paste, and delete selected text within the Description text box. You can paste plain text from external applications.</p> <p>You can undo any action and you can select all text by pressing Ctrl+A.</p> <p>The following formatting options are available for the text: Bold, Italics, Underscore, and Strikethrough. You can also change the font color as well as the background color.</p>
Notes	
	<p>A text box where you can annotate the element with additional information. Right-click text to open a shortcut menu. You can cut, copy, paste, and delete selected text within the Notes text box. You can paste plain text from external applications.</p> <p>You can undo any action and you can select all text by pressing Ctrl+A.</p> <p>The following formatting options are available for the text: Bold, Italics, Underscore, and Strikethrough. You can also change the font color as well as the background color.</p>
Links	
Add Link	Opens the <a href="#">Create Link</a> wizard. This wizard allows you to create conceptual or usage links between elements.
Edit Link	Opens the property view for the selected link.
Delete Link	Deletes the selected link (either the link or the link target).
Show Selected Links on Active Diagram	Once you have created a link in the Diagram View, click this icon to display the links for the selected object in the diagram.
Expand All	Expands all the nodes in the tree.





Property View	Description
Collapse All	Collapses all the nodes in the tree.
Refresh Links	Updates all the nodes in the Link Report.
Usage (CRUD)	
Usage	<p>The header displays the name of the linked element and the status of the filter (on or off).</p> <p>Receivers: Displays a list of the elements with usages (receivers). You can select multiple receivers in this list and delete all the receivers that are selected.</p> <p>Usage: Displays the usage setting (C, R, U, D). You can change the Usage attributes in this column and this change is reflected in the diagram. For example, you can change a C (Create) type to a U (Update) type.</p> <p>Usage Description: Displays the information entered in the Description text field for the target object of the usage. For example, if a usage was drawn between a task and a Data Store object, the description of the Data Store object is displayed.</p> <p>If there are no links or all the links have been filtered out, you are given the information that "No usages have been defined for this element" in the Receivers column.</p>
<a href="#">Add Usage</a>	Opens the Create Usage wizard where you can create a new usage.
<a href="#">Edit Usage</a>	When you select a Receiver in the table, the edit option becomes available. Click this to open the Usage edit tab where you can edit the name of the usage. The default name is "Usage". You can also change the usage settings (Create, Read, Update, and Delete). 
Delete	When you select a Receiver in the table, the delete option becomes available. This action removes the selected receiver from the usage. 
Show Selected Usages	When you select a Receiver in the table, the Show Selected Usages option (  ) becomes available. Click this icon to display the usage for the selected receiver in the diagram, including the usage settings.
Filter Receiver Types	Opens the Usage Report Filter dialog where you can select the types of objects you want included in the Usage Report.
<a href="#">Export Usage Report</a>	You can export the Usage (CRUD) reports in the following formats: CSV, HTML, PDF, and RTF
<a href="#">Print</a>	Opens the Print dialog where you can select a printer, set preferences, select a page range and number of copies and then print.
Refresh Usage	Updates all the nodes in the Usage Report.





Property View	Description
Impact Analysis	
Filter Designation	<p>Indicates whether a <a href="#">Filter</a> has been set for the Impact Analysis Report.</p> <p>Two icons are displayed to the left of the Filter Designation indicator:</p> <p> Click  to display the impact analysis information in a tree format.</p> <p> Click  to display the impact analysis information in a table format.</p>
<a href="#">Create Impact Analysis Diagram</a>	Once you create a link you can create a diagram that is a graphical representation of that link.
<a href="#">Filter</a>	Opens the Impact Analysis Filter dialog
Export	You can export and save the Impact Analysis report in the following file formats: CSV, HTML, PDF, and RTF.
Print	Opens the Print dialog where you can select a printer, set preferences, select a page range and number of copies and then print.
Expand All	Expands all the nodes in the tree.
Collapse All	Collapses all the nodes in the tree.
Refresh	Updates all the nodes in the Impact Analysis Report.
Appearance	
<a href="#">Font and Color Options</a>	Use these commands to change fonts and element colors. Note that the element line and fill command is unavailable for the Business Rule element.
<a href="#">Horizontal Alignment</a>	Use these commands to set the justification for text labels in an element.
Diagram Display Options	Select this option to display the object's name.
Apply to Diagram	Applies the formatting changes to all existing shapes on the active diagram.
Restore Defaults	Restores the default settings for all changes made in the Appearance tab.
Set as Default	All formatting changes made in the Appearance tab become the default settings for new shapes placed in the Diagram View.

## Data Element

The table below describes the Property View fields available for the Data Feed Object:

Property View	Description
General	
Name	Label that appears for an element both in the Model View tree and in the diagram. You can edit this label.
Description	
	<p>A text box where you can enter information describing or defining the project. Right-click text to open a shortcut menu. You can cut, copy, paste, and delete selected text within the Description text box. You can paste plain text from external applications.</p> <p>You can undo any action and you can select all text by pressing Ctrl+A.</p> <p>The following formatting options are available for the text: Bold, Italics, Underscore, and Strikethrough. You can also change the font color as well as the background color.</p>
Notes	
	<p>A text box where you can annotate the element with additional information. Right-click text to open a shortcut menu. You can cut, copy, paste, and delete selected text within the Notes text box. You can paste plain text from external applications.</p> <p>You can undo any action and you can select all text by pressing Ctrl+A.</p> <p>The following formatting options are available for the text: Bold, Italics, Underscore, and Strikethrough. You can also change the font color as well as the background color.</p>
Links	
Add Link	Opens the <a href="#">Create Link</a> wizard. This wizard allows you to create conceptual or usage links between elements.
Edit Link	Opens the property view for the selected link.
Delete Link	Deletes the selected link (either the link or the link target).
Show Selected Links on Active Diagram	Once you have created a link in the Diagram View, click this icon to display the links for the selected object in the diagram.
Expand All	Expands all the nodes in the tree.
Collapse All	Collapses all the nodes in the tree.
Refresh Links	Updates all the nodes in the Link Report.

Property View	Description
Usage (CRUD)	
Usage	<p>The header displays the name of the linked element and the status of the filter (on or off).</p> <p>Receivers: Displays a list of the elements with usages (receivers). You can select multiple receivers in this list and delete all the receivers that are selected.</p> <p>Usage: Displays the usage setting (C, R, U, D). You can change the Usage attributes in this column and this change is reflected in the diagram. For example, you can change a C (Create) type to a U (Update) type.</p> <p>Usage Description: Displays the information entered in the Description text field for the target object of the usage. For example, if a usage was drawn between a task and a Data Store object, the description of the Data Store object is displayed.</p> <p>If there are no links or all the links have been filtered out, you are given the information that "No usages have been defined for this element" in the Receivers column.</p>
<a href="#">Add Usage</a>	Opens the Create Usage wizard where you can create a new usage.
<a href="#">Edit Usage</a>	<p>When you select a Receiver in the table, the edit option becomes available. Click this to open the Usage edit tab where you can edit the name of the usage. The default name is "Usage". You can also change the usage settings (Create, Read, Update, and Delete).</p> 
Delete	<p>When you select a Receiver in the table, the delete option becomes available. This action removes the selected receiver from the usage.</p> 
Show Selected Usages	<p>When you select a Receiver in the table, the Show Selected Usages option () becomes available. Click this icon to display the usage for the selected receiver in the diagram, including the usage settings.</p>
Filter Receiver Types	Opens the Usage Report Filter dialog where you can select the types of objects you want included in the Usage Report.
<a href="#">Export Usage Report</a>	You can export the Usage (CRUD) reports in the following formats: CSV, HTML, PDF, and RTF
<a href="#">Print</a>	Opens the Print dialog where you can select a printer, set preferences, select a page range and number of copies and then print.
Refresh Usage	Updates all the nodes in the Usage Report.



Property View	Description
Impact Analysis	
Filter Designation	<p>Indicates whether a <a href="#">Filter</a> has been set for the Impact Analysis Report.</p> <p>Two icons are displayed to the left of the Filter Designation indicator:</p> <p> Click  to display the impact analysis information in a tree format.</p> <p> Click  to display the impact analysis information in a table format.</p>
<a href="#">Create Impact Analysis Diagram</a>	Once you create a link you can create a diagram that is a graphical representation of that link.
<a href="#">Filter</a>	Opens the Impact Analysis Filter dialog
Export	You can export and save the Impact Analysis report in the following file formats: CSV, HTML, PDF, and RTF.
Print	Opens the Print dialog where you can select a printer, set preferences, select a page range and number of copies and then print.
Expand All	Expands all the nodes in the tree.
Collapse All	Collapses all the nodes in the tree.
Refresh	Updates all the nodes in the Impact Analysis Report.
Appearance	
<a href="#">Font and Color Options</a>	Use these commands to change fonts and element colors. Note that the element line and fill command is unavailable for the Business Rule element.
<a href="#">Horizontal Alignment</a>	Use these commands to set the justification for text labels in an element.
Diagram Display Options	Select this option to display the object's name.
Apply to Diagram	Applies the formatting changes to all existing shapes on the active diagram.
Restore Defaults	Restores the default settings for all changes made in the Appearance tab.
Set as Default	All formatting changes made in the Appearance tab become the default settings for new shapes placed in the Diagram View.





## Drawing shapes

Drawing Shapes are used to provide additional information about the Process. There are nine different shapes: Box, Rounded Box, Circle, Triangle, Diamond, Pentagon, Hexagon, Octagon, Cylinder, and Text Label. The properties are the same for all the shapes with the exception of the [Text Label](#), [Line](#), and [Annotation](#).

The table below describes the Property View fields available for all the drawing shapes:

Property View	Description
General	
Name	Label that appears for an element both in the Model View tree and in the diagram. You can edit this label.
Type:	Displays the type of shape, i.e., Octagon.
Description	
	<p>A text box where you can enter information describing or defining the project. Right-click text to open a shortcut menu. You can cut, copy, paste, and delete selected text within the Description text box. You can paste plain text from external applications.</p> <p>You can undo any action and you can select all text by pressing Ctrl+A.</p> <p>The following formatting options are available for the text: Bold, Italics, Underscore, and Strikethrough. You can also change the font color as well as the background color.</p>
Notes	
	<p>A text box where you can annotate the element with additional information. Right-click text to open a shortcut menu. You can cut, copy, paste, and delete selected text within the Notes text box. You can paste plain text from external applications.</p> <p>You can undo any action and you can select all text by pressing Ctrl+A.</p> <p>The following formatting options are available for the text: Bold, Italics, Underscore, and Strikethrough. You can also change the font color as well as the background color.</p>
Links	
Add Link	Opens the <a href="#">Create Link</a> wizard. This wizard allows you to create conceptual or usage links between elements.
Edit Link	Opens the property view for the selected link.
Delete Link	Deletes the selected link (either the link or the link target).
Show Selected Links on Active Diagram	Once you have created a link in the Diagram View, click this icon to display the links for the selected object in the diagram.
Expand All	Expands all the nodes in the tree.

Property View	Description
<a href="#">Collapse All</a>	Collapses all the nodes in the tree.
<a href="#">Refresh Links</a>	Updates all the nodes in the Link Report.
Usage (CRUD)	
Usage	<p>The header displays the name of the linked element and the status of the filter (on or off).</p> <p>Receivers: Displays a list of the elements with usages (receivers). You can select multiple receivers in this list and delete all the receivers that are selected.</p> <p>Usage: Displays the usage setting (C, R, U, D). You can change the Usage attributes in this column and this change is reflected in the diagram. For example, you can change a C (Create) type to a U (Update) type.</p> <p>Usage Description: Displays the information entered in the Description text field for the target object of the usage. For example, if a usage was drawn between a task and a Data Store object, the description of the Data Store object is displayed.</p> <p>If there are no links or all the links have been filtered out, you are given the information that "No usages have been defined for this element" in the Receivers column.</p>
<a href="#">Add Usage</a>	Opens the Create Usage wizard where you can create a new usage.
<a href="#">Edit Usage</a>	When you select a Receiver in the table, the edit option becomes available. Click this to open the Usage edit tab where you can edit the name of the usage. The default name is "Usage". You can also change the usage settings (Create, Read, Update, and Delete). 
Delete	When you select a Receiver in the table, the delete option (  ) becomes available. This action removes the selected receiver from the usage.
Show Selected Usages	When you select a Receiver in the table, the Show Selected Usages option (  ) becomes available. Click this icon to display the usage for the selected receiver in the diagram, including the usage settings.
Filter Receiver Types	Opens the Usage Report Filter dialog where you can select the types of objects you want included in the Usage Report.
<a href="#">Export Usage Report</a>	You can export the Usage (CRUD) reports in the following formats: CSV, HTML, PDF, and RTF
<a href="#">Print</a>	Opens the Print dialog where you can select a printer, set preferences, select a page range and number of copies and then print.
<a href="#">Refresh Usage</a>	Updates all the nodes in the Usage Report.

Property View	Description
Impact Analysis	
Filter Designation	<p>Indicates whether a <a href="#">Filter</a> has been set for the Impact Analysis Report.</p> <p>Two icons are displayed to the left of the Filter Designation indicator:</p> <p> Click  to display the impact analysis information in a tree format.</p> <p> Click  to display the impact analysis information in a table format.</p>
<a href="#">Create Impact Analysis Diagram</a>	Once you create a link you can create a diagram that is a graphical representation of that link.
<a href="#">Filter</a>	Opens the Impact Analysis Filter dialog
Export	You can export and save the Impact Analysis report in the following file formats: CSV, HTML, PDF, and RTF.
Print	Opens the Print dialog where you can select a printer, set preferences, select a page range and number of copies and then print.
Expand All	Expands all the nodes in the tree.
Collapse All	Collapses all the nodes in the tree.
Refresh	Updates all the nodes in the Impact Analysis Report.
Appearance	
<a href="#">Font and Color Options</a>	Use these commands to change fonts and element colors. Note that the element line and fill command is unavailable for the Business Rule element.
<a href="#">Rendering</a>	<p>There are two commands available:</p> <p>Shadowed: Turn the "3-D" shadowing on or off for the drawing shape.</p> <p>Transparent: Turn the "fill" off so drawing shape is transparent. Only the border is displayed.</p> <p>Note: You can set <a href="#">Rendering</a> default preferences.</p>
<a href="#">Horizontal Alignment</a>	Use these commands to set the justification for text labels in an element.
<a href="#">Vertical Alignment</a>	Use these commands to set the alignment (top, centered or bottom) of a text label within an element.
Diagram Display Options	Select this option to show the element label.
Line Display Options	<p>Line Width: Select the width of the border from the drop-down list. You can select from 1 to 5 pixels.</p> <p>Line Style: Select the line style from a drop-down list.</p>









Property View	Description
Apply to Diagram	Applies the formatting changes to all existing shapes on the active diagram.
Restore Defaults	Restores the default settings for all changes made in the Appearance tab.
Set as Default	All formatting changes made in the Appearance tab become the default settings for new shapes placed in the Diagram View.

## Text Label

The table below describes the Property View fields available for the Text Label:

Property View	Description
General	
Name	Label that appears for an element both in the Model View tree and in the diagram. You can edit this label.
Text	Contains the text for the label.
Type:	Displays the type of shape, for example, text label.
Description	
	<p>A text box where you can enter information describing or defining the project. Right-click text to open a shortcut menu. You can cut, copy, paste, and delete selected text within the Description text box. You can paste plain text from external applications.</p> <p>You can undo any action and you can select all text by pressing Ctrl+A.</p> <p>The following formatting options are available for the text: Bold, Italics, Underscore, and Strikethrough. You can also change the font color as well as the background color.</p>
Notes	
	<p>A text box where you can annotate the element with additional information. Right-click text to open a shortcut menu. You can cut, copy, paste, and delete selected text within the Notes text box. You can paste plain text from external applications.</p> <p>You can undo any action and you can select all text by pressing Ctrl+A.</p> <p>The following formatting options are available for the text: Bold, Italics, Underscore, and Strikethrough. You can also change the font color as well as the background color.</p>
Links	
Add Link	Opens the <a href="#">Create Link</a> wizard. This wizard allows you to create conceptual or usage links between elements.



Property View	Description
Edit Link	Opens the property view for the selected link.
Delete Link	Deletes the selected link (either the link or the link target).
Show Selected Links on Active Diagram	Once you have created a link in the Diagram View, click this icon to display the links for the selected object in the diagram.
Expand All	Expands all the nodes in the tree.
Collapse All	Collapses all the nodes in the tree.
Refresh Links	Updates all the nodes in the Link Report.
Usage (CRUD)	
Usage	<p>The header displays the name of the linked element and the status of the filter (on or off).</p> <p>Receivers: Displays a list of the elements with usages (receivers). You can select multiple receivers in this list and delete all the receivers that are selected.</p> <p>Usage: Displays the usage setting (C, R, U, D). You can change the Usage attributes in this column and this change is reflected in the diagram. For example, you can change a C (Create) type to a U (Update) type.</p> <p>Usage Description: Displays the information entered in the Description text field for the target object of the usage. For example, if a usage was drawn between a task and a Data Store object, the description of the Data Store object is displayed.</p> <p>If there are no links or all the links have been filtered out, you are given the information that "No usages have been defined for this element" in the Receivers column.</p>
<a href="#">Add Usage</a>	Opens the Create Usage wizard where you can create a new usage.
<a href="#">Edit Usage</a>	When you select a Receiver in the table, the edit option becomes available. Click this to open the Usage edit tab where you can edit the name of the usage. The default name is "Usage". You can also change the usage settings (Create, Read, Update, and Delete). 
Delete	When you select a Receiver in the table, the delete option becomes available. This action removes the selected receiver from the usage. 
Show Selected Usages	When you select a Receiver in the table, the Show Selected Usages option (  ) becomes available. Click this icon to display the usage for the selected receiver in the diagram, including the usage settings.
Filter Receiver Types	Opens the Usage Report Filter dialog where you can select the types of objects you want included in the Usage Report.
<a href="#">Export Usage Report</a>	You can export the Usage (CRUD) reports in the following formats: CSV, HTML, PDF, and RTF
<a href="#">Print</a>	Opens the Print dialog where you can select a printer, set preferences, select a page range and number of copies and then print.
Refresh Usage	Updates all the nodes in the Usage Report.





Property View	Description
Impact Analysis	
Filter Designation	<p>Indicates whether a <a href="#">Filter</a> has been set for the Impact Analysis Report.</p> <p>Two icons are displayed to the left of the Filter Designation indicator:</p> <p> Click  to display the impact analysis information in a tree format.</p> <p> Click  to display the impact analysis information in a table format.</p>
<a href="#">Create Impact Analysis Diagram</a>	Once you create a link you can create a diagram that is a graphical representation of that link.
<a href="#">Filter</a>	Opens the Impact Analysis Filter dialog
Export	You can export and save the Impact Analysis report in the following file formats: CSV, HTML, PDF, and RTF.
Print	Opens the Print dialog where you can select a printer, set preferences, select a page range and number of copies and then print.
Expand All	Expands all the nodes in the tree.
Collapse All	Collapses all the nodes in the tree.
Refresh	Updates all the nodes in the Impact Analysis Report.
Appearance	
<a href="#">Font and Color Options</a>	Use these commands to change fonts and element colors. Note that the element line and fill command is unavailable for the Business Rule element.
<a href="#">Horizontal Alignment</a>	Use these commands to set the justification for text labels in an element.
<a href="#">Vertical Alignment</a>	Use these commands to set the alignment (top, centered or bottom) of a text label within an element.
Diagram Display Options	Select this option to show the element label.
Line Display Options	Select the width of the border from the drop-down list. You can select from 1 to 5 pixels.
Apply to Diagram	Applies the formatting changes to all existing text labels on the active diagram.
Restore Defaults	Restores the default settings for all changes made in the Appearance tab.
Set as Default	All formatting changes made in the Appearance tab become the default settings for new text labels placed in the Diagram View.

## Line

The table below describes the Property View fields available for the Line drawing shapes:

Property View	Description
General	
Name	Label that appears for an element both in the Model View tree and in the diagram. You can edit this label.
Type:	Displays the type of shape, i.e., Octagon.
Description	
	<p>A text box where you can enter information describing or defining the project. Right-click text to open a shortcut menu. You can cut, copy, paste, and delete selected text within the Description text box. You can paste plain text from external applications.</p> <p>You can undo any action and you can select all text by pressing Ctrl+A.</p> <p>The following formatting options are available for the text: Bold, Italics, Underscore, and Strikethrough. You can also change the font color as well as the background color.</p>
Notes	
	<p>A text box where you can annotate the element with additional information. Right-click text to open a shortcut menu. You can cut, copy, paste, and delete selected text within the Notes text box. You can paste plain text from external applications.</p> <p>You can undo any action and you can select all text by pressing Ctrl+A.</p> <p>The following formatting options are available for the text: Bold, Italics, Underscore, and Strikethrough. You can also change the font color as well as the background color.</p>
Links	
Add Link	Opens the <a href="#">Create Link</a> wizard. This wizard allows you to create conceptual or usage links between elements.
Edit Link	Opens the property view for the selected link.
Delete Link	Deletes the selected link (either the link or the link target).
Show Selected Links on Active Diagram	Once you have created a link in the Diagram View, click this icon to display the links for the selected object in the diagram.
Expand All	Expands all the nodes in the tree.
Collapse All	Collapses all the nodes in the tree.
Refresh Links	Updates all the nodes in the Link Report.



Property View	Description
Usage (CRUD)	
Usage	<p>The header displays the name of the linked element and the status of the filter (on or off).</p> <p>Receivers: Displays a list of the elements with usages (receivers). You can select multiple receivers in this list and delete all the receivers that are selected.</p> <p>Usage: Displays the usage setting (C, R, U, D). You can change the Usage attributes in this column and this change is reflected in the diagram. For example, you can change a C (Create) type to a U (Update) type.</p> <p>Usage Description: Displays the information entered in the Description text field for the target object of the usage. For example, if a usage was drawn between a task and a Data Store object, the description of the Data Store object is displayed.</p> <p>If there are no links or all the links have been filtered out, you are given the information that "No usages have been defined for this element" in the Receivers column.</p>
<a href="#">Add Usage</a>	Opens the Create Usage wizard where you can create a new usage.
<a href="#">Edit Usage</a>	<p>When you select a Receiver in the table, the edit option becomes available. Click this to open the Usage edit tab where you can edit the name of the usage. The default name is "Usage". You can also change the usage settings (Create, Read, Update, and Delete).</p> 
Delete	<p>When you select a Receiver in the table, the delete option becomes available. This action removes the selected receiver from the usage.</p> 
Show Selected Usages	<p>When you select a Receiver in the table, the Show Selected Usages option () becomes available. Click this icon to display the usage for the selected receiver in the diagram, including the usage settings.</p>
Filter Receiver Types	Opens the Usage Report Filter dialog where you can select the types of objects you want included in the Usage Report.
<a href="#">Export Usage Report</a>	You can export the Usage (CRUD) reports in the following formats: CSV, HTML, PDF, and RTF
<a href="#">Print</a>	Opens the Print dialog where you can select a printer, set preferences, select a page range and number of copies and then print.
Refresh Usage	Updates all the nodes in the Usage Report.

Property View	Description
Impact Analysis	
Filter Designation	<p>Indicates whether a <a href="#">Filter</a> has been set for the Impact Analysis Report.</p> <p>Two icons are displayed to the left of the Filter Designation indicator:</p> <p> Click  to display the impact analysis information in a tree format.</p> <p> Click  to display the impact analysis information in a table format.</p>
<a href="#">Create Impact Analysis Diagram</a>	Once you create a link you can create a diagram that is a graphical representation of that link.
<a href="#">Filter</a>	Opens the Impact Analysis Filter dialog
Export	You can export and save the Impact Analysis report in the following file formats: CSV, HTML, PDF, and RTF.
Print	Opens the Print dialog where you can select a printer, set preferences, select a page range and number of copies and then print.
Expand All	Expands all the nodes in the tree.
Collapse All	Collapses all the nodes in the tree.
Refresh	Updates all the nodes in the Impact Analysis Report.
Appearance	
<a href="#">Font and Color Options</a>	Use these commands to change fonts and element colors. Note that the element line and fill command is unavailable for the Business Rule element.
Diagram Display Options	Select this option to show the element label and any connections.
Line Display Options	<p>Select the width of the border from the drop-down list. You can select from 1 to 5 pixels.</p> <p>You can also set the line style, source decorator, and target decorator.</p>
Apply to Diagram	Applies the formatting changes to all existing shapes on the active diagram.
Restore Defaults	Restores the default settings for all changes made in the Appearance tab.
Set as Default	All formatting changes made in the Appearance tab become the default settings for new shapes placed in the Diagram View.





## Annotation

The table below describes the Property View fields available for the Annotation drawing shapes:

Property View	Description
General	
Name	Label that appears for an element both in the Model View tree and in the diagram. You can edit this label.
Type:	Displays the type of shape, i.e., Octagon.
Description	
	<p>A text box where you can enter information describing or defining the project. Right-click text to open a shortcut menu. You can cut, copy, paste, and delete selected text within the Description text box. You can paste plain text from external applications.</p> <p>You can undo any action and you can select all text by pressing Ctrl+A.</p> <p>The following formatting options are available for the text: Bold, Italics, Underscore, and Strikethrough. You can also change the font color as well as the background color.</p>
Notes	
	<p>A text box where you can annotate the element with additional information. Right-click text to open a shortcut menu. You can cut, copy, paste, and delete selected text within the Notes text box. You can paste plain text from external applications.</p> <p>You can undo any action and you can select all text by pressing Ctrl+A.</p> <p>The following formatting options are available for the text: Bold, Italics, Underscore, and Strikethrough. You can also change the font color as well as the background color.</p>
Links	
Add Link	Opens the <a href="#">Create Link</a> wizard. This wizard allows you to create conceptual or usage links between elements.
Edit Link	Opens the property view for the selected link.
Delete Link	Deletes the selected link (either the link or the link target).
Show Selected Links on Active Diagram	Once you have created a link in the Diagram View, click this icon to display the links for the selected object in the diagram.
Expand All	Expands all the nodes in the tree.
Collapse All	Collapses all the nodes in the tree.
Refresh Links	Updates all the nodes in the Link Report.

Property View	Description
Usage (CRUD)	
Usage	<p>The header displays the name of the linked element and the status of the filter (on or off).</p> <p>Receivers: Displays a list of the elements with usages (receivers). You can select multiple receivers in this list and delete all the receivers that are selected.</p> <p>Usage: Displays the usage setting (C, R, U, D). You can change the Usage attributes in this column and this change is reflected in the diagram. For example, you can change a C (Create) type to a U (Update) type.</p> <p>Usage Description: Displays the information entered in the Description text field for the target object of the usage. For example, if a usage was drawn between a task and a Data Store object, the description of the Data Store object is displayed.</p> <p>If there are no links or all the links have been filtered out, you are given the information that "No usages have been defined for this element" in the Receivers column.</p>
<a href="#">Add Usage</a>	Opens the Create Usage wizard where you can create a new usage.
<a href="#">Edit Usage</a>	<p>When you select a Receiver in the table, the edit option becomes available. Click this to open the Usage edit tab where you can edit the name of the usage. The default name is "Usage". You can also change the usage settings (Create, Read, Update, and Delete).</p> 
Delete	<p>When you select a Receiver in the table, the delete option becomes available. This action removes the selected receiver from the usage.</p> 
Show Selected Usages	<p>When you select a Receiver in the table, the Show Selected Usages option () becomes available. Click this icon to display the usage for the selected receiver in the diagram, including the usage settings.</p>
Filter Receiver Types	Opens the Usage Report Filter dialog where you can select the types of objects you want included in the Usage Report.
<a href="#">Export Usage Report</a>	You can export the Usage (CRUD) reports in the following formats: CSV, HTML, PDF, and RTF
<a href="#">Print</a>	Opens the Print dialog where you can select a printer, set preferences, select a page range and number of copies and then print.
Refresh Usage	Updates all the nodes in the Usage Report.



Property View	Description
Impact Analysis	
Filter Designation	<p>Indicates whether a <a href="#">Filter</a> has been set for the Impact Analysis Report.</p> <p>Two icons are displayed to the left of the Filter Designation indicator:</p> <p> Click  to display the impact analysis information in a tree format.</p> <p> Click  to display the impact analysis information in a table format.</p>
<a href="#">Create Impact Analysis Diagram</a>	Once you create a link you can create a diagram that is a graphical representation of that link.
<a href="#">Filter</a>	Opens the Impact Analysis Filter dialog
Export	You can export and save the Impact Analysis report in the following file formats: CSV, HTML, PDF, and RTF.
Print	Opens the Print dialog where you can select a printer, set preferences, select a page range and number of copies and then print.
Expand All	Expands all the nodes in the tree.
Collapse All	Collapses all the nodes in the tree.
Refresh	Updates all the nodes in the Impact Analysis Report.
Appearance	
<a href="#">Font and Color Options</a>	Use these commands to change fonts and element colors. Note that the element line and fill command is unavailable for the Business Rule element.
<a href="#">Horizontal Alignment</a>	Use these commands to set the justification for text labels in an element.
Diagram Display Options	Select this option to show the element label.
Line Display Options	Select the width of the border from the drop-down list. You can select from 1 to 5 pixels.
Apply to Diagram	Applies the formatting changes to all existing shapes on the active diagram.
Restore Defaults	Restores the default settings for all changes made in the Appearance tab.
Set as Default	All formatting changes made in the Appearance tab become the default settings for new shapes placed in the Diagram View.



# Glossary

**Annotation:** An Annotation is a piece of information attached to a certain region of a text document. Annotations are attached to documents via their annotation model and may be displayed in text editors and views.

**API:** Abbreviation of *application program interface*, a set of routines, protocols, and tools for building software applications. A good API makes it easier to develop a program by providing all the building blocks. A programmer puts the blocks together.

Most operating environments, such as MS-Windows, provide an API so that programmers can write applications consistent with the operating environment. Although APIs are designed for programmers, they are ultimately good for users because they guarantee that all programs using a common API will have similar interfaces. This makes it easier for users to learn new programs.

**Assign Time:** An Assignment may have an AssignTime setting. If the Object is an activity (Task, Sub-Process, or Process), then the Assignment must have an AssignTime. A value of Start means that the assignment shall occur at the start of the activity. This can be used to assign the higher-level (global) Properties of the Process to the (local) Properties of the activity as an input to the activity. A value of End means that the assignment shall occur at the end of the activity. This can be used to assign the (local) Properties of the activity to the higher-level (global) Properties of the Process as an output to the activity.

**Association - Conceptual Modeling:** An Association shows the relationship between two things representing a loose coupling.

**Association - Business Process Modeling:** An Association is used to associate information and artifacts with events and activities.

**Black Box Pool:** A Black Box Pool hides all activity detailed within the Pool.

**Business Attribute:** Used in Conceptual Modeling. This is a property of a business entity. An example would be "Customer Name".

**Business Entity:** Used in Conceptual Modeling. A "thing" of the business/organization containing other business entities or elements. An example of an entity would be "Customer".

**Business Process Diagram (BPD):** A Business Process Diagram (BPD) uses a flowcharting technique which is tailored for creating graphical models of business process operations. A Business Process Model is a network of graphical elements, which track the flow of activities and their order of performance.

**Business Process Management System (BPMS):** Refers to activities performed by businesses to optimize and adapt their processes.

**Business Process Modeling Language (BPML):** The Business Process Modeling Language (BPML) is a meta-language for the modeling of business processes, just as XML is a meta-language for the modeling of business data. BPML provides an abstracted execution model for collaborative and transactional business processes based on the concept of a transactional finite-state machine.

**Business Process Modeling Notation (BPMN):** A Business Process Diagram is made up of a set of graphical elements. These elements enable the development of simple diagrams.

**Business Process Query Language (BPQL):** The Business Process Query Language (BPQL) is a management interface to a business process management infrastructure that includes a process execution facility (Process Server) and a process deployment facility (Process Repository).

The BPQL interface to a Process Server enables business analysts to query the state and control the execution of process instances managed by the Process Server. This interface is based on the Simple Object Access Protocol (SOAP).

**Business Rules System:** An automated system where the “rules” are separated and shared across data stores, user interfaces and applications. A rule is a formal expression of knowledge or preference which steers behavior in a desired direction.

**Business Unit:** Part of an organization treated for any purpose as a separate entity within the parent organization. Examples include a department or distribution center.

**Compensation:** Compensation is when activities are invoked that undo an undesirable outcome.

**Complex Decision:** This expression determines which output flow is taken from multiple Sequence Flow names.

**Complex Merge:** You specify a complex flow condition referencing incoming Sequence Flow names or process data coming into a gateway. This expression determines when the task starts.

**Conceptual Modeling:** High level models used to explain entities related to the business / organization. This modeling maps to the higher level Subject Area model and to the lower level Logical Data model.

**Data-based XOR decision:** A data-based XOR decision is the most common XOR gateway used. A data token traverses the Process Flow and arrives at the XOR gateway. The path it chooses is based on condition expressions for each gate. It is restricted to only one flow.

**Data Objects:** Data objects provide information about how documents, data, and other objects are used and updated in a Process. They represent data so are defined by a combination of entities or classes.

**Design:** The part of software development process whose primary purpose is to decide how the system will be implemented. During design, strategic and tactical decisions are made to meet the required functional and quality requirements of a system.

**Design Area:** The area in the Diagram window where you create your designs.

**Diagram:** A graphical presentation of a collection of model elements often rendered as connected graph of arcs and vertices. UML supports the following diagrams: class diagram, object diagram, use case diagram, sequence diagram, collaboration diagram, state diagram, activity diagram, component diagram, and deployment diagram.

**End Event:** Ends a process flow. Additional result types are available on the palette, from the shortcut menu, and in the property view.

**End Kill Event:** The process has encountered a fatal error and all activities in the process should be immediately ended. The process is ended without compensation or event handling.

**Enumeration:** A list of named values used as the range of a particular attribute type. For example, RGBColor = {red, green, blue}. Boolean is a predefined enumeration with values from the set {false, true}.

**Event:** Happens during the course of a process flow.

**Exception:** Error messages generated.

**Execution:** The running of a dynamic model.

**Exclusive Merge (XOR):** The most common gateways used. A data token traverses the Process Flow arriving at the gateway. It can only go out on one flow. This control type is represented by either a blank diamond shape or a diamond with an "x" in the middle.

**Expression:** Enter the expression that defines the relationship between one InputSet and one OutputSet. That is, if the activity is instantiated with a specified InputSet, then the output of the activity MUST produce the specified OutputSet. Zero or more IORules may be entered.

**Final Node:** Final node that stops all flows in an activity. An activity may have more than one final node.

**Flow Final:** Final node that terminates a flow. A flow final destroys all tokens that arrive at it.

**Gateways:** The gateway symbol models decisions, merges, forks and joins in the process flow. A gateway is a question that is asked at a point in the process flow with alternative answers.

**Generated Name:** The generated name is a code-friendly name that you may not want to see in the Model View tree or the diagram. For example, you may want to display a multibyte name (name), and have a code friendly single byte generated name. Or you may want a user-friendly name (e.g My First Task), but a generated name like "MY\_FIRST\_TASK". You can edit this name.

**Grid Editor:** This is a table-like editor which is an alternative to the Model View. Content in the Grid Editor can be printed or exported as a report.

**IDEF:** Integrated Computer-aided Manufacturing (ICAM) Definition. 16 different IDEF methods. Key methods are listed below. The three core models are: IDEF0, IDEF1X, and IDEF3.

- IDEF0 -Business Process Diagram (Integration Definition Language 0) (functional modeling)
- IDEF1X - Data Modeling
- IDEF2 - Simulation
- IDEF3 - Workflow or Process Diagramming
- IDEF4 - Object oriented Design
- IDEF8 - User-interface Design
- IDEF12 - Organization Modeling

**Impact Analysis Diagram:** Opens a new diagram which graphically displays all links associated with the object. Links connect to objects that can't be visualized on a diagram are not included.

**Impact Analysis Report:** Opens the Impact Analysis tab in the property view, which shows the interrelationships between elements in the Model View tree.

**Inclusive OR Decision:** One or more of the outgoing Sequence Flows may be taken. A default flow must be specified at this point, there cannot be zero output flows.

**Inclusive OR Merge:** A process flow continues when it receives the first input signal from the input Sequence Flows. If other signals arrive after that, they are not used.

**Inheritance:** Used in Conceptual modeling. It is the relationship between two things where one is created from the other.

**Interaction:** Used in Conceptual modeling. It is a relationship between two things representing an action, process, or transaction.

**Intermediate Event:** Happens during the course of a process event. Additional trigger types are available on the palette, from the shortcut menu, and in the property view.

**Iterative:** In the context of the software development lifecycle, a process that involves managing a stream of executable releases.

**Lane:** A lane is a container or package. They are children of pools. Lanes can represent different parts of an organization.

**Local History:** Local history of a file is maintained when you create or modify a file. Each time you edit and save a file, a copy of it is saved. This allows you to compare your current file state to a previous state, or replace the file with a previous state. Each state in the local history is identified by the date and time the file was saved.

**Location:** The placement of a component on a node.

**Loop Type:** LoopType is an attribute and is by default None, but may be set to Standard or Multi Instance. If so, the Loop marker shall be placed at the bottom center of the activity shape.

**Message Flow:** Helps you order the processes between organizations or departments (i.e., between pools).

**Message Numbers:** Message numbers illustrate the ordering of messages on Sequence and Collaboration diagrams.

**Metaclass:** A class whose instances are classes. Metaclasses are typically used to construct metamodels.

**Meta-metamodel:** A model that defines the language for expressing a metamodel. The relationship between a meta-metamodel and a metamodel is analogous to the relationship between a metamodel and model.

**Metamodel:** A model that defines the language for expressing a model.

**Metaobject:** A generic term for all metaentities in a metamodeling language. For example, metatypes, metaclasses, metaattributes, and metaassociations.

**Model:** A Model is a specific collection of diagrams and elements related to the Business Process Modeling Notation. For example, a banking industry BPMN model would contain those elements associated with the banking business process. The Model contains Business Process Diagrams which are graphical representations of all the elements of the process.

**Model Business Events:** In business process modeling, events are modeled that happen in the business and how they affect process flows. An event can kick off a process flow, it can happen during a process flow, or it can end a process flow.

**Model Elaboration:** The process of generating a repository type from a published model. Includes the generation of interfaces and implementations which allows repositories to be instantiated and populated based on, and in compliance with, the model elaborated.

**Model Element:** An element that is an abstraction drawn from the system being modeled.

**Model Library:** A stereotyped package that contains model elements that are intended to be reused by other packages. A model library differs from a profile in that a model library does not extend the metamodel using stereotypes and tagged definitions. A model library is analogous to a class library in some programming languages.

**Multi-Drop State:** This is the default setting in ER/Studio BA that allows you to drop multiple elements in the diagram design area.

**Name:** A string used to identify a model element.

**Namespace:** A part of the model in which the names may be defined and use. Within a namespace, each name has a unique meaning.

**Nature:** Project natures allow a plug-in to tag a project as a specific kind of project. For example, the Java development tools (JDT) use a "Java nature" to add Java-specific behavior to projects. Project natures are defined by plug-ins, and are typically added or removed per-project when the user performs some action defined by the plug-in.

**Object:** An entity with a well-defined boundary and identity that encapsulates state and behavior. State is represented by attributes and relationships, behavior is represented by operations, methods, and state machines. An object is an instance of a class.

**Object Constraint Language:** A formal language used to express side effect-free constraints.

**Objects and Instances:** Object is an abstraction representing some component of a system, and can be used to represent the components of any system. When the actual component occurs, it is an instance of that object. Often, the object is said to have been instantiated, or created in a system. In software systems, objects represent run-time instances of some type of processing, and the values used to accomplish this processing. In this documentation, object is used in the broadest sense -- it is not restricted to objects as defined in object-oriented design theory.

**Palette:** Palettes contain icons representing all the symbols you need for a particular methodology model, such as the Class Diagram notation. When laying out your design, you use these symbols to represent different symbols and their relationships with each other. Every time you open a new diagram, the palette with the diagram's associated symbols appears in the left side of the Diagram window.

**Parallel Forking (AND):** All sequence flows out of this gateway are taken.

**Parallel Joining (AND):** This gate must receive input signals from all input Sequence Flows. The process flow does not continue until it receives all signals.

**Parameter:** The specification of a variable that can be changed, passed, or returned. A parameter may include a name, type, and direction. Parameters are used for operations, messages, and events.

**Parameterized Element:** The descriptor for a class with one or more unbound parameters.

**Parent:** In a generalization relationship, the generalization of another element, the child.

**Participant:** You must define the Participant for a Pool. The Participant can be either a Role or an Entity. This defines the role that a particular Entity or Role the Pool will play in a Diagram that includes collaboration.

**Participate:** The connection of a model element to a relationship or to a relationship. For example, a class participates in an association, an actor participates in an use case.

**Partition:** 1. Activity graphs: A portion of an activity graphs that organizes the responsibilities for actions. 2. Architecture: A set of related classifiers or packages at the same level of abstraction or across layers in a layered architecture. A partition represents a vertical slice through an architecture, whereas a layer represents a horizontal slice.

**Path Variable:** Path variables specify locations on the file system. The location of linked resources may be specified relative to these path variables. They allow you to avoid references to a fixed location on your file system. By using a path variable, you can share projects containing linked resources with team members without requiring the exact same directory structure as on your file system.

**Pinning:** One element can be selected and pinned, allowing you to select other elements will still being able to document the pinned element.

**Pools:** Pools denote who is performing a process. A pool can be partitioned into [lanes](#). A pool represents an organization and a lane is a department within that organization, functions, application or systems.

**Presentation Element:** Elements displayed in the Model View tree are represented by an icon only with no associated meta-data. If an element is a presentation element, it is indicated by a small white box with a directional arrow attached to the element.

**Process:** A Process is a collection of flow objects that reside in a pool connected by flows that is executed in a sequence (usually depicted on a diagram). In ER/Studio BA, all processes are contained by a pool. A pool contains only one process, but you can have multiple pools in a diagram which can then collaborate via message links.

In the Business Process Modeling Notation Specification, all Business Process Diagrams must contain at least one pool. In ER/Studio BA, when you create a new diagram, a pool and lane with an invisible boundary are created as well. In ER/Studio BA, when you place an object in the diagram, that object is placed in the lane.

**Project:** A project is used to create a collection of user-created data models or subprojects. Data sources and reference objects also exist as their own projects within the workspace. A Project is a collection of items including models, model elements, documents, business rules, etc. For example, a "Human Resources" project might contain a business process model describing the main functions of the Human Resources department, and a data model describing the data structures used by these processes, and business rules describing prescribed behavior of the organization. You can also create nested projects where a project is a parent of another project.

**Qualifier:** An association attribute whose values partition the set of objects related to an object across an association.

**RCP:** Rich Client Platform. A platform for building client applications with rich functionality.

**RDBMS:** Short for *relational database management system* and pronounced as separate letters, a type of database management system (DBMS) that stores data in the form of related tables. Relational databases are powerful because they require few assumptions about how data is related or how it will be extracted from the database. As a result, the same database can be viewed in many different ways.

An important feature of relational systems is that a single database can be spread across several tables. This differs from flat-file databases, in which each database is self-contained in a single table.

Almost all full-scale database systems are RDBMS's. Small database systems, however, use other designs that provide less flexibility in posing queries.

**Receive Task:** A simple Task that is designed to wait for a message to arrive from an external participant. Once the message has been received, the Task is completed.



**Run Time:** The period of time during which a computer program executes.

**Scenario:** A specific sequence of actions that illustrates behaviors. A scenario may be used to illustrate an interaction or the execution of a use case instance.

**Script Task:** A Script Task is executed by a business process engine. The modeler or implementer defines a script in a language that the engine can interpret. When the Task is ready to start, the engine executes the script. When the script is completed, the Task is also completed.

**Semantic Symbols:** When designing interaction diagrams before creating the class diagrams if a symbol with no class assigned is assigned to a class that does not exist, ER/Studio BA asks if you want it to create a corresponding class. If you instruct ER/Studio BA to create the class, ER/Studio BA creates a semantic (non-displayed) class and places it in the ER/Studio BA System Tree as well as the Navigator window. ER/Studio BA populates the class with defined attributes and operations corresponding to the incoming messages and creates all of the internal linkage necessary to support subsequent consistency and diagram synchronization. You can drag these classes (including their associated attributes and operations) onto any class diagram.

**Semantic Variation Point:** A point of variation in the semantics of a metamodel. It provides an intentional degree of freedom for the interpretation of the metamodel semantics.

**Send Message:** The passing of a stimulus from a sender instance to a receiver instance.

**Send Task:** A simple Task that is designed to send a message to an external participant. Once the message has been sent, the Task is completed.

**Sequence Flow:** This is used to show the sequence of processes in an organization or department. If you have pools or lanes in your diagram, you can use Sequence Flow lines to connect events, processes and gateways placed within the pools or lanes.

**Service Task:** A Service Task is a Task that provides some sort of service, which could be a Web service or an automated application. This is the default setting.

**Start Message:** A start message comes from a participant and triggers the start of the process. Or it can continue the process in the case of an intermediate event.

**Start Event:** Starts a [process](#) flow

**Start Timer:** A specific time-date or a specific cycle (e.g., every Friday at 10:00 a.m.) is set that triggers the start of the Process.

**Start Link:** A mechanism for connecting the end of one Process to the start (or trigger) of another.

**Start Message:** A message arrives from a participant and triggers the start of the Process.

**Start Rule:** This type of event is triggered when the conditions for a rule become true.

**SWT:** Standard Widget Toolkit (SWT) is a widget toolkit for Java designed to provide efficient, portable access to the user-interface facilities of the operating systems on which it is implemented.

**Subject Area Modeling:** Extremely high-level model of “things” related in the business/organization. This modeling maps to the lower-level Conceptual Model.

**Subject Area:** Used in Conceptual modeling. Element is a container for other subject areas or business entities.

**Sub-process:** A process drawn on a 'child' diagram is called a sub-process.

**Swim Lanes:** You can group primary modeling elements by using swimlanes which consist of pools and lanes. A Pool represents a participant in a process. It also acts as a graphical container for partitioning a set of activities from other Pools, usually in the context of Business-to-Business (B2B) situations. A Lane is a subpartition within a Pool and extends the entire length of the Pool. Lanes are used to organize and categorize activities.

**Symbol:** In this documentation, symbol refers to a model element.

**Systems:** A system is a set or arrangement of things that form a whole. A system also embodies a set of rules and guidelines that specify a given plan or method of doing something. In accordance with this definition, a software system is comprised of a collection of software programs that accomplish a computer-based task. Some examples of these software systems are an Automated Teller System, an Inventory System, and a Flight Reservation System.

**System:** A top-level subsystem in a model.

**Task:** This is an activity that is performed within a business process.

**Time:** A value representing an absolute or relative moment.

**Time Event:** An event that denotes the time elapsed since the current state was entered.

**Time Expression:** An expression that resolves to an absolute or relative value of time.

**Timing Constraint:** A semantic statement about the relative or absolute value of time or duration.

**Timing Mark:** A denotation for the time at which an event occurs.

**Trigger:** Events (Start, Intermediate and End) can have triggers that indicate the purpose of the event. Triggers include: Cancel, Compensate, Error, Message, Timer, Rule, Link, Multiple, or Terminate.

**Type Expression:** An expression that evaluates to a reference to one or more types.

**UML:** Unified Modeling Language, a language for visualizing, specifying, constructing, and documenting the artifacts of a software-intensive system.

**Usage (CRUD) Reports:** Usage (CRUD) Reports are designed to show how a process affects given data objects, specifically whether objects are Created, Read, Updated, or Deleted.

**User Task:** A typical "workflow" task where a human performer performs the Task with the assistance of a software application and is scheduled through a task list manager of some sort.

**Value:** An element of a type domain.

**View:** A projection of a model, which is seen from a given perspective or vantage point and omits entities that are not relevant to this perspective.

**View Element:** A view element is a textual and/or graphical projection of a collection of model elements.

**View Projection:** A projection of model elements onto view elements. A view projection provides a location and a style for each view element.

**Visibility:** An enumeration whose value (public, protected, or private) denotes how the model element to which it refers may be seen outside its enclosing namespace.



**Visitor Behavioral Pattern:** Represent an operation to be performed on the elements of an object structure. Visitor lets you define a new operation without changing the classes of the elements on which it operates.

**Workspace:** A workspace is a unit of storage used for any collection of data modeling projects, reference objects, and data source projects. In ER/Studio BA you can only open and work with one workspace at a time, but you can collect any number of projects in a single workspace.

**XOR Gateway:** XOR gates can model either data-based or event-based decisions.

**XSLT:** Short for *Extensible Style Language Transformation*, the language used in XSL style sheets to transform XML documents into other XML documents.

An XSL processor reads the XML document and follows the instructions in the XSL style sheet, then it outputs a new XML document or XML-document fragment.

This is extremely useful in e-commerce, where the same data need to be converted into different representations of XML. Not all companies use the exact same programs, applications and computer systems.

XSLT Recommendation was written and developed by the XSL Working Group and became ratified by the W3C on November 16, 1999.